

**New York City Economic Development Corporation  
 Manhattan Cruise Terminal Master Plan  
 Navigation Safety Risk Assessment**

2025-12-19	0	Issued for Use	T. Chen	S. Robins	J. Nelson	J. Ting
2025-12-03	C	Client Review	T. Chen	S. Robins	J. Nelson	-
2025-11-06	B	Client Review	T. Chen	S. Robins	J. Nelson	-
2025-10-28	A	Client Review	T. Chen	S. Robins	J. Nelson	-
<b>Date</b>	<b>Rev.</b>	<b>Status</b>	<b>Prepared By</b>	<b>Checked By</b>	<b>Approved By</b>	<b>Approved By</b>
<b>HATCH</b>						<b>Client</b>

## Table of Contents

<b>Glossary of Terms</b> .....	<b>vii</b>
<b>1. Study Background</b> .....	<b>1</b>
<b>2. Federally Authorized Channel and Study Area Description</b> .....	<b>8</b>
2.1 Hudson River Channel.....	8
2.2 Summary of Current Regulations .....	11
2.2.1 The United States Army Corps of Engineers .....	11
2.2.2 The United States Coast Guard .....	11
2.3 Study Area .....	12
2.3.1 Metes-and-Bounds Methodology .....	12
2.3.2 Proposed Deauthorization Area .....	12
2.3.3 NSRA Study Area Definition .....	13
<b>3. Land Use and Zoning Analysis</b> .....	<b>13</b>
3.1 Overview .....	13
3.2 Summary of Surrounding Land Uses.....	14
3.3 Transportation.....	15
3.4 Summary of Surrounding Ownership.....	19
3.5 Previous Land Use Actions.....	20
3.6 Special Purpose Districts/Subdistricts .....	21
3.7 Proposed Development .....	22
3.8 Land Use Summary .....	22
<b>4. Baselineing of Existing Conditions</b> .....	<b>22</b>
4.1 Dredging and Bathymetry of the Hudson River Channel .....	22
4.2 Dredging at MCT.....	26
4.3 Physical Constraints .....	28
4.3.1 Summary of Existing Structures.....	28
4.3.2 Infrastructure Programs .....	31
4.3.3 Environmental Conditions .....	32
4.3.4 Recorded Wrecks and Obstructions .....	33
4.4 Aids to Navigation .....	34
4.4.1 Operational Aids to Navigation .....	34
4.4.2 Physical Aids to Navigation.....	34
4.4.3 Anchorages .....	37
<b>5. Stakeholder Consultation and Practical Mitigation Measures</b> .....	<b>39</b>
5.1 Pilots, Deep Draft, Tug and Barge.....	39
5.2 City Agencies .....	42
5.3 Ferry and Excursion Operators.....	44
5.4 Human Powered Boaters.....	45
5.5 Adjacent and Other Users .....	46
5.6 NSRA Outcomes Briefing .....	50

5.7	USACE and USCG .....	50
5.8	Practical Mitigation Measures .....	51
<b>6.</b>	<b>Impact of the Proposed Project .....</b>	<b>53</b>
6.1	Proposed Project Background .....	53
6.2	Existing Vessel Traffic .....	54
6.2.1	Introduction of AIS Data and Data Sources .....	54
6.2.2	Overview of Existing Vessel Traffic Patterns in Study Area .....	54
6.2.3	Existing Temporary Impacts to Navigation .....	57
6.2.4	Existing Traffic Characterization around the Manhattan Cruise Terminal .....	58
6.2.5	Cruise Ship Activity at MCT .....	65
6.3	Evaluation of the Proposed Project Footprint .....	69
6.3.1	Impacts to Passing Vessel Proximity at MCT .....	69
6.3.2	Impacts to Vessel Turning Circles and Maneuvering at MCT .....	72
6.3.3	Impacts to Vessels Frequenting Adjacent Piers to MCT .....	76
6.4	Vessel-Wake Interaction Assessment .....	78
6.4.1	USACE VWPT Software Introduction .....	78
6.4.2	Bathymetric Profile .....	79
6.4.3	Run Scenarios .....	80
6.4.4	Results .....	84
6.5	Analysis of Temporary Navigation Impacts .....	86
6.5.1	Temporary Impact Factors Considered for Construction Period .....	86
6.5.2	Project Construction Timeline and Associated Phase Impacts .....	87
6.5.3	Summary Table of Temporary Impacts to Navigation .....	94
<b>7.</b>	<b>Desktop Navigation Simulations.....</b>	<b>97</b>
7.1	2D Desktop Navigation Simulator Set-Up .....	97
7.2	Design Vessel Specifications .....	99
7.3	Desktop Navigation Simulation Run Conditions .....	100
7.4	Commentary on Bow First Versus Stern First Arrivals .....	104
7.5	Key Assumptions in Desktop Navigation Simulations .....	106
7.6	Desktop Navigation Simulation Outputs .....	107
7.7	Key Conclusions from Desktop Navigation Simulations .....	111
<b>8.</b>	<b>Risk Identification and Assessment and Recommendations .....</b>	<b>112</b>
8.1	Likelihood of Risks and Hazards .....	112
8.1.1	Historical Accident Frequency .....	113
8.1.2	Quantitative Navigational Risk Modelling .....	117
8.2	Future Considerations .....	139
8.2.1	Hydrodynamic Modelling and Sedimentation .....	139
8.2.2	Adjacent Vessels and Mooring Requirements .....	139
8.2.3	Planned Construction Works and Ferry Traffic .....	140
8.2.4	Operational Procedure Review .....	140
8.2.5	Environmental and Climate Resilience .....	140
8.2.6	Integration with AIS and Real-Time Monitoring .....	141

## List of Figures

Figure 1-1: Navigation Safety Risk Assessment Study Area, in the Context of the Upper New York Harbor with the Existing MCT Condition .....	3
Figure 1-2: Berth Layout at MCT in its Current Configuration .....	4
Figure 1-3: Channel Descriptions in Study Area .....	5
Figure 1-4: Proposed Configuration of Manhattan Cruise Terminal Redevelopment.....	6
Figure 1-5: Study Area with Proposed Project Footprint and Estimated Deauthorization Area .....	7
Figure 2-1: Channel and MCT Basin Dredge Depths .....	10
Figure 3-1: Land Uses in the Land Use Study Area Surrounding MCT.....	16
Figure 3-2: Public vs. Private Ownership of Land Use within Land Use Study Area.....	17
Figure 3-3: Ownership of Zones within Land Use Study Area .....	18
Figure 3-4: Transit and Bike Paths in the Land Use Study Area .....	19
Figure 4-1: Hudson River Channel 2025 USACE Condition Survey Indicating Channel Limits.....	24
Figure 4-2: Bathymetry Data in MCT Region of the Hudson River Channel as of April 2025 (Source: USACE).....	25
Figure 4-3: Spring 2024 Post-dredge Bathymetric Survey of MCT Basin .....	27
Figure 4-4: Electronic Navigation Chart of the Manhattan Cruise Terminal Area, Including the Study Area (Source: NOAA) .....	29
Figure 4-5: Aids to Navigation in the Study Area as of January 2, 2025, with the Full Restricted Area of the HRGS Project Depicted .....	36
Figure 4-6: Anchorage Areas in the General Vicinity of the Study Area.....	38
Figure 6-1: September 2024 Vessel Tracks by Type Inside the Study Area.....	55
Figure 6-2: 2023 Vessel Track Density for All Vessel Types in the Study Area .....	56
Figure 6-3: 2023 Passenger Vessel (non cruise) Track Density in Study Area.....	57
Figure 6-4: Gateway Development Commission Hudson Tunnel Project Cofferdam and Recommended Traffic Diversion Scheme (adapted from GDC (2025)).....	58
Figure 6-5: Transect Line at MCT to Perform Passing Vessel Analysis.....	59
Figure 6-6: 2023 Monthly Breakdown of Vessel Crossings by Type at MCT .....	60
Figure 6-7: 2023 Hourly Breakdown of Vessel Crossings by Type at MCT .....	61
Figure 6-8: 2023 Distribution of Vessel Dimensions at MCT for Length, Width, Draft (as reported in AIS).....	61
Figure 6-9: 2023 Distribution of Vessel Speeds Passing MCT.....	64
Figure 6-10: 2023 Cruise Ship Calls at MCT Broken Down by Month .....	65
Figure 6-11: 2023 Cruise Ship Calls at MCT Broken Down by Individual Vessels.....	66
Figure 6-12: 2023 Cruise Ship Tug Assists at MCT by Arrival (Source: Moran Towing) .....	67
Figure 6-13: 2023 Cruise Ship Tug Assists at MCT by Departure (Source: Moran Towing).....	67
Figure 6-14: 2023 Cruise Ship Call Tracks to and from MCT and Transects used for Speed Profile Analysis .....	68
Figure 6-15: 2023 Cruise Ship Speed Profiles to and from MCT .....	69
Figure 6-16: 2023 Existing Passing Vessel Distance Distribution to MCT .....	70
Figure 6-17: 2023 Proposed Future Passing Vessel Distance Distribution to MCT .....	71
Figure 6-18: 2023 Existing Passing Vessels At MCT Affected by Proposed Footprint .....	71
Figure 6-19: 2023 Cruise Ship Arrival Maneuver Tracks and Envelope at MCT.....	73
Figure 6-20: 2023 Cruise Ship Departure Maneuver Tracks and Envelope at MCT.....	74
Figure 6-21: Proposed Future Cruise Ship Arrival Envelopes at MCT with Minimally Required Offset for Safe Clearance Based on 2023 Data .....	75
Figure 6-22: Proposed Future Cruise Ship Departure Envelopes at MCT with Minimally Required Offset for Safe Clearance Based on 2023 Data .....	75
Figure 6-23: 2023 Vessel Traffic to/from Adjacent Piers Impacted by MCT Expansion.....	77
Figure 6-24: Existing Bathymetry Data Used for Vessel Wake Assessment at MCT.....	79
Figure 6-25: Bathymetric Cross-Section at MCT Used for Vessel Wake Analysis (existing red, proposed blue) .....	80
Figure 6-26: Vessel Wake Analysis Results for Existing and Proposed Conditions at MCT.....	85

Figure 6-27: Proposed Timeline Gantt Chart of MCT Expansion Operations .....	88
Figure 6-28: Temporary Navigation Impacts During Phase 1a.....	89
Figure 6-29: Temporary Navigation Impacts During Phase 1b.....	90
Figure 6-30: Temporary Navigation Impacts During Phase 2a.....	91
Figure 6-31: Temporary Navigation Impacts During Phases 3/4a.....	92
Figure 6-32: Temporary Navigation Impacts During Phase 4b.....	93
Figure 7-1: FORCE Technology 2D Desktop Simulator .....	98
Figure 7-2: Observed Conditions During 2023 and 2024 Arrivals and Departures of Cruise Ships at MCT .....	103
Figure 7-3: Assumed 2D Hydrodynamic Current Fields Applied in the Desktop Navigation Simulations	106
Figure 8-1: MISLE Database Accidents Within the Study Area from 2000 to 2024 .....	114
Figure 8-2: Breakdown of Groundings in the Study Area by Vessel Type .....	115
Figure 8-3: Breakdown of Allisions in the Study Area by Vessel Type.....	115
Figure 8-4: Breakdown of Collisions in the Study Area by Vessel Type.....	116
Figure 8-5: Breakdown by Vessel Type of Allisions at MCT Recorded in the MISLE Database Between 2000 and 2024 .....	117
Figure 8-6: SIREN Model Network Derived from Vessel Traffic.....	118
Figure 8-7: Supplemental Bathymetry Data Taken from NY Harbor Survey.....	120
Figure 8-8: Density of Background Traffic in Hudson River under Existing and Assumed Future Conditions Near MCT.....	123
Figure 8-9: Existing (left) and Proposed Future (right) Collision Risk Frequency Density Maps in Study Area.....	128
Figure 8-10: Existing (left) and Proposed Future (right) Grounding Frequency Density Maps in Study Area .....	131
Figure 8-11: Existing (left) and Proposed Future (right) Allision Frequency Density Maps in Study Area	134
Figure 8-12: Existing (left) and Proposed Future (right) Allision Frequency Density Maps in at MCT .....	138

### **List of Tables**

Table 2-1: Hudson River Channel USACE Report of Channel Conditions, April 2025 .....	8
Table 3-1: Summary of Surrounding Land Uses.....	14
Table 3-2: Tax Lot Ownership.....	20
Table 4-1: Minimum Depths in Each Quarter Width of the Hudson River Channel Entering from Seaward, USACE Report of Channel Conditions, April 2025 .....	23
Table 4-2: Recent Maintenance Dredging at MCT and Associated Estimated Dredge Material Quantities .....	26
Table 4-3: Summary of Existing Pier Structures within the Study Area.....	30
Table 4-4: List of Physical Aids to Navigation on the Hudson River within the Study Area .....	35
Table 5-1: Risk Register from Pilots, Deep Draft, and Tug and Barge HAZID Workshop.....	40
Table 5-2: Risk Register from City Agencies HAZID Workshop .....	43
Table 5-3: Risk Register from Ferry Operator HAZID Workshop .....	44
Table 5-4: Risk Register from Human Powered Boaters HAZID Workshop.....	46
Table 5-5: Risk Register from Adjacent and Other Users HAZID Workshop .....	48
Table 6-1: 2023 Breakdown of Vessel Crossings by Type at MCT .....	59
Table 6-2: 2023 Breakdown of Vessel Dimensions Transiting Near MCT Based on Length, Width, Draft (as reported in AIS).....	63
Table 6-3: 2023 Existing Passing Vessels at MCT Affected by Proposed Project.....	72
Table 6-4: Input Parameters Required for USACE VWPT .....	78
Table 6-5: Design Scenarios Executed for the Vessel Wake Assessment .....	82
Table 6-6: Vessel Wake Analysis Results for Existing and Proposed Conditions at MCT .....	84
Table 6-7: Summary Table of Temporary Impacts to Navigation .....	95
Table 7-1: List of Icon Class Dimension Specifications .....	99

Table 7-2: List of Icon Class Tonnage Specifications .....	99
Table 7-3: List of Icon Class Propulsion Characteristics .....	99
Table 7-4: Desktop Navigation Simulation Run Matrix .....	101
Table 7-5: Grading Description for the End Result of the Simulation .....	108
Table 7-6: Grading Description for Ship Handling Difficulty.....	108
Table 7-7: Summary Table of Desktop Navigation Simulation Outputs .....	110
Table 8-1: Historical Accident Rates from MISLE Database from 2000 through 2024 .....	114
Table 8-2: Overall SIREN Model Results for Existing Conditions in the Study Area.....	124
Table 8-3: Overall SIREN Model Results for Proposed Future Conditions in the Study Area .....	124
Table 8-4: Existing Collision Risk Frequency Broken Down by Vessel Type .....	127
Table 8-5: Proposed Future Collision Risk Frequency Broken Down by Vessel Type.....	127
Table 8-6: Existing Grounding Risk Frequency Broken Down by Vessel Type.....	130
Table 8-7: Proposed Future Grounding Risk Frequency Broken Down by Vessel Type.....	130
Table 8-8: Existing Allision Risk Frequency Broken Down by Vessel Type .....	133
Table 8-9: Proposed Future Allision Risk Frequency Broken Down by Vessel Type.....	133
Table 8-10: Existing Allision Risk Frequency at MCT Broken Down by Vessel Type .....	137
Table 8-11: Proposed Future Allision Risk Frequency at MCT Broken Down by Vessel Type .....	137

## *List of Appendices*

**Appendix A : Project Risk Register**

**Appendix B : HAZID Workshop Minutes**

**Appendix C : Existing 2023 Vessel Traffic Line Plots**

**Appendix D : Existing 2023 Vessel Traffic Density Maps**

**Appendix E : Existing 2024 Vessel Traffic Line Plots**

**Appendix F : Existing 2024 Vessel Traffic Density Maps**

**Appendix G : 2024 Vessel Crossing Statistics**

**Appendix H : 2024 Cruise Ship Calls at MCT**

**Appendix I : 2024 Proposed Footprint Impact Analysis**

**Appendix J : Desktop Navigation Simulation Summary Reports**

**Appendix K : DHI's SIREN Model**

## Glossary of Terms

AIS – Automatic Identification System	MCT – Manhattan Cruise Terminal
AOR – Area of Responsibility	MISLE – Marine Information for Safety and Law Enforcement
AWOIS – Automated Wreck and Obstruction Information System	MLLW – Mean Lower Low Water
BOEM – Bureau of Ocean Energy Management	MSZ – Maritime Security Zone
CDR – Controlling Depth Report	MTSA – Maritime Transportation Security Act of 2002
CFR – Code of Federal Regulations	N – North
COTP – Captain of the Port	NEPA – National Environmental Policy Act
DEM – Digital Elevation Model	nmi – Nautical Miles
DMMP – Dredge Materials Management Planning	NOAA – National Oceanic and Atmospheric Administration
DNS – Desktop Navigation Simulation	NSRA – Navigation Safety Risk Assessment
DNV – Det Norske Veritas	NYC – New York City
ENC – Electronic Navigation Chart	NYCEDC – New York City Economic Development Corporation
ft – feet	NYCDEP – New York City Department of Environmental Protection
ft <sup>2</sup> – square feet	NYPD – New York City Police Department
FDNY – New York City Fire Department	RCCL – Royal Caribbean Cruise Lines
GPS – Global Positioning System	SAR – Search and Rescue
HARS – Historic Area Remediation Site	USACE – United States Army Corps of Engineers
HAZID – Hazard Identification	USCG – United States Coast Guard
HOPS – Harbor Operations Subcommittee	VHF – Very High Frequency
HRCS – Hudson River Community Sailing	VMRS – Vessel Movement Reporting System
HRGS – Hudson River Ground Stabilization	VTS – Vessel Traffic Services
ISPS – International Ship and Port Facility Security	VWPT – Vessel Wake Predictor Tool
m – meters	W – West
m/s – Meters Per Second	WRDA – Water Resources Development Act
MAPONYNJ – The Maritime Association of the Port of New York & New Jersey	

## Executive Summary

The Navigation Safety Risk Assessment for the Manhattan Cruise Terminal, prepared by Hatch for the New York City Economic Development Corporation, evaluates the navigational impacts of the November 2025 MCT Master Plan. The Plan is designed to right-size the facility to accommodate modern cruise vessels, fully electrify the terminal to support sustainable operations, and foster a diversified working waterfront with public access and open spaces for New Yorkers and visitors alike. To achieve these goals, the Plan replaces the aging Piers 88, 90, and 92 with two new piers extending approximately 198 meters (650 feet) beyond current channel limits into the Hudson River. This footprint expansion requires the deauthorization of a portion of the Federally Authorized Hudson River Channel in the area associated with the following coordinates (see Figure 1-4) and encompassing approximately 10.0 hectares (24.7 acres) in area:

- 40°46'15.84"N ; 74°00'04.9"W
- 40°46'12.68"N ; 73°59'57.24"W
- 40°46'01.62"N ; 74°00'15.09"W
- 40°45'58.52"N ; 74°00'07.71"W

The authorized channel in the region of the terminal is approximately 861 meters (2,825 feet) wide and between 12.2 to 14.6 meters (40 to 48 feet) below Mean Lower Low Water (Hudson River Channel Reaches D, E, and F). In accordance with the Water Resources Development Act, a comprehensive safety assessment in the form of this Navigation Safety Risk Assessment was conducted to ensure continued safe and efficient use of the river by all maritime stakeholders.

The scope of the assessment included baselining conditions in the study area; analyzing the project's temporary and future impacts on marine traffic, on cruise ship maneuvers, and due to vessel wakes; identification and assessment of navigational risk; stakeholder consultation; and development of practical mitigation measures. As an additional scope item, desktop navigation simulations were conducted using an Icon Class design vessel to understand the feasibility of maneuvering cruise ships at the redeveloped terminal.

The scope was conducted over a four-month period by the Hatch team in partnership with DHI and in consultation with NYCEDC and other key stakeholders. Overall, the NSRA supports the proposed redevelopment of the Manhattan Cruise Terminal and the associated channel deauthorization. Primary findings from the study include:

- Based on historical AIS data, approximately 93.61% of Hudson River vessel traffic is expected to be unimpacted by the MCT redevelopment.
- There is a marginal increase in risk of allisions and collisions, and no increased risk of groundings.
- Icon Class-sized cruise ships are capable of safely berthing and unberthing at the new terminal.

- Stakeholders are generally in support of the project, with human powered boaters expressing concerns with respect to safe navigation around the new terminal, and all stakeholder groups proposing practical mitigation measures.

The initial phase of the NSRA included an assessment of maritime regulations, land use, and zoning, as well as establishment of a study domain. The boundaries for the study area were developed based on typical cruise ship maneuvering profiles at MCT while also capturing a robust level of ferry, commercial, cruise, and other vessel traffic in the vicinity. This study domain was also used to baseline existing conditions in the vicinity of the terminal to understand existing vessel traffic and to later analyze the overall effect of the proposed terminal redevelopment. The following was determined in the initial stages of the study:

### **Regulatory and Land Use**

- Maritime Security Zone surrounding MCT will likely require formal amendment during redevelopment.
- Proposed redevelopment is not expected to negatively impact existing or planned land uses.

### **Study Domain and Physical Conditions**

- NYCEDC-maintained dredge area will increase, but overall dredged footprint in the Hudson River remains unchanged.
- Existing electronic and physical aids to navigation remain effective and additional aids may be installed post-redevelopment.
- Environmental factors (currents, tides, wind) pose inherent navigational risk in any terminal layout and were quantitatively assessed to determine impacts to vessel navigation in the later stages of the study.

Historical AIS data were used to determine existing vessel traffic patterns around the terminal. These traffic patterns were then offset based on the proposed layout to determine the overall impact to vessel transits during construction phases and into the future. To assess the long-term impacts of the proposed redevelopment, the study employed a quantitative risk model that integrated vessel behavior, environmental conditions, and traffic rules. The model simulated vessel movements and interactions under both existing and future conditions, quantifying the likelihood of collisions, groundings, and allisions. A vessel wake impact assessment was conducted to quantify the anticipated wake effects on the terminal resulting from transiting vessels. The following impacts to cruise ship and other vessel traffic in the Hudson were observed:

### **Project Impact Analysis**

- Based on historical AIS data, approximately 93.61% of Hudson River vessel traffic is expected to be unimpacted by the MCT redevelopment.
- The maximum significant wave height expected to impact the redeveloped terminal from passing cargo ship wakes is estimated at 0.79 meters (2.59 feet), compared to 0.71 meters (2.33 feet) for the terminal in its current condition.

## Risk Modeling

- Model validated against 25 years of USCG MISLE data.
- Grounding risk unchanged from the current condition, with a slight increase in allision and collision risk due to the expanded terminal footprint and projected increase in cruise and other vessel traffic.
- Based on the quantitative risk assessment, it is predicted that there will be ~1 additional accident (collision or allision) every 17 years.

Complementing the risk modeling, a series of desktop navigation simulations were conducted. It is anticipated that the largest cruise vessels will continue serving major hubs in the U.S. Gulf and Florida. Meanwhile, the next-largest classes are expected to call at MCT in the future. Based on market projections and the current cruise ship orderbook, the Icon Class vessel was used for the project impact analysis and desktop navigation simulations to represent this second tier of vessel size, as it is the vessel class sailing today which most closely aligns with the vessels expected to call at the redeveloped MCT.

## Desktop Navigation Simulations

- Simulations incorporated realistic constraints, including thruster limits, adjacent moored vessels, and typical extreme environmental conditions experienced on the Hudson, with consultation from New York Harbor ship pilots.
- The simulations confirmed that the Icon Class design vessel can berth and unberth under typical extreme environmental conditions with enough clearance for the possibility to correct minor maneuvering difficulties without compromising safety.
- Out of the 12 simulation runs with the Icon Class, 7 were completed with a completion grade of Successful and 5 with Marginal (indicating sustained use of high thruster power).

Stakeholder engagement was a critical component of the assessment, with input gathered through hazard identification workshops involving harbor and docking pilots, tug and barge operators, ferry and passenger vessel companies, New York City agencies, and human powered boaters. Participants in these sessions identified key concerns, including vessel congestion, visibility and environmental condition limitations, lack of real-time cruise ship scheduling information, and communication challenges for human powered boaters operating near the terminal. In response, the report recommends a suite of mitigation strategies, including enhanced vessel traffic coordination, AIS-based monitoring, public awareness campaigns, improved signage, and updates to operational procedures to address both temporary impacts during construction and long-term operational challenges. These measures are designed to mitigate the risks identified by stakeholders, while also looking to reduce the probability of allisions, collisions, and groundings identified through the risk modeling.

In summary, the Navigation Safety Risk Assessment supports the proposed redevelopment of the Manhattan Cruise Terminal and the associated channel deauthorization. The modest increase in navigational risk is localized and manageable and, with implementation of appropriate mitigations, the expanded terminal would not impede the safe and efficient use of the Hudson River waterway.

## 1. Study Background

The Manhattan Cruise Terminal (MCT), located along Manhattan's West Side Highway (Route 9A) between West 48<sup>th</sup> St. and West 52<sup>nd</sup> Street and at river mile marker 4 on the Hudson River, consists of Piers 88, 90, and 92. The terminal is operated by Ports America and is bordered by Pier 86 (Intrepid Museum) to the south and Pier 94 to the north. Originally built in the late 1930s to accommodate the era's largest ocean liners, its development was supported by the Rivers and Harbors Act of 1937, which extended and deepened the Hudson River Channel to facilitate passenger operations. Each pier extends 335 meters (1,100 feet) and the terminal features a total of five berths designed to accommodate cruise ships, numbered 1-5 starting from the south side of Pier 88.

Over the past ninety years, MCT has transformed into North America's fifth-largest homeport, serving approximately one million cruise passengers annually. The cruise industry contributes an estimated \$500+ million each year to New York City's economy through direct spending on goods, services, tourism, and transportation by passengers while ashore.

Today, however, the terminal's 90-year-old infrastructure has reached the end of its useful life; now, only three berths are usable for cruise ship operations. It no longer meets the evolving needs of the industry or the surrounding community. In response, the New York City Economic Development Corporation (NYCEDC), which manages the City-owned MCT, launched a Master Planning initiative in 2024 to identify critical capital improvements needed to ensure the terminal remains a sustainable, inclusive, and productive gateway to New York City.

With the continued arrival of longer and higher passenger capacity vessels, and growing demand for shore power and public access, NYCEDC determined that the new facility must extend further into the Hudson River to accommodate these needs.

The proposed terminal would include the demolition of all three existing piers and the reconstruction of a new North Pier and South Pier in the approximate locations of the existing Piers 88 and 92. The new North and South Piers will extend approximately 198 meters (650 feet) farther into the Hudson River beyond the current channel limit than the existing terminal. This extension will accommodate two cruise ships similar in size to the design vessel in the center berths and one vessel similar in size to what is currently calling at MCT on the southern side of the southern pier. The extended piers and new terminal layout will also incorporate critical community priorities. The proposed development project (the "Proposed Project") is shown in Figure 1-4.

Because the existing piers at MCT directly border the Federally Authorized Channel, any proposed extension into the Hudson River would require the deauthorization of a portion of that channel. The deauthorization of a Federally Authorized Channel is governed by federal legislation, specifically the Water Resources Development Act (WRDA). A key requirement for initiating this process is the completion of a Navigational Safety Risk Assessment (NSRA), which evaluates the potential impacts of deauthorization on maritime safety and operations.

Therefore, to support this effort, NYCEDC coordinated a comprehensive study to assess the implications of the proposed channel modification. The scope of the study involved three distinct tasks:

- Task 1: Analysis of the present and projected future use of the Federally Authorized Channel, in accordance with US Army Corps of Engineers (USACE) standards, to achieve deauthorization.
- Task 2: Discussions, meetings, presentations, and communication of findings with USACE and the US Coast Guard (USCG).
- Task 3: Preparation of a technical report to summarizing the findings of the NSRA.

Task 1 included an assessment of the baseline conditions of vessel traffic in the area around MCT using publicly available Automatic Identification System (AIS) data, analysis of the impacts that the redeveloped terminal would have on vessel traffic and cruise ships maneuvering at MCT, identification of the risks and hazards associated with the proposed redevelopment through AIS modeling and stakeholder engagement, and the development of practical mitigation strategies to address any concerns raised.

Task 2 included targeted consultation with maritime stakeholders throughout New York Harbor. Engagement paid particular attention to human powered boaters, such as kayakers, paddleboarders, and other craft that are not equipped AIS tracking devices and thus cannot be quantified in the risk modeling. These users are differentiated from recreational boaters, such as motorized pleasure craft and sail boats that may be equipped with AIS transponders. This part of the scope was key to determine practical mitigation measures.

An additional part of the analysis included a two-dimensional desktop navigation simulation was conducted to provide deeper insight into the navigational challenges associated with cruise vessel arrivals and departures at the proposed terminal. This work was conducted to enhance the understanding of maneuvering feasibility and safety beyond what could be achieved through earlier AIS analysis alone.

The NSRA, including stakeholder engagement and 2D simulations, has been conducted to determine whether deauthorizing the Federally Authorized Channel and the proposed redevelopment of MCT will affect safe, efficient, and continued use of the Hudson River by all maritime stakeholders. Overall, it was determined that the proposed redevelopment of the Manhattan Cruise Terminal and the associated channel deauthorization only marginally increases the overall risk for vessel traffic in this area of the Hudson River.



**Figure 1-1: Navigation Safety Risk Assessment Study Area, in the Context of the Upper New York Harbor with the Existing MCT Condition**

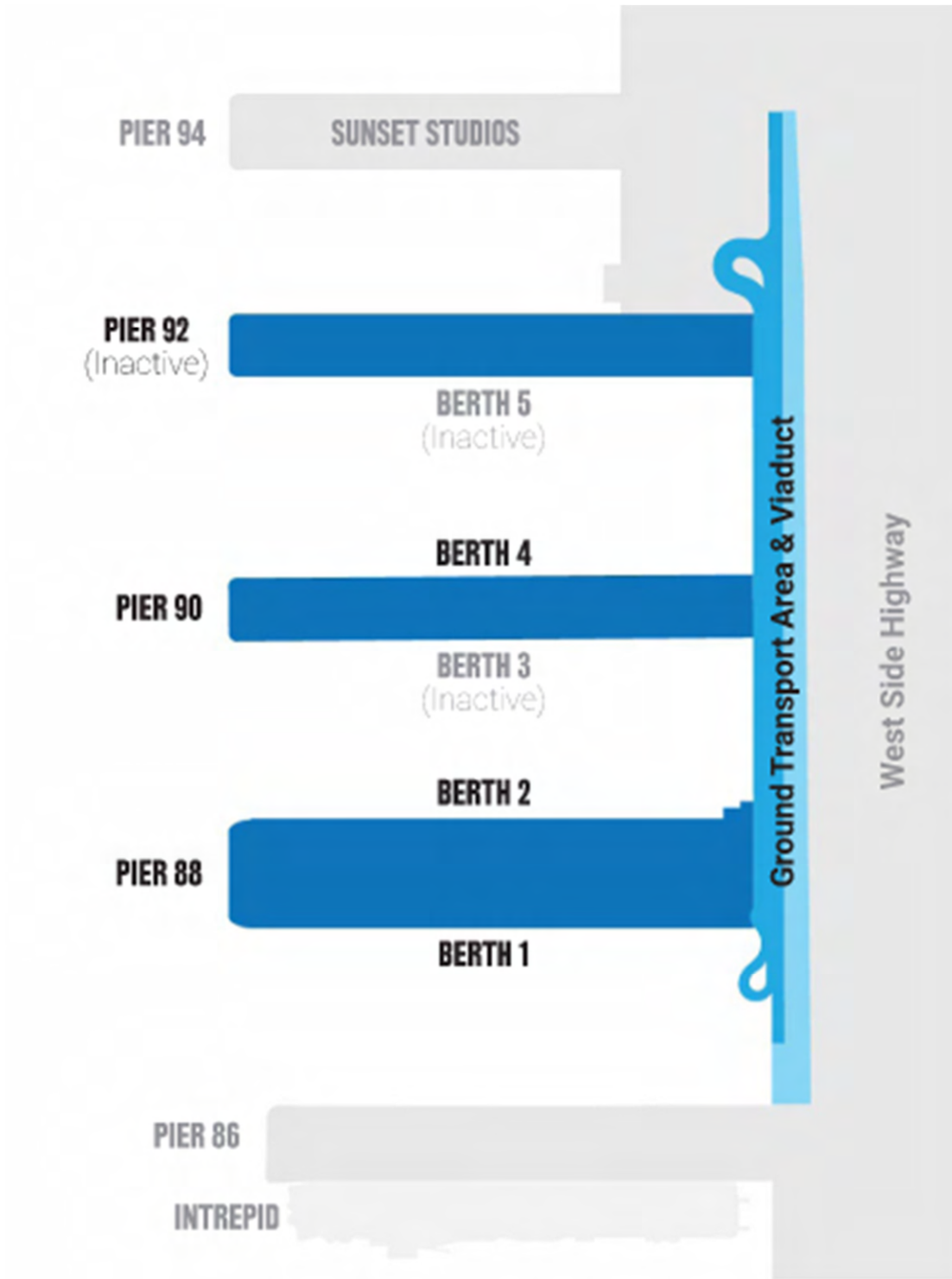
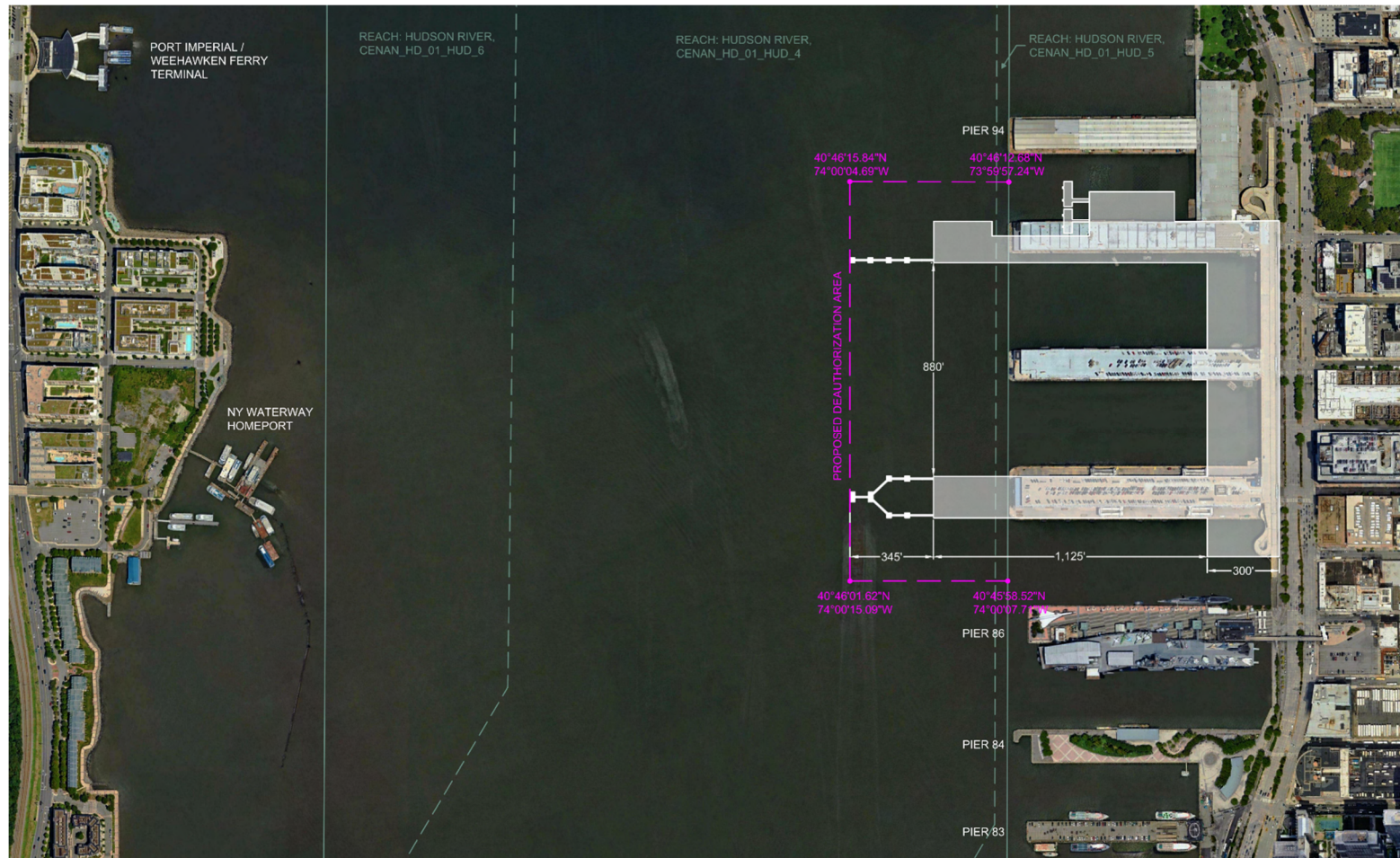


Figure 1-2: Berth Layout at MCT in its Current Configuration



**Figure 1-3: Channel Descriptions in Study Area**



**Figure 1-4: Proposed Configuration of Manhattan Cruise Terminal Redevelopment**

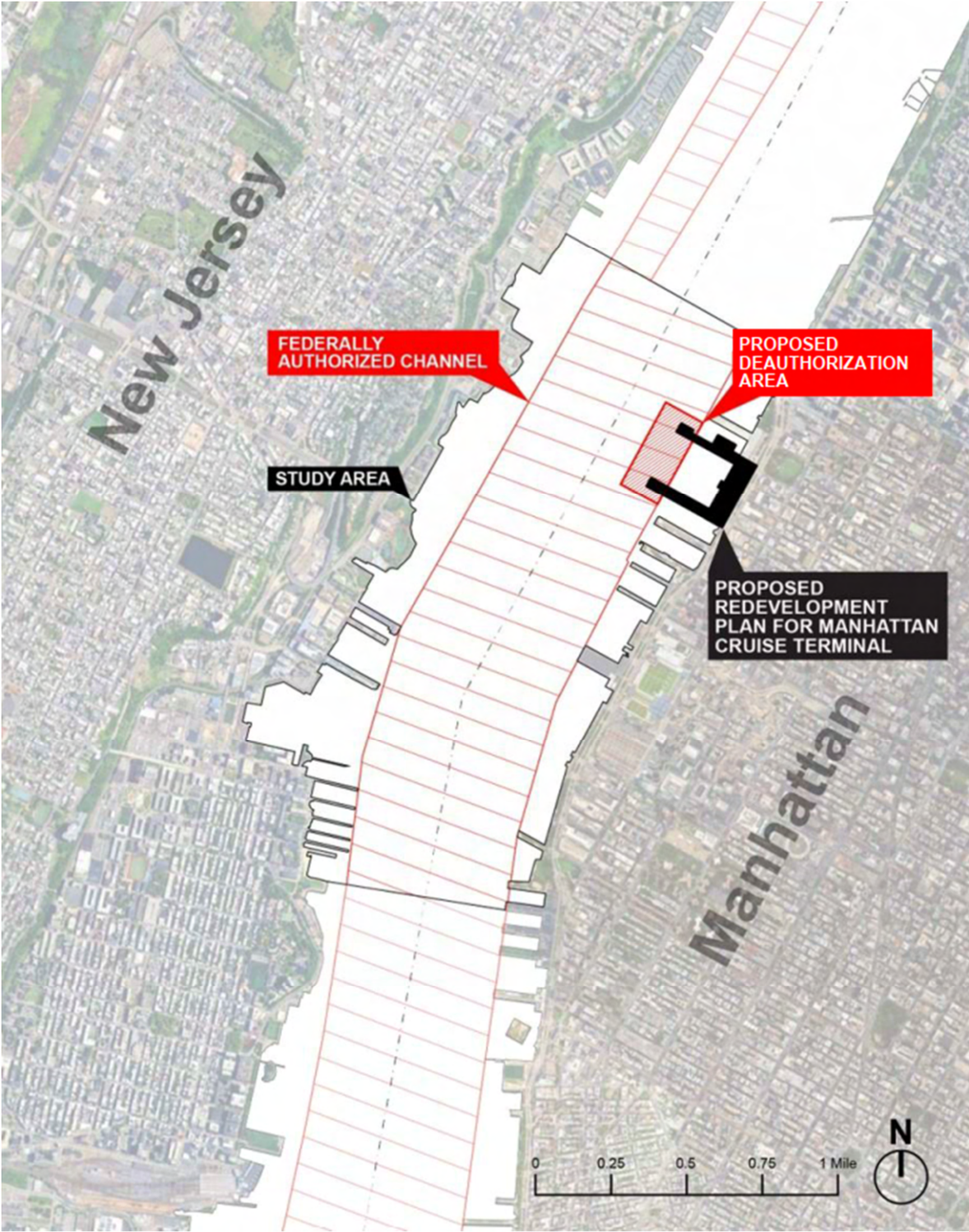


Figure 1-5: Study Area with Proposed Project Footprint and Estimated Deauthorization Area

## 2. Federally Authorized Channel and Study Area Description

### 2.1 Hudson River Channel

The Hudson River flows north to south, originating in the Adirondack Mountains and flowing through New York Bay before draining into the Atlantic Ocean. The southern extent is bordered by New Jersey to the west and New York to the east, with the southernmost portion flowing alongside the New York City borough of Manhattan.

The Hudson River Federally Authorized Channel, maintained by USACE, was created in response to the centuries of commercial activity that made the river a vital economic corridor. As industrialization surged in the 19<sup>th</sup> century, the river became lined with factories, shipyards, and ports, necessitating deeper and more reliable navigation routes. To support this economic expansion, Congress authorized the creation and improvement of the Hudson River Channel through the Rivers and Harbors Acts between 1910 and 1954.<sup>1</sup> The channel today runs approximately 6 miles at a width of around 609 meters (2,000 feet), from the Upper New York Bay to West 59<sup>th</sup> Street, and then an additional 5 miles north of West 59<sup>th</sup> Street, at a width of 228 meters (750 feet), along the New Jersey waterfront. Nearly 10.7 million tons of freight traffic is transported through the channel annually, in addition to the over 1 million passengers served by MCT.<sup>2</sup> An image of the channel extents is shown in Figure 2-1.

The Channel is divided into eleven reaches, which range in authorized depth from 9.1 to 14.6 meters (30 to 48 feet). USACE’s 2025 Report of Channel Conditions is shown below in Table 2-1.

**Table 2-1: Hudson River Channel USACE Report of Channel Conditions, April 2025**

Channel Reach	Width (ft)	Length (nmi)	Depth (ft)
<b>Reach A (Center):</b> Commences at the entrance of the channel at the junction with Anchorage Channel (adjacent to Governors Island) and continues to the approximate location of West 40 <sup>th</sup> Street in NYC.	2,000	4.42	45
<b>Reach B (New Jersey):</b> Commences approximately 1,400 feet landward of the commencement of Reach A and continues to a point at the approximate location of W40th St in NYC.	215 – 850	3.74	40
<b>Reach C (New York):</b> Commences approximately 2,230 feet landward of the commencement of Reach A at the junction with the East River and continues to a point at the approximate location of West 40 <sup>th</sup> Street in NYC.	487 – 1,000	4.01	40

<sup>1</sup> US Army Corps of Engineers, New York District. *Fact Sheet: Hudson River, NYC to Waterford, NY Maintenance Dredging*. Last modified January 15, 2025. Accessed October 12, 2025. <https://www.nan.usace.army.mil/Media/Fact-Sheets/Fact-Sheet-Article-View/Article/487349/fact-sheet-hudson-river-nyc-to-waterford-ny-maintenance-dredging/>.

<sup>2</sup> US Army Corps of Engineers, New York District. *Fact Sheet: Hudson River Channel, NY (40 FT)*. <https://www.nan.usace.army.mil/Media/Fact-Sheets/Fact-Sheet-Article-View/Article/487535/fact-sheet-hudson-river-channel-ny-40-ft/>. Accessed October 9, 2025.

Channel Reach	Width (ft)	Length (nmi)	Depth (ft)
<b>Reach D (Center):</b> Commences at the approximate location of West 40 <sup>th</sup> Street in NYC, and continues to the approximate location of Pier 99 around West 59 <sup>th</sup> Street.	2,000	0.87	48
<b>Reach E (New Jersey):</b> Commences at the approximate location of West 40 <sup>th</sup> Street in NYC, and continues to a point at the approximate location of Pier 99 in NYC around West 59 <sup>th</sup> Street.	265 – 775	0.86	40
<b>Reach F (New York):</b> Commences at the approximate location of West 40 <sup>th</sup> Street in NYC, and continues to a point at the approximate location of Pier 99 in NYC around West 59 <sup>th</sup> Street.	50 – 317	0.85	40
<b>Reach G:</b> Commences at the approximate location of Pier 99 in NYC around West 59 <sup>th</sup> Street and continues to a point located approximately opposite West 75 <sup>th</sup> Street in NYC.	750	0.72	30
<b>Reach H:</b> Commences at a point located approximately opposite West 75 <sup>th</sup> Street in NYC and continues to a point located approximately 8,400 feet landward of the beginning of the reach (in the approximate vicinity of opposite West 107 <sup>th</sup> Street in NYC).	750	1.38	30
<b>Reach I:</b> Commences at a point located in the approximate vicinity of opposite West 107 <sup>th</sup> Street in NYC and continues to the approximate location of the Amerada Hess Oil Terminal Wharf (in the approximate vicinity of opposite West 122 <sup>nd</sup> Street in NYC).	750	0.61	30
<b>Reach J:</b> Commences at the approximate location of the Amerada Hess Oil Terminal Wharf (in the approximate vicinity of opposite West 122 <sup>nd</sup> Street in NYC) and continues to a point located approximately opposite the New York City Department of Sanitation Marine Transfer Station Barge Slip (in the approximate vicinity of opposite West 135 <sup>th</sup> Street in NYC).	750	0.57	30
<b>Reach K:</b> Commences at a point located approximately opposite the New York City Department of Sanitation Marine Transfer Station Barge Slip (in the approximate vicinity of opposite West 135 <sup>th</sup> Street in NYC) and continues to approximately opposite West 156 <sup>th</sup> Street in NYC.	750	0.97	30
<p>Notes:</p> <p>All reported depths are the Authorized Project Depths relative to the Mean Lower Low Water (MLLW) datum. Channel reach lengths are in nautical miles.</p>			

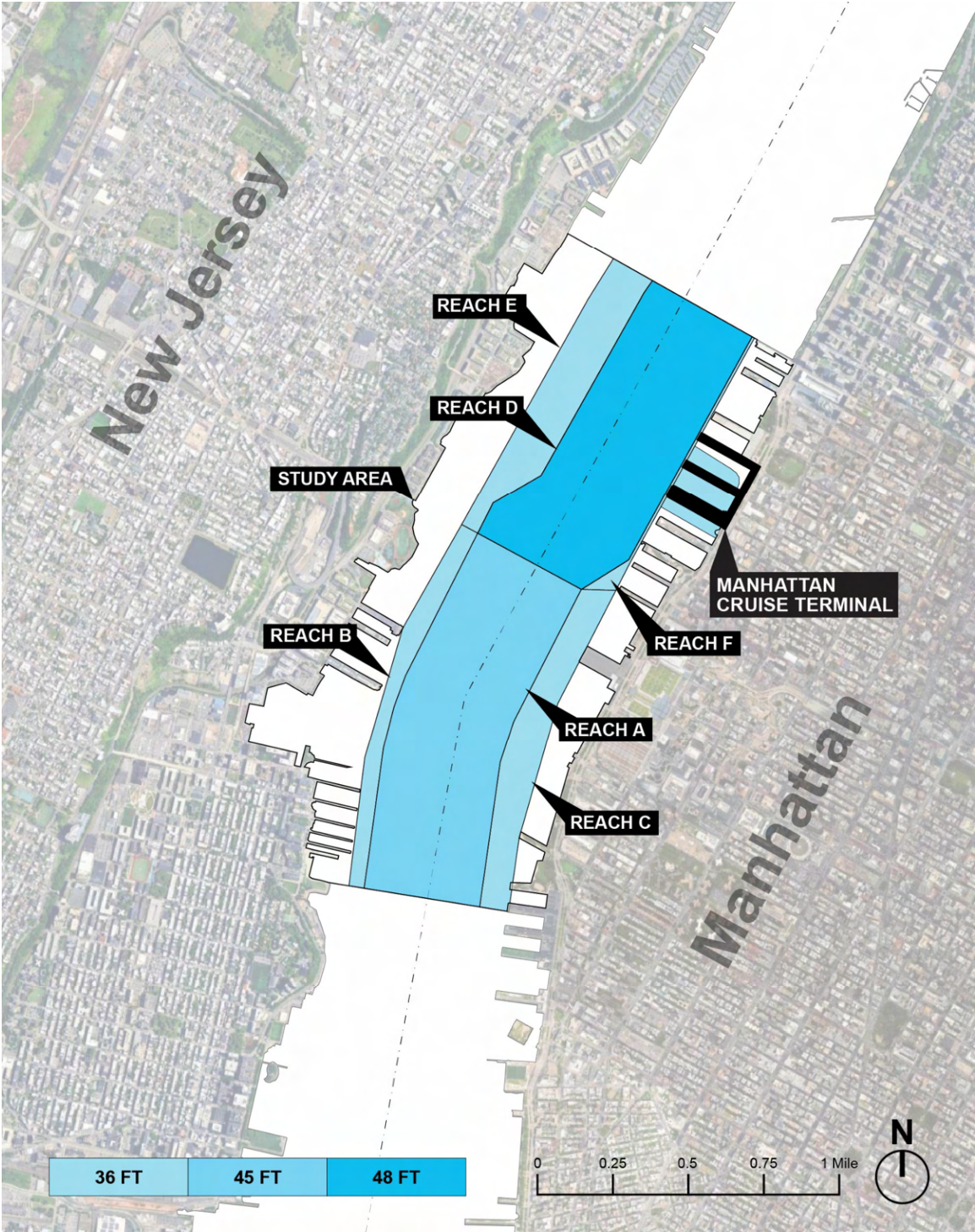


Figure 2-1: Channel and MCT Basin Dredge Depths<sup>3</sup>

## 2.2 Summary of Current Regulations

### 2.2.1 *The United States Army Corps of Engineers*

The safe navigation of cruise ships depends not only upon accurate aids to navigation, under the umbrella of USCG, but also on up-to-date bathymetric surveys, established channel and berth maintained depths, and appropriate under-keel clearance policies.

USACE, New York District, is the federal lead for maintaining Federally Authorized Channels in the Port of New York & New Jersey. They are responsible for surveying, reporting controlling depths, contracting maintenance dredging, managing dredged material placement consistent with the Dredge Materials Management Planning (DMMP), and managing permitting through the National Environment Policy Act (NEPA) and WRDA authorities.

USACE conducts scheduled surveys and subsequently provides Controlling Depth Reports (CDRs). This is followed by immediate dredging of high points, as necessary, to maintain a minimum depth in the established channels. USACE implements regular, periodic maintenance dredging under a regional DMMP in order to maintain or improve safe navigation in the Federally Authorized Channels of the port.

Dredge volumes and frequency are site-specific and are influenced by local sedimentation rates, upstream construction influence, vessel traffic, storm events, and contract bundling (USACE often packages many reaches in a single maintenance contract).

### 2.2.2 *The United States Coast Guard*

The New York Sector of USCG, through the office of the COTP and VTS, works closely with USACE to ensure the continuous, safe, smooth operation of the harbor. USCG is responsible for enforcement of maritime regulations, the planned location and monitoring of all aids to navigation, VTS operations, establishment of safety and security zones, planning of tug escort/tug assist, and pilot support. The USCG introduces and enforces safety rules, issues Notices to Mariners, and provides environmental protection oversight of the waterfront in all marine aspects, having the overall statutory authority to restrict vessel movements. The latter includes cruise ships through the application of VTS rules and regulations.

USCG also upholds international marine commitments such as the International Maritime Organization and International Ship and Port Security (ISPS) rules and regulations.

#### 2.2.2.1 *Maritime Security Zone*

USCG is the designated authority responsible for implementing the ISPS in the USA, known as the Maritime Transportation Security Act of 2002, which includes security obligations for both US Vessels and US Ports. As such, USCG is the responsible authority that establishes and enforces safety and security zones as established in their Coast Guard Notices and Regulations and Notices to Mariners and Local Notice to Mariners.

---

<sup>3</sup> Esri. *ArcGIS Web Map Viewer*. Accessed October 12, 2025.  
<https://www.arcgis.com/home/webmap/viewer.html?webmap=cf0bae8d7d89464587ff2b97d37f9267>.

At MCT, a permanent USCG safety and security zone has been established to restrict waters off the terminal boundaries. The zone is enforceable at all times but security enforcement criteria may change based on the facility security plan if the USCG Maritime Security level changes at the facility or based on a COTP order. In general, the Facility Security Officer at MCT will decide on the type of enforcement required during a breach.

The boundaries of the current maritime security zone surrounding MCT would be subject to change based on the Proposed Project. This would involve coordinating with USCG, stakeholder engagement, preparation of a technical package, and public outreach. The process to amend the boundaries of the security zone would occur at a later stage of the redevelopment process.

## 2.3 Study Area

### 2.3.1 *Metes-and-Bounds Methodology*

As the Proposed Project extends into the Federally Authorized Channel, a specific footprint for deauthorization is required to be delineated. This area should be sufficient to encompass the redeveloped layout of MCT, while minimizing the impact on vessel traffic in the waterway. This section explains how the proposed boundaries of the deauthorization area surrounding the redeveloped MCT within the Hudson River Federally Authorized Channel were defined.

The assessment of the metes-and-bounds of the deauthorization area focused on the boundaries north, south, east, and west to identify a deauthorization footprint that provides sufficient space for the redeveloped layout of MCT, as described below and highlighted in Figure 1-4.

- **Northern boundary:** Based on the northern face of the North Pier within the Federally Authorized Channel, offset by the beam of the largest expected vessel at the ferry berth—FDNY’s Three Forty Three (11.0 m (36 ft) beam)—plus a 15.2 m (50 ft) buffer to account for design/regulatory unknowns.
- **Western boundary:** Aligned with the western face of the westernmost dolphin.
- **Eastern boundary:** Currently estimated to intersect with existing Federally Authorized Channel limits.
- **Southern boundary:** Based on the southern face of the South Pier within the Federal Channel, offset by the beam of largest expected vessel at the berth—the Breakaway Plus Class vessel (51.5 m (169 ft)) —plus a 15.2 m (50 ft) buffer for design/regulatory unknowns.

### 2.3.2 *Proposed Deauthorization Area*

This deauthorization area encompasses an estimated 10.0 hectares (24.7 acres, or 1 million ft<sup>2</sup>). These boundaries formed by the following coordinates the framework for identifying the study area for this assessment.

- 40°46'15.84"N ; 74°00'04.9"W

- 40°46'12.68"N ; 73°59'57.24"W
- 40°46'01.62"N ; 74°00'15.09"W
- 40°45'58.52"N ; 74°00'07.71"W

### 2.3.3 **NSRA Study Area Definition**

In order to fully understand the potential impacts of the Proposed Project, a study area for this NSRA was determined through the consideration of typical cruise ship maneuvers at MCT and the impacts that the new proposed MCT configuration may have on existing vessel traffic.

The NSRA study area (the “Study Area”) extends from the shoreline of Manhattan on the east to the shoreline of New Jersey on the west and from Pier 99 in the north to Pier 61 in the south. The length of the Study Area is from approximately river mile 3.2 to river mile 5.3 on the Hudson (with river mile 0 at The Battery), and the maximum width of the study area is approximately 1.05 miles, on a line drawn perpendicular from Manhattan just south of Pier 66 to New Jersey. The Study Area is shown in Figure 1-1.

Pier 99 was used as the northern extent of the study area as it is the northernmost active pier in the vicinity and is in line with the northernmost point that cruise ships typically maneuver during unberthing. The southernmost extent of the study area was determined to be Pier 61 (Chelsea Piers), which coincides with the vicinity in which cruise ships typically begin deceleration for berthing at MCT. As this is where cruise ships begin their approach for arrival at MCT, it was determined that deauthorization of the federally authorized channel for the Proposed Project would not impact operations on the Hudson south of this boundary.

The Study Area captures ferry traffic from key ferry landings and terminals including Port Imperial, Hoboken 14<sup>th</sup> Street, and NY Waterway’s Weehawken yard in New Jersey, as well as from Pier 79 in Manhattan. The Study Area likewise encompasses commercial vessel traffic, including bulk carriers, tugs & barges, and tankers, transiting on the Hudson, as well as other passenger vessel traffic. Adjacent active piers are also incorporated into the Study Area.

## 3. **Land Use and Zoning Analysis**

The NYCEDC Land Use Department developed this section of the report. The information presented herein has been gathered through a review of the latest MapPLUTO 25v2.1 dataset (MapPLUTO).

### 3.1 **Overview**

To better understand the surrounding area, this section of the NSRA analyzes land uses and properties within a 122-meter (400-foot) radius (the “Land Use Study Area”) of the future piers, shoreline, and upland conditions (the “Project Site”), which is inclusive of 23 tax lots. These 23 tax lots have at least 50% of their area within the 122-meter (400-foot) radius. Tax lots that do not have at least 50% of their area within the 122-meter (400-foot) radius are

excluded from this analysis. These tax lots were then reviewed for existing land uses, ownership type, and owners using the MapPLUTO data. In addition to land uses, consideration of transportation available near the Land Use Study Area was reviewed, which can be seen in Figure 3-4.

### 3.2 Summary of Surrounding Land Uses

As shown in Table 3-1 below, there are 23 lots that have at least 50% of their lot area located within the Land Use Study Area. As shown in Figure 3-1, these lots are located directly adjacent to the waterfront, or directly east of 12<sup>th</sup> Avenue.

**Table 3-1: Summary of Surrounding Land Uses**

Land Use	Number of Lots	Lot Area (sf)	Percent of Lot Area (%)
One Family	0	0	0.0%
Multi-Family Walkup	0	0	0.0%
Multi-Family Elevator	0	0	0.0%
Mixed Residential Commercial	4	18,552	0.8%
Commercial and Office	4	22,594	1.0%
Industrial and Manufacturing	4	136,643	6.0%
Transportation and Utility	7	2,062,119 <sup>4</sup>	90.6%
Public Facilities and Institutions	0	0	0.0%
Open Space	0	0	0.0%
Parking	4	36,577	1.6%
Vacant	0	0	0.0%
Other/Unknown	0	0	0.0%
Total	23	2,276,485	100.0%

Transportation uses represent the largest number of total tax lots with a total of seven. It also covers the most amount of land area covering 90.6% of all land. Piers 88, 90, 92, and 94 constitute a significant portion of this geography. Mixed-use residential and commercial, commercial and office, industrial/manufacturing, and parking uses represent the second highest number of lots with four each. However, industrial/manufacturing uses constitute the second highest percentage of lot area with 6.0%. There are no one-family, multi-family walk-up, multi-family elevator, public facilities/institutions, open space, vacant, or unknown uses within the Land Use Study Area. As shown in Figure 3-1 and described above, the land use in

<sup>4</sup> To ensure that the data accurately reflects current conditions, one lot categorized as transportation/utility was amended to include only the area as displayed in Figure 3-1 below. Block 1110, Lot 1, which encompasses a geography that stretches from West 42<sup>nd</sup> Street in the south to West 96<sup>th</sup> Street in the north, the US Pierhead line in the east, and the NY/NJ border in the middle of the Hudson River to the west totals over 22 million square feet of area.

the Land Use Study Area reflects the general transportation, industrial, and supportive character uses of MCT.

### **3.3 Transportation**

Transportation options within the Study Area are a mix of public transportation, bike, and pedestrian options. As shown in Figure 3-4 below, the area is served by two buses, the M12 and M50. The M12 is a local north-south bus route that travels from Columbus Circle in the north to Abingdon Square in the West Village in the south. Within the Land Use Study Area, there are three bus stops for the M12 bus located. Only the north-bound route of the bus, which travels along 12<sup>th</sup> Avenue, is located within the Land Use Study Area; the M12 travels south-bound along 11<sup>th</sup> Avenue. The M50 is a local east-west bus route that travels from the United Nations in the east to Hudson River Park in the west. Within the Land Use Study Area, there is one M50 bus stop along 12th Avenue. There are no subways, commuter rail lines, ferries, or other public transit options located within the Land Use Study Area.

The area is also well served by a vast bike network. The Empire State Trail, a 750-mile multi-use trail, extends from the southern point of Manhattan in the south to the border with Canada in the north. It also goes west to Buffalo from Albany. The Empire State Trail is located adjacent to MCT and offers people a protected mixed-use walking/biking path. Currently, this portion of the trail is narrower than others, which may lead to congestion at the intersections of West 48th Street, West 49th Street, West 50th Street, and West 51st Street. There are also two cross-town bike paths, an east-bound path located on West 52nd Street and a west-bound path located on West 54th Street.

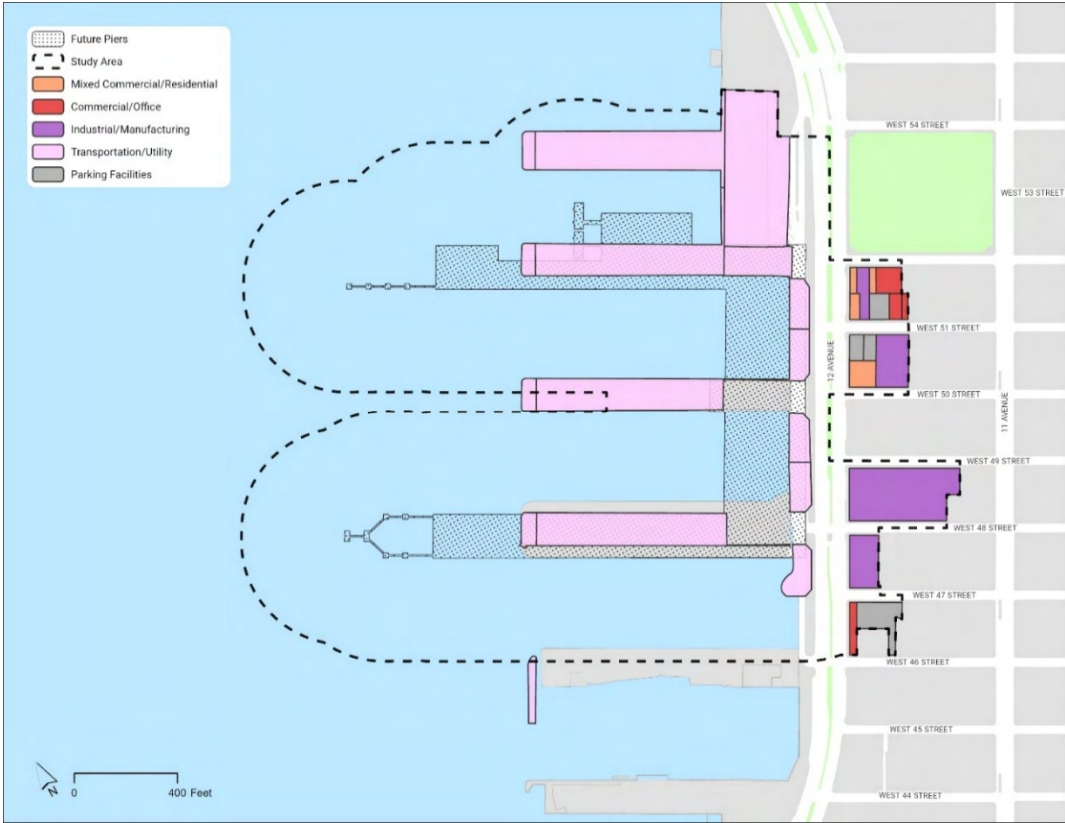


Figure 3-1: Land Uses in the Land Use Study Area Surrounding MCT

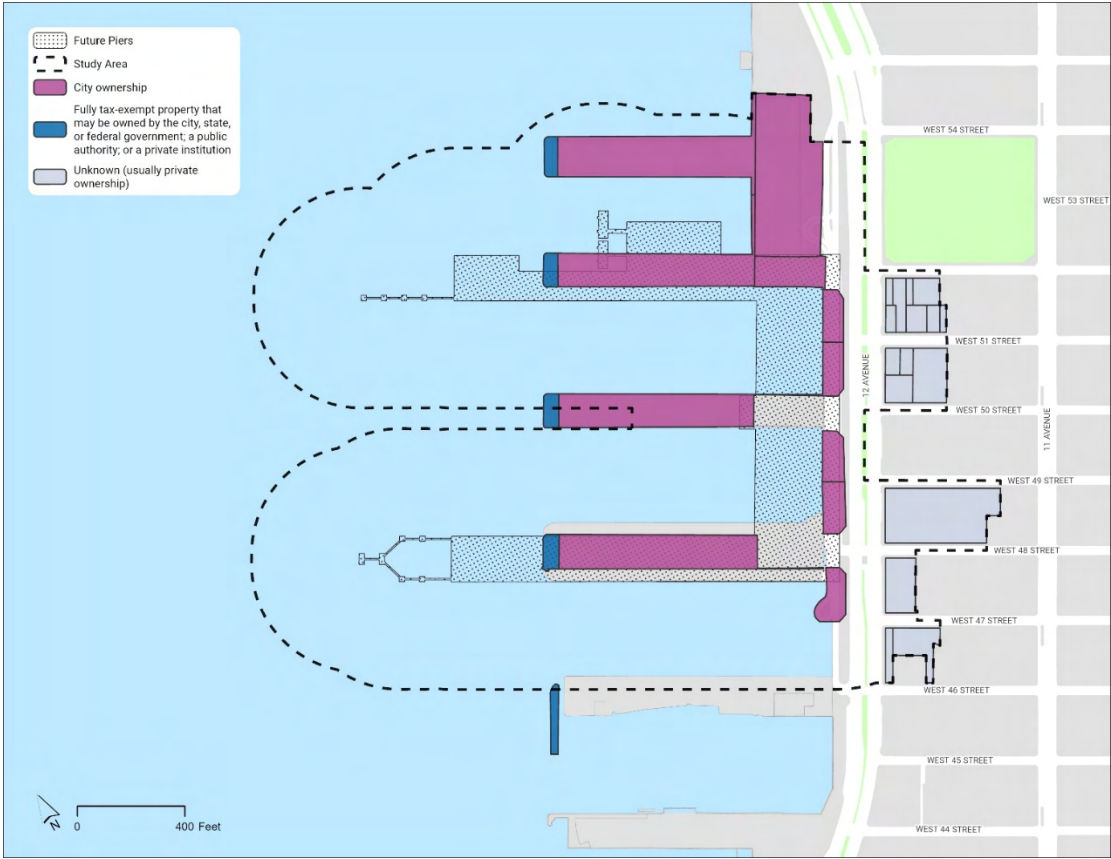


Figure 3-2: Public vs. Private Ownership of Land Use within Land Use Study Area

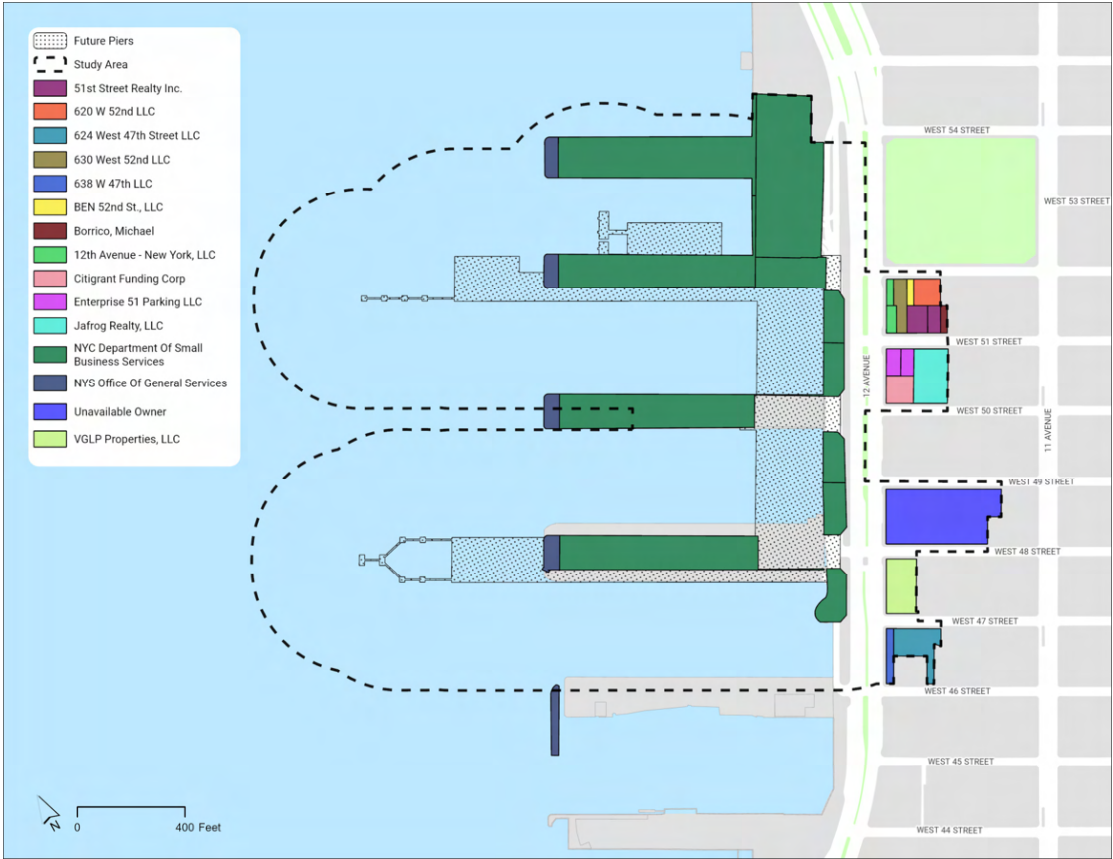
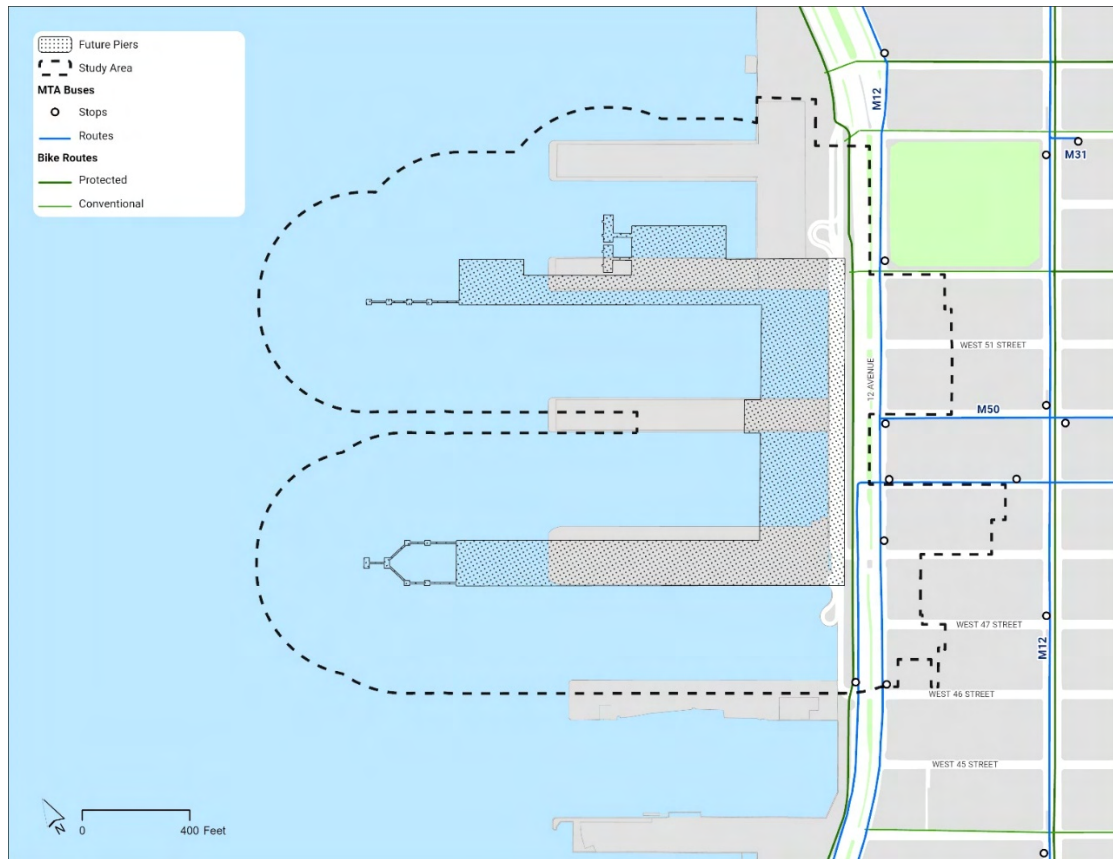


Figure 3-3: Ownership of Zones within Land Use Study Area<sup>5</sup>

<sup>5</sup> Source of ownership for Block 1109, Lots 100 and 101 confirmed with New York City Department of Finance. All other lots confirmed source of ownership with 25V2 MapPLUTO.



**Figure 3-4: Transit and Bike Paths in the Land Use Study Area**

### 3.4 Summary of Surrounding Ownership

In addition to considering the land uses of the surrounding tax lots, an analysis was completed to identify any ownership trends associated with the surrounding tax lots. For this discussion, ownership was broken into the following three categories, as shown in:

- City ownership;
- Fully tax-exempt property that may be owned by the City, state, or federal government, a public authority, or a public institution; and,
- Unknown; likely private ownership.

As shown in Table 3-2 below, the majority of the land area is City owed. The lots directly adjacent to the waterfront are City-owned and fully tax-exempt properties (see Figure 3-2). These lots include Piers 88, 90, 92, 94. City-owned lots represent the highest total land area with 89.0% of all lot area. Private entities do not own any waterfront properties; all privately owned sites are located east of 12<sup>th</sup> Avenue between West 52<sup>nd</sup> Street and West 46<sup>th</sup> Street. Though most of the lots are privately owned, they only represent 9.4% of land area. Tax-exempt lots represent the lowest total land area with 1.6%.

**Table 3-2: Tax Lot Ownership**

Ownership Type	Number of Tax Lots	Percent of Tax Lots as Total	Land Area (sf)	Land Area (as % of total)
Fully tax-exempt property that the city, state, or federal government, a public authority, or a public institution may own	1	4.3%	36,577	1.6%
Unknown; likely private ownership	16	69.6%	214,366	9.4%
City-owned	6	26.1%	2,025,542	89.0%
Totals	23	100.0%	2,276,485	100.0%

### 3.5 Previous Land Use Actions

It is also important to consider previous land use actions within the Land Use Study Area to identify any existing plans for the Land Use Study Area and determine if the proposed project would affect these plans. The New York City's Zoning and Land Use Map (ZoLa) was reviewed for any recent and relevant zoning map amendments and any special purpose districts and subdistricts in the area as of October 2025. Additional research was conducted for other important land use actions that have occurred.

Since 2000, two zoning map amendments have been adopted within the Land Use Study Area. The zoning map changes are described below:

- Verizon West 47<sup>th</sup>-48<sup>th</sup> Streets Rezoning – Adopted in 2004, this zoning map amendment (C040250ZMM) rezoned an entire block on the West Side of Manhattan bound by West 47<sup>th</sup> Street, 12<sup>th</sup> Avenue, West 48<sup>th</sup> Street, and 11<sup>th</sup> Avenue, within the Special Clinton District from an M2-3 district to an M1-5 district. This change was needed to facilitate Verizon's plans to construct a new garage and support facility for its consolidated West Side operations into one building.
- West Clinton Rezoning – Adopted in 2011, this rezoning affected the entirety or portions of approximately 18 blocks between West 43<sup>rd</sup> Street and West 55<sup>th</sup> Street in the Chelsea neighborhood of Manhattan. The rezoning extended the existing Special Clinton District westward in an effort to extend residential districts from 10<sup>th</sup> Avenue to 11<sup>th</sup> Avenue and to increase the density permitted on certain blocks zoned for manufacturing and comparable uses between 11<sup>th</sup> Avenue and 12<sup>th</sup> Avenue. Portions of this area was rezoned from manufacturing zoning districts to residential zoning districts (including R8, R8A, and R9), mixed-use residential and commercial districts, and higher density manufacturing zoning districts.

It is important to note again that all these zoning map amendments are located on the eastern side of the Hudson River, east of Route 9A, and do not directly involve any water-dependent uses. Therefore, the zoning map amendments do not affect MCT, nor would they be negatively affected by the proposed project and necessary channel deauthorization.

Directly north of MCT is Pier 94, where a new film and television production studio is located and operated by Sunset Studios. For many years, the City-owned Piers 92, 94, and the

associated headhouse served as a venue for mid-sized trade shows and exhibitions, concerts, and other events. In 2019, the Department of Buildings determined that Pier 92 was unsafe for use. In 2023, the City of New York amended and restated its lease with an affiliate of Vornado Realty Trust to remove Pier 92 from the leasehold and allow Pier 94 to be redeveloped into a dedicated film and television production studio. The project will deliver upland amenities, including community spaces and public areas connecting to Hudson River Park, and continue to function as a non-water-dependent use. Meanwhile, Pier 92 is city-owned, managed by NYCEDC, and currently inoperable.

Although not a City land use action, it should be noted that areas of the Land Use Study Area to the north, south, and east, are part of the Hudson River Park. In 1998, the Governor of New York signed into law the Hudson River Park Act, which designated a large portion of Manhattan's waterfront west of Route 9A between West 60<sup>th</sup> Street in the north and Battery Park City in the south as a park and established the Hudson River Park Trust. The Hudson River Park Trust oversees designing, building, operating, and maintaining the Hudson River Park. Changes to the park must be approved by the State Legislature through the introduction of amendments to the original law; since 1998, there have been six amendments to the Hudson River Park Act. The Manhattan Cruise Terminal (Piers 88, 90, and 92) and Pier 94 are not included as part of the Hudson River Park and, consequently, fall outside the boundaries of the associated Estuarine Sanctuary. All other piers along the Hudson River within the boundary of the park geography are included as part of the Hudson River Park.

### 3.6 Special Purpose Districts/Subdistricts

According to NYC's Zoning & Land Use Map (ZoLa), as of October 2025, there is one special-purpose district<sup>6</sup> within the Land Use Study Area:

- Special Clinton District (CL) - As noted when discussing the West Clinton rezoning, the tax lots directly east of Route 9A are included in the Special Clinton District. This district is aimed at strengthening and preserving the residential character of the community bordering Midtown, maintaining a broad mix of incomes and ensuring that the community is not adversely affected by new development. MCT is not located within this special purpose district, but portions of the Land Use Study Area to the east are located within the special purpose district.

---

<sup>6</sup> According to the New York City Department of City Planning, special purpose districts are designated to "achieve specific planning and urban design objectives in defined areas with unique characteristics. Special districts respond to specific conditions; each special district designated by the Commission stipulates zoning requirements and/or zoning incentives tailored to distinctive qualities that may not lend themselves to generalized zoning and standard development."

### **3.7 Proposed Development**

Proposed developments include projects that are under consideration but have not yet been adopted. The Department of Buildings Active Major Construction was searched for projects that have filed permits, and NYC Department of City Planning (NYCDP) Zoning Application Portal was searched for projects that have the potential to be completed by the analysis year. No new or projected developments were identified within the Study Area.

Although not a new development, Pier 94 directly to the north has filed alteration for certificate of occupancy (CO). No bulk or in-water alterations or changes are anticipated. As mentioned above, it is anticipated to begin operations in January 2026.

### **3.8 Land Use Summary**

The review of existing and past land use associated with the Land Use Study Area suggests that the proposed redevelopment of MCT and associated actions would not negatively affect the surrounding current or proposed land uses. The redeveloped MCT would continue to have transportation-related uses, consistent with the current use and compatible with neighboring uses. Additionally, the majority of the Land Use Study Area is publicly-owned land, so there can be comprehensive coordination between City departments. All future planned and proposed development would be compatible with the existing uses of the area, and would-be in-water construction that could have the potential to disturb the water are also consistent with current uses. The analysis and research herein have shown that no water-dependent uses currently exist or are proposed within the Land Use Study Area. Therefore, the proposed project would be consistent with current and future land uses in the Study Area.

## **4. Baseline of Existing Conditions**

### **4.1 Dredging and Bathymetry of the Hudson River Channel**

USACE is required to maintain the depths of the Federally Authorized Channel, as listed in Table 2-1 above. However, due to the natural ebb and flow of tides and other environmental factors, the Hudson River Channel generally maintains its navigable depth without requiring dredging or active maintenance by USACE. The agency's typical operations in the channel consist of hydrographic surveys, with the last survey having been conducted in April 2025, provided in Figure 4-1. The list of bathymetric surveys of the Hudson River Channel conducted by USACE within the last decade are listed below:

- April 2, 2025
- October 9, 2023
- December 20, 2022
- October 24, 2021
- November 8, 2020
- February 18, 2020

- February 13, 2019
- February 21, 2017
- January 6, 2016
- April 20, 2015

The minimum surveyed depths for each reach of the Hudson River Channel are summarized in Table 4-1 below, as taken from the most recent USACE Report of Channel Conditions, dated April 24, 2025. The main channel from the sea to the deepwater terminals in the Hudson River, including MCT and the associated project area, has a depth of approximately 45 feet.

**Table 4-1: Minimum Depths in Each Quarter Width of the Hudson River Channel Entering from Seaward, USACE Report of Channel Conditions, April 2025<sup>7</sup>**

Channel Reach	Authorized Depth (ft)	Minimum Depths (ft)			
		Left Outside	Left Inside	Right Inside	Right Outside
Reach A	45	35.4	43.9	42.9	43.6
Reach B	40	18.9	26.0	28.7	31.8
Reach C	40	41.1	38.6	29.1	12.0
Reach D	48	46.8	51.2	44.5	25.1
Reach E	40	14.4	32.2	43.0	45.4
Reach F	40	80% of Channel Width			
		20.4			
Reach G	30	15.6	31.6	34.6	37.0
Reach H	30	21.8	26.5	27.8	30.3
Reach I	30	11.8	19.7	22.2	25.1
Reach J	30	14.3	17.4	20.1	23.1
Reach K	30	15.9	19.8	22.0	24.2
Notes: All reported depths are the measured minimum depths relative to the Mean Lower Low Water (MLLW) datum.					

<sup>7</sup> US Army Corps of Engineers. *Report of Channel Conditions (for Channels 400 Feet Wide or Greater): Hudson River Channel, New York*. New York: US Army Corps of Engineers, April 24, 2025.

New York City Economic Development Corporation - Manhattan Cruise Terminal Master Plan  
Navigation Safety Risk Assessment - December 19, 2025

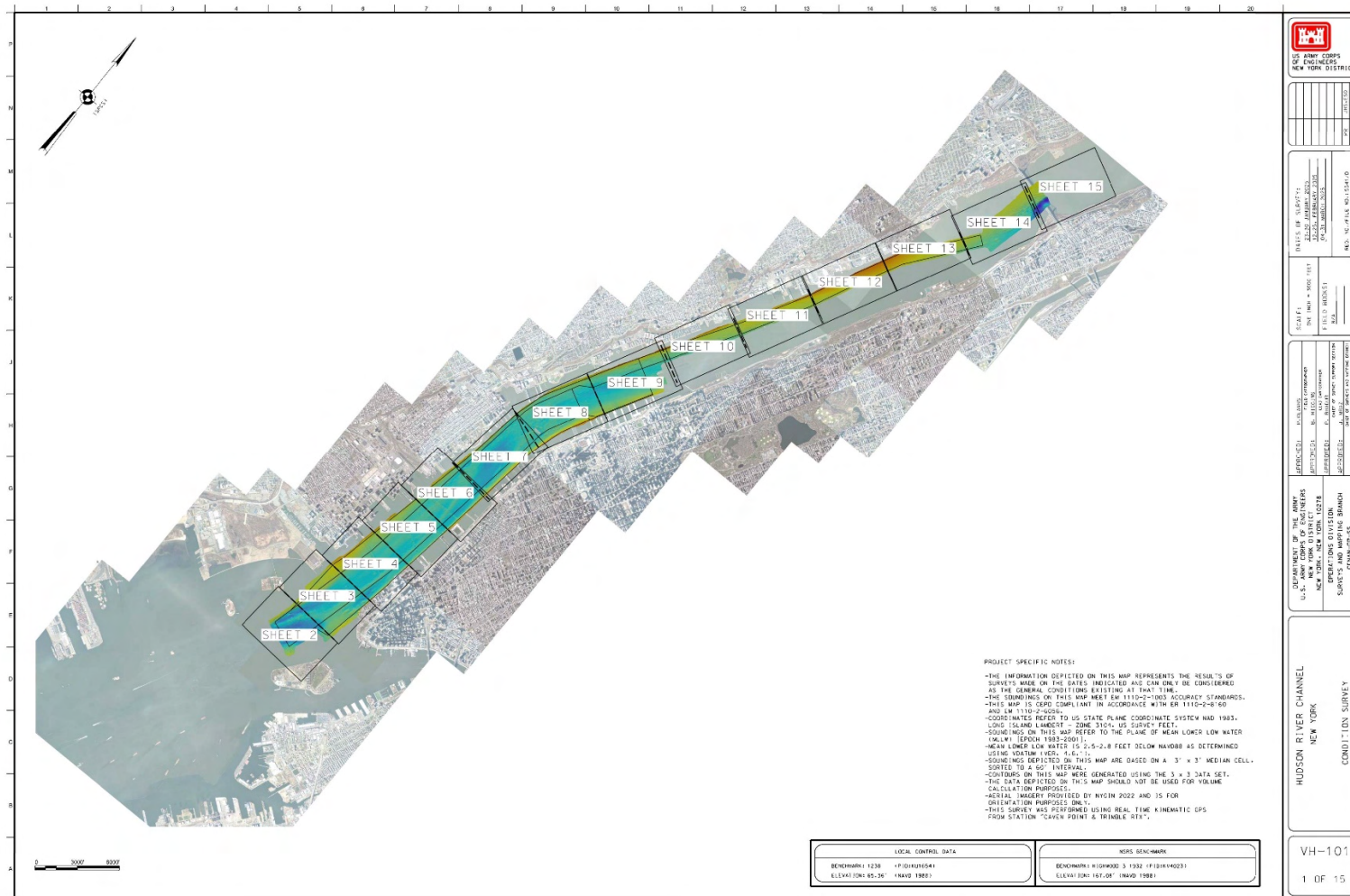
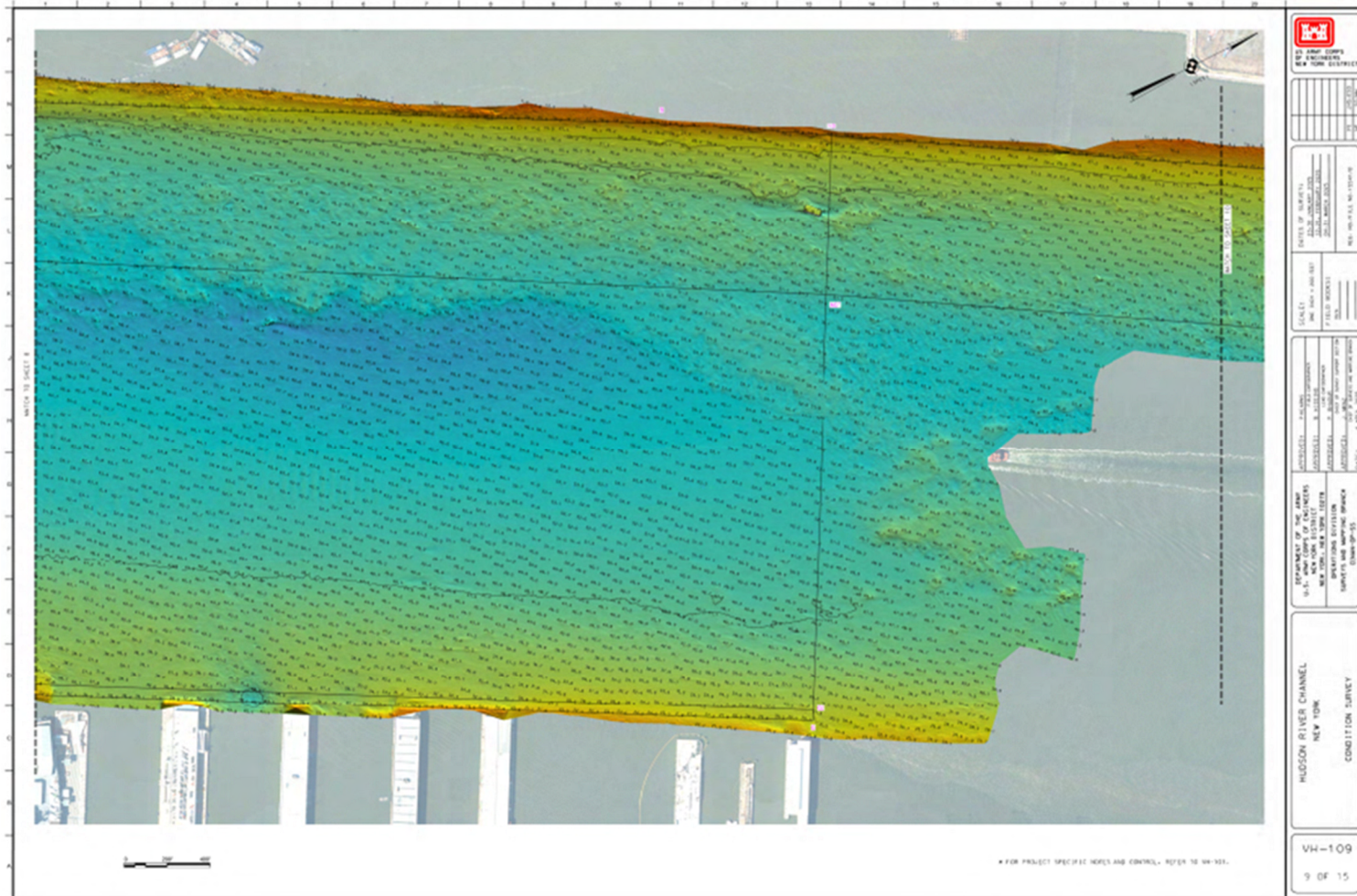


Figure 4-1: Hudson River Channel 2025 USACE Condition Survey Indicating Channel Limits



**Figure 4-2: Bathymetry Data in MCT Region of the Hudson River Channel as of April 2025 (Source: USACE)**

## 4.2 Dredging at MCT

NYCEDC conducts dredging in the MCT basin twice per year—in the spring and early fall—with dredging activities generally extending 61 meters (200 feet) past the pierhead line into the Federally Authorized Channel. Currently, the minimum dredge depth at Berths 1-3 (see Figure 1-2) is 11 meters (36 feet) to Mean Lower Low Water (MLLW) and 9.8 meters (32 feet) to MLLW at Berth 4, and current dredging protocols require an additional 0.6-meter (2-foot) over-dredge and a consistent slope of 3:1 with the pier faces. To allow the berthing of specific vessels, NYCEDC may increase dredge depth, and as recently as October 2022, the four berths were dredged to 38 feet below MLLW. This year’s spring dredge event was completed at the terminal in April 2025. The most recent dredge event occurred between August and September 2025. A summary of recent maintenance dredging activities and the latest bathymetry at the terminal are shown below.

**Table 4-2: Recent Maintenance Dredging at MCT and Associated Estimated Dredge Material Quantities**

Dredge Period	Post-Dredge Survey Report Date	Total Footprint Dredged (yd <sup>3</sup> )	Total Side Slope Dredged (yd <sup>3</sup> )	Total Amount Dredged (yd <sup>3</sup> )
Spring 2025	April 21, 2025	77,240	13,480	90,720
Fall 2024	October 16, 2024	160,483	7,273	167,756
Spring 2024	May 1, 2024	152,023	34,649	186,672
Fall 2023	September 8, 2023	87,467	9,490	96,957
Spring 2023	June 8, 2023	150,352	21,389	171,741
Fall 2022	October 27, 2022	167,439	15,017	182,456
Spring 2022	April 5, 2022	218,703	32,049	250,752

Note: Dredge volumes calculated by Hatch based on available pre- and post-dredge bathymetric surveys conducted by Rogers Surveying, PLLC and COWI Consulting Inc.

The current dredge footprint is approximately 11.6 hectares (28.7 acres). The proposed deauthorization area would extend into Reach F and Reach D, increasing NYCEDC’s dredge footprint by approximately 10.0 hectares (24.7 acres). Dredge spoils are typically brought to the Historic Area Remediation Site (HARS) for disposal.

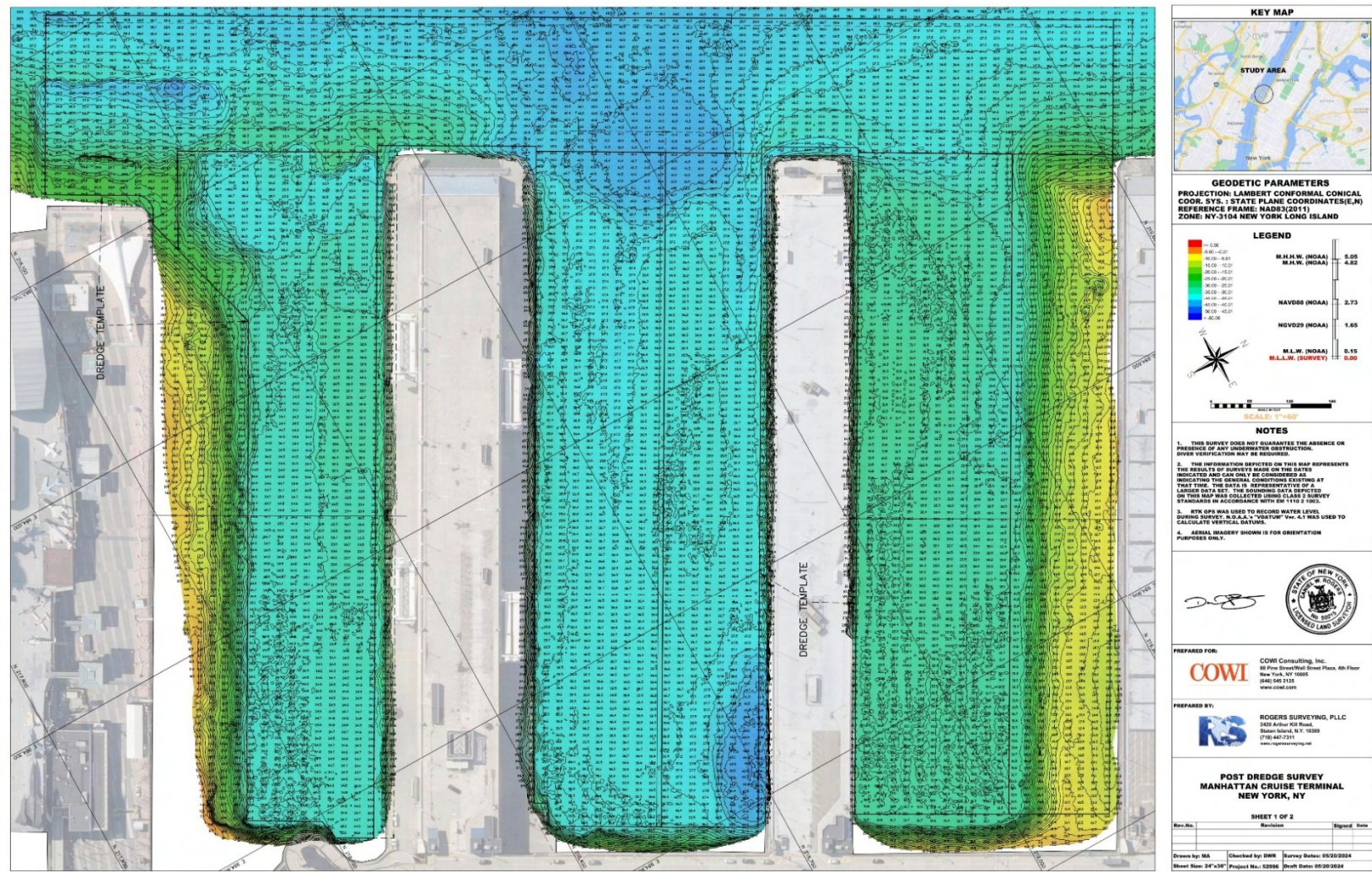


Figure 4-3: Spring 2024 Post-dredge Bathymetric Survey of MCT Basin

## **4.3 Physical Constraints**

### **4.3.1 Summary of Existing Structures**

The NOAA Electronic Navigation Charts (ENC) are used as a reference by pilots and captains and depict existing structures, Aids to Navigation, and other potential obstructions to avoid while transiting. The Hudson River ENC is provided in Figure 4-4, with Piers 86, 88, 90, and 92 surrounded by a magenta boundary. This boundary represents the USCG Maritime Security Zone (MSZ), which is a designated area with enhanced security measures to protect against threats and illegal activities. This MSZ is enforceable at all times through the oversight of MCT's facility security officer in coordination with the USCG.

A list of existing pier structures within the Study Area is provided in Table 4-3 below.

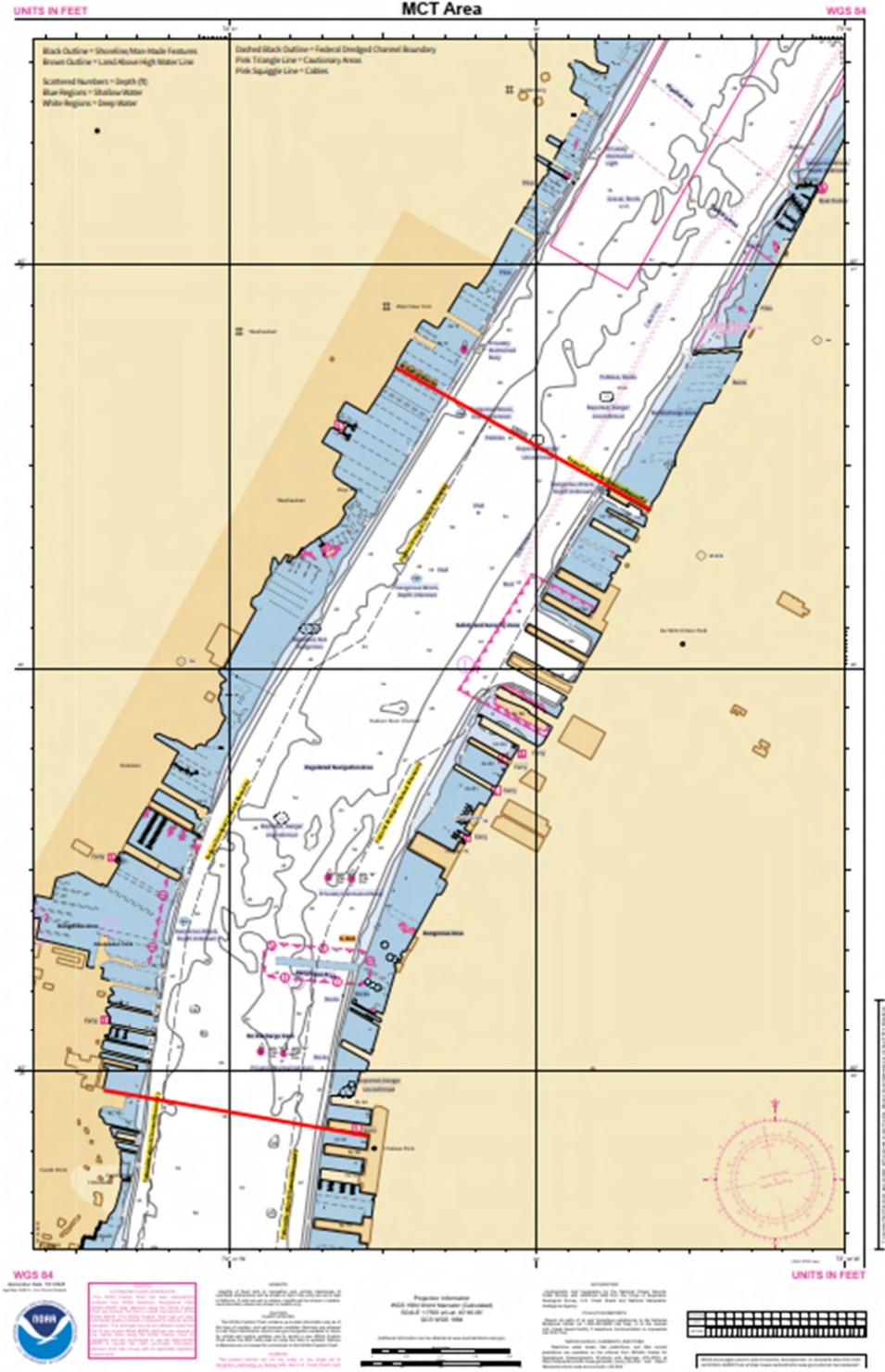


Figure 4-4: Electronic Navigation Chart of the Manhattan Cruise Terminal Area, Including the Study Area (Source: NOAA)

**Table 4-3: Summary of Existing Pier Structures within the Study Area**

<b>Pier</b>	<b>Latitude</b>	<b>Longitude</b>	<b>Listed Owner/Operator</b>	<b>Usage</b>
Pier 99	40°46'26.35"N	73°59'45.46"W	NYC Sanitation	Frequent tug & barge
Pier 98	40°46'23.17"N	73°59'46.41"W	ConEdison	Infrequent tug & barge
Pier 97	40°46'21.28"N	73°59'49.36"W	Hudson River Park Trust	None
Pier 96	40°46'16.86"N	73°59'46.01"W	Hudson River Park Trust	Human powered boating
Pier 94	40°46'13.87"N	73°59'56.10"W	Sunset Studios	None
Pier 86	40°45'56.49"N	74°0'7.78"W	Intrepid Museum	None
Pier 84	40°45'52.73"N	74°0'11.64"W	Manhattan Kayak	Human powered boating
Pier 83	40°45'49.23"N	74°0'13.34"W	Circle Line Cruises	None
Pier 81	40°45'45.19"N	74°0'16.12"W	Unknown	Boat Pier
Pier 79	40°45'38.48"N	74°0'15.15"W	NY Waterway	Ferry Terminal
Pier 78	40°45'35.61"N	74°0'15.66"W	Hudson River Park Trust	Park
Pier 76	40°45'33.98"N	74°0'24.74"W	Unknown	Park
Helipad 6 (W 30 <sup>th</sup> St Heliport)	40°45'21.23"N	74°0'27.01"W	Blade Helicopters	Helicopter Terminal
Pier 66	40°45'10.55"N	74°0'35.89"W	FDNY	Fire Boat Pier
Pier 64	40°45'4.12"N	74° 0'38.43"W	Unknown	Park
Pier 62	40°44'55.30"N	74°0'40.62"W	Unknown	Park
Pier 61	40°44'51.62"N	74°0'41.47"W	Chelsea Piers	Boat Pier
Port Imperial, NJ Ferry Terminal	40°46'33.99"N	74°0'35.87"W	NY Waterway	Ferry Terminal
NY Waterway Yard	40°46'13.11"N	74°0'41.10"W	NY Waterway	Ferry Yard
Weehawken Pier	40°45'43.72"N	74° 1'6.84"W	Unknown	Park
Weehawken Chart House Pier	40°45'38.01"N	74° 1'4.65"W	Unknown	Restaurant
Weehawken World Event Yacht	40°45'33.97"N	74° 1'6.10"W	Unknown	Boat Pier and Apartment Complex
Weehawken Riva Pointe	40°45'27.71"N	74° 1'10.47"W	Unknown	Apartment Complex
Hoboken 15th St. Pier	40°45'11.14"N	74° 1'14.60"W	Unknown	None
Hoboken 14th St. Pier	40°45'7.81"N	74° 1'14.80"W	Unknown	Ferry Terminal and Passenger Cruise Terminal
Hoboken Shipyard Marina	40°45'4.52"N	74° 1'15.69"W	Unknown	Recreational Boat Marina

Pier	Latitude	Longitude	Listed Owner/Operator	Usage
Hoboken Pier 11	40°45'1.02"N	74°1'15.94"W	Weeks Marine	None
Hoboken Maxwell Place Park	40°44'59.83"N	74°1'18.97"W	Unknown	Park

## 4.3.2 Infrastructure Programs

### 4.3.2.1 Lincoln Tunnel

The Lincoln Tunnel runs between New Jersey and Manhattan, generally parallel to Pier 79. The tunnel is about 126 meters (415 feet) wide and is located approximately 701 meters (2,300 feet) from the southern end of Pier 88 at MCT, within the bounds of the Federally Authorized Channel. While it is in the general vicinity of MCT, the seabed is maintained at a depth of at least 12.2 meters (40 feet) below MLLW and therefore does not pose a major navigational risk to transiting vessels.

### 4.3.2.2 The Hudson Project

The Hudson Project consists of a 345 kV AC buried, submarine power cable system which supplies electric power from the Bergen Generating Station in Ridgefield, New Jersey to Consolidated Edison's (ConEd) substation at West 49<sup>th</sup> Street in Manhattan. The cable is buried 3 meters (10 feet) below the seabed in non-navigable sections of the waterway and 4.6 meters (15 feet) below the seabed in navigable sections.<sup>8</sup> The cable runs parallel with the Hudson River, along the eastern side, and turns towards Manhattan midway between Piers 92 and 94. It is depicted in Figure 4-4 as a pink zig-zag heading north from between Piers 92 and 94. For current and future cruise ship operations at MCT and vessel traffic navigation around MCT associated with the Blue Highway initiative or tugs and other vessels planning to moor in this area, the cable does not pose a risk as it is buried well-beneath the mudline of the navigable and un-navigable channel.

### 4.3.2.3 George Washington and Verrazano Bridges

The closest bridge to the terminal, the George Washington Bridge to the north, does not affect operations at the terminal as large cruise vessels do not transit north of MCT. The Verrazano Bridge at the entrance to New York's Lower Harbor provides the upper limit air draft for ships transiting in New York Harbor and to MCT but does not pose a significant constraint to maneuvering or navigation at the terminal.

### 4.3.2.4 Hudson River Ground Stabilization Program

The Hudson River Ground Stabilization Gateway Program (HRGS) involves reinforcing the earth on the Manhattan shoreline to support the construction of an inter-state tunnel from New York to New Jersey and is planned for completion in 2027.<sup>9</sup> At the time of this NSRA, a 183-meter (600-foot) cofferdam and several spud barges were staged towards the center of

<sup>8</sup> Hudson Project. *Project Description*. Accessed October 10, 2025. <https://hudsonproject.com/project/description/>.

<sup>9</sup> Gateway Development Commission. *Hudson River Ground Stabilization Project. Gateway Program*. Accessed October 8, 2025. <https://www.gatewayprogram.org/hudson-river-ground-stabilization-project.html>.

the Hudson River Channel, generally between Pier 66 in Manhattan and 1600 Park in Weehawken, NJ. The cofferdam and associated barges have a buffer zone implemented for cruise ships and other vessels to route around as the project progresses across the river. The temporary structure is marked with white flashing lights at 4 second intervals at the corners and at every 30-foot length of the vessel. The structure is also marked on the NOAA ENC's. There have been no recordable incidents associated with this project. The HRGS team works with Vessel Traffic Services (VTS) to issue warnings and Notices to Mariners, as required. The location of the HRGS cofferdam at the time this report was issued and associated aids to navigation are depicted in Table 4-4.

#### 4.3.2.5 *Miscellaneous Projects*

Other infrastructure projects in the project area include pile repairs at Pier 94 from June 2025 through June 2027 and marine construction work north of Pier 66 from September 2025 through April 2026. Both of these projects are noted in the USCG's Notices to Mariners and will likely not impact navigation safety at MCT.<sup>10</sup> Based on a search of public records, other than those listed above, there are no other infrastructure projects identified in the Study Area that impact navigation, including a survey of possible overhead electrical lines, undersea pipelines, or civil projects.

#### 4.3.3 *Environmental Conditions*

New York City, an area exceeding 300 square statute miles, is located on the Atlantic coastal plain at the mouth of the Hudson River. The terrain is predominantly flat, interwoven with a network of waterways, with Manhattan namely bordered by the Harlem River to the north, the East River to the east and the Hudson River to the west. Although the city lies close to the ocean and is surrounded by bays and rivers, its climate more closely resembles a continental type than a maritime one. This modified continental climate is largely due to prevailing weather systems that typically move in from the west rather than from the Atlantic to the east.

The lower Hudson River is a tidal estuary, with tidal influence extending as far as the Federal Dam in Troy, New York. There are about two high tides and two low tides per day. As the tide floods, the current moves northward, parallel with the channel, and as the tide ebbs, the current moves southward. From the NOAA ENC's, the riverbed around the Hudson River and within the Study Area generally consists of mud.<sup>11</sup>

The National Oceanic and Atmospheric Administration's (NOAA) records of tidal currents, surveyed at Pier 92 in 2024, indicate that the maximum annual flood current was 3.0 knots and that the maximum annual ebb current was 3.7 knots.<sup>12</sup> In certain years, it has been reported that ebb currents can run up to 5.0 knots due to rain or snow melt.<sup>13</sup>

<sup>10</sup> United States Coast Guard. *Local Notice to Mariners, District 1*. No. 0141-25. October 8, 2025. <https://www.navcen.uscg.gov/msi>.

<sup>11</sup> US Geological Survey. *usSEABED: US Sediment Data*. Coastal and Marine Geology Data System. Accessed October 14, 2025. <https://cmgds.marine.usgs.gov/usseabed/>.

<sup>12</sup> National Oceanic and Atmospheric Administration. *NOAA Tidal Current Predictions: Hudson River, Pier 92, 2024*.

<sup>13</sup> Bermello Ajamil & Partners, Architects and Engineers Inc. *MCT Pier 90 North Apron STAR Center Vessel Simulations*. Memorandum prepared for Ports America, August 30, 2023.

Between November and April, the dominant wind direction is from the northwest, while southwesterly winds prevail during the rest of the year. Generally, winds from these directions reach a typical maximum speed of approximately 25 knots. Gale-force winds, reaching approximate speeds of 35 knots or more, most often originate from the northwest.

These wind and current conditions represent the typical upper envelope of patterns for maneuvering and navigating on the Hudson, and are consistent with the data observed and feedback from captains and pilots transiting the river. While more extreme conditions are possible in the area, vessels experiencing extreme conditions will follow standard operating procedures for navigating and maneuvering, such as anchoring in New York Harbor or requesting assist tugs, and will follow USCG and other emergency procedures as required.

Ice also plays a role in navigation on the Hudson River. The USCG has established a regulated navigation area on the navigable waters of the Hudson south of the Troy Locks, effective during certain ice conditions. In general, the channel around MCT does not freeze over, and any ice that does form is typically well broken up by tugs and general traffic. Freshwater ice is brought down the Hudson River in large floes during periods of thaws or winter freshets. Under strong winds, the slips on the exposed side of the channel become packed with drift ice, causing difficulty for vessels maneuvering in the slip. During extremely severe winters, navigation may be impaired or curtailed for only short periods of time. Although ice does not typically restrict navigation within the Hudson River Channel in the Study Area, there is historical precedence for ice accumulation in the berths at MCT. If the piers at MCT are extended further into the channel, ice-related impacts may become more significant in the future.

#### **4.3.4 Recorded Wrecks and Obstructions**

USACE, USCG, and NOAA record and maintain detailed survey data and associated records listing reported wrecks and underwater obstructions, including shoals and increasingly shallow areas. USACE New York District provides periodic hydrographic surveys of the federal channels and issue regular Survey and Controlling Depth reports. Historically, Automated Wreck and Obstruction Information System (AWOIS) and USACE Hydrographic Surveys indicate there are multiple obstructions and wrecks in the Lower Hudson River. None of these reported obstructions have proven to be of a hazardous nature to large commercial vessels or cruise ships. Based on present published hydrographic data, there are no recorded wrecks or obstructions in the area that would threaten safe passage.

Residual timber piles from removed piers occur in places between the bulkhead and pierhead lines. Former Piers 68 and 69, just north of Pier 66, have documented, in-water obstructions and are planned for removal in connection with the Hudson Tunnel Gateway Program. There are also residual timber piles between Piers 92 and 94, but they do not pose a hazard to cruise ships maneuvering at the terminal. The proposed future layout avoids the timber piles in this area entirely.

## 4.4 Aids to Navigation

New York Harbor is the principal entrance by water to New York City and the surrounding ports. The harbor is divided by The Narrows into the Lower Bay and the Upper Bay. The Battery, the southern tip of Manhattan, is at the junction of the East River and the Hudson River. Various operational and physical aids to navigation are available to mariners transiting in New York Harbor, including GPS, AIS, buoys, beacons, and lights. These aids are strategically positioned and maintained to ensure safe and efficient vessel movement through the harbor's complex and heavily trafficked waterways.

### 4.4.1 Operational Aids to Navigation

#### 4.4.1.1 Electronic Navigation Charts

Ships transiting the Hudson River use ENC's to plan their routes, understand the physical aids to navigation, and anticipate hazards in the river. These ENC's are updated on a consistent basis by the US Office of Coast Survey based on Notices to Mariners, installation of temporary aids to navigation, and other obstructions that may be present. An ENC for the Hudson River Channel, shown in Figure 4-4, was used in this assessment to understand the regulated and unregulated navigable waters and specific risks present in the project area.

#### 4.4.1.2 Vessel Traffic Service

Vessel Traffic Service (VTS) New York was established to monitor and manage vessel traffic, prevent groundings and other casualties, and to promote the safety and environmental security of the waterway resources of the Port of New York & New Jersey. VTS New York is operated by USCG Sector New York and encompasses the navigable waters of New York Harbor, including the approaches to MCT, under 33 CFR §161.25. VTS has the ability to communicate with vessels transiting the Hudson River via Very High Frequency (VHF) radio and provides real-time traffic information, navigational assistance, and traffic organization directives, when necessary, to vessels transiting the Hudson.

Under 33 CFR §161.18, certain vessels are required to participate in the Vessel Movement Reporting System (VMRS), which involves reporting position, destination, scheduling, and other key details to VTS New York for regulatory compliance and vessel traffic planning support. VTS and VMRS are used in conjunction to ensure that vessels are accounted for and their movements are predictable and safe.

### 4.4.2 Physical Aids to Navigation

Physical aids to navigation may include buoys, beacons, daymarks, lighthouses, fog signals, radar reflectors, and lights. The USCG Light List and Local Notices to Mariners<sup>14</sup> for District 1, which include the Hudson River, was referenced in identifying detailed information regarding the characteristics of light structures, buoys, sound signals, and electronic aids to navigation in the Study Area. In the Study Area, several private lights have been identified and are listed

---

<sup>14</sup> U.S. Coast Guard. *Local Notice to Mariners for District 1, Week 42, October 15, 2025*. U.S. Department of Homeland Security, 2025. <https://www.navcen.uscg.gov/msi>.

below in Table 4-4, all of which are related to the HRGS.<sup>15</sup> As the HRGS project is set to be completed in 2027, these aids to navigation will likely be removed prior to the redeveloped MCT coming online. There do not appear to be any other Aids to Navigation in the study area. A diagram of the physical aids to navigation within the study area is included as Figure 4-5.

**Table 4-4: List of Physical Aids to Navigation on the Hudson River within the Study Area**

List Number	Name	Latitude	Longitude	Structure	Description
37663	Hudson River Cofferdam Lighted Hazard Buoy A	40°45'28.7 2"N	074°00'40.7 3"W	White with Orange Bands	Lighted Buoy
37663.1	Hudson River Cofferdam Lighted Hazard Buoy B	40°45'28.6 8"N	074°00'36.1 8"W	White with Orange Bands	Lighted Buoy
37663.2	Hudson River Cofferdam Lighted Hazard Buoy C	40°45'02.7 3"N	074°00'53.9 6"W	White with Orange Bands	Lighted Buoy
37663.3	Hudson River Cofferdam Lighted Hazard Buoy D	40°45'02.6 9"N	074°00'49.4 1"W	White with Orange Bands	Lighted Buoy

<sup>15</sup> US Coast Guard Navigation Center, "Maritime Safety Information," *US Coast Guard*, <https://www.navcen.uscg.gov/msi> (accessed October 9, 2025).

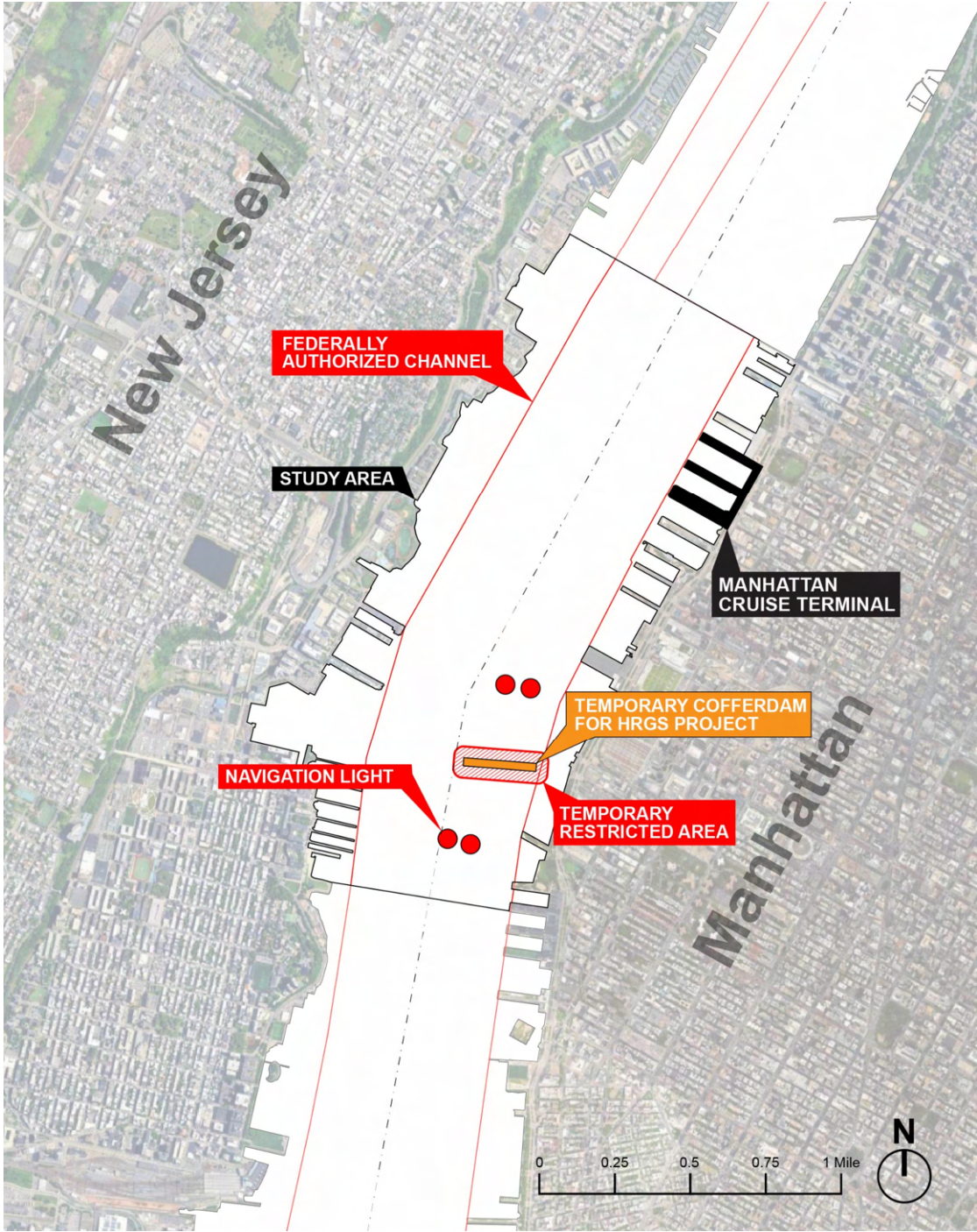


Figure 4-5: Aids to Navigation in the Study Area as of January 2, 2025, with the Full Restricted Area of the HRGS Project Depicted<sup>16</sup>

<sup>16</sup> US Coast Guard Navigation Center, "Maritime Safety Information," *US Coast Guard*, <https://www.navcen.uscg.gov/msi> (accessed October 9, 2025).

### **4.4.3 Anchorages**

There are no specific anchorage areas within the Study Area. Anchoring in this area of the channel would only be as required during an emergency in which a vessel was rendered uncontrollable and would only be attempted as a critical, last option. Ships are advised to coordinate anchoring needs via USCG VTS and follow directions for movement from the Captain of the Port (COTP).

For this study, several anchorages north of MCT were identified for reference and are illustrated in Figure 4-6. These anchorages would not be affected by deauthorization of a portion of the Federally Authorized Channel in the Study Area.

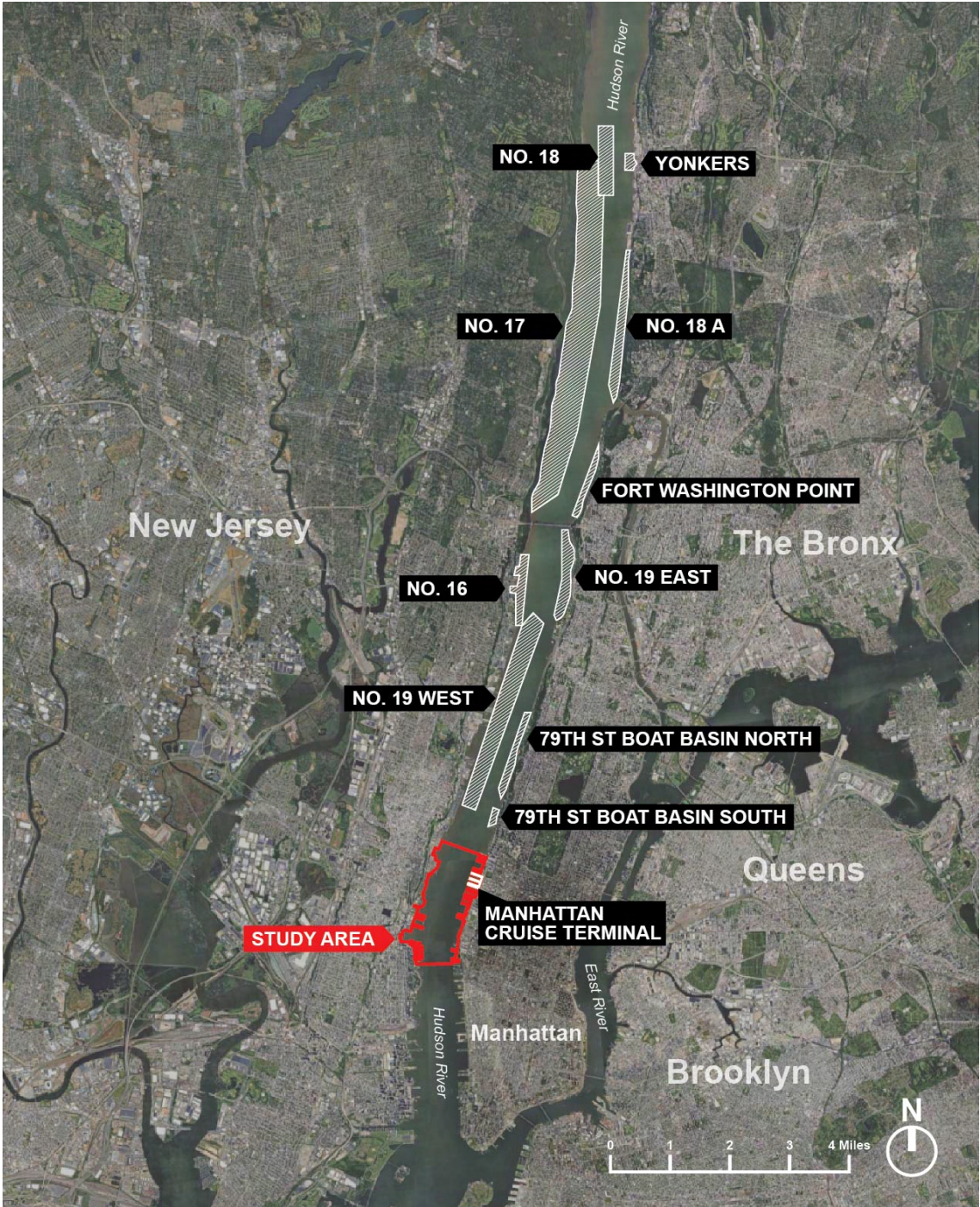


Figure 4-6: Anchorage Areas in the General Vicinity of the Study Area<sup>17</sup>

<sup>17</sup> US Government Publishing Office. *Electronic Code of Federal Regulations: Title 33—Navigation and Navigable Waters, Chapter I, Subchapter I, Part 110—Anchorage Regulations*. Last amended August 15, 2025. Accessed October 12, 2025. <https://www.ecfr.gov/current/title-33/chapter-I/subchapter-I/part-110>.

## 5. Stakeholder Consultation and Practical Mitigation Measures

As a key aspect of this NSRA and as a requirement for the WRDA process, a series of stakeholder engagement meetings were held with commercial and human-powered harbor users and relevant City Agencies to understand each group's current operations on the Hudson River proximate to MCT, the potential impacts associated with the Proposed Project and channel deauthorization, and any potential mitigations relating to the identified risks.

This engagement was generally conducted through Hazard Identification (HAZID) workshops. In these workshops, NYCEDC and Hatch provided a background of the MCT redevelopment proposal, in addition to the WRDA and NSRA process. Feedback was then solicited from stakeholders through the form of a structured discussion guided by pre-developed questionnaires to identify specific hazards, risks, and practical mitigation measures. Each participant in the workshops wrote down risks, hazards, and mitigation measures, which were then collected and added to a Risk Register for the workshop. An overall, compiled Risk Register, encompassing all the workshops, is included in Appendix A. The complete meeting minutes associated with each of the workshops is included in Appendix B. Stakeholders were invited to participate in the five distinct HAZID workshops conducted throughout the project. A list of stakeholders engaged and whether they attended the HAZID sessions is provided under each of the below sections.

Stakeholders were also invited to attend a hybrid session on December 8, 2025 where the results of the NSRA were presented, including discussion of the project impact analysis, SIREN assessment, and Desktop Navigation Simulations, and were allowed an opportunity to provide feedback. Representatives from the commercial maritime industry, ferry operators, City agencies, and human powered boaters were all in attendance, with 65 people in total attending both in-person and virtually.

In parallel, NYCEDC maintained consistent communication with USCG and USACE, through a series of independent briefings. Additionally, NYCEDC consulted with cruise line partners to ensure the methodology and results of the NSRA aligned with industry expectations.

### 5.1 Pilots, Deep Draft, Tug and Barge

An in-person HAZID Workshop was held with ship pilots and commercial users on September 17, 2025 at the Sandy Hook Pilots offices in Staten Island, New York. The list of invited stakeholders is included below, with those in attendance marked with an asterisk (\*):

- Sandy Hook Pilots Association\*
- The Maritime Association of the Port of New York and New Jersey (MAPONY/NJ)\*
- Harbor Safety, Navigation and Operations Committee (HOPS) Tow Boat & Harbor Carriers of the Port of NY/NJ\*
- Donjon Marine Corporation\*
- Moran Towing Corporation\*

- Metro Pilots\*
- McAllister Towing\*
- Vane Brothers\*

Overall, attendees of this workshop were in support of the Proposed Project. They noted that increase in commercial vessel traffic is generally good for their businesses. The main risks that attendees noted were associated with vessel traffic potentially being exposed to increased current speeds in the center of the navigable channel and interaction with human powered vessel users. Though, they suggested that there are likely several engineering and technological adaptations and approaches that could mitigate these risks. Most attendees suggested that safety on the river and flow of traffic will likely be unchanged as a result of the redevelopment.

The risks and mitigations collected during the workshop are summarized below in Table 5-1.

**Table 5-1: Risk Register from Pilots, Deep Draft, and Tug and Barge HAZID Workshop**

Risk ID	Originator	Risk Description	Risk Mitigation
1	Jim Mahlman, Sandy Hook Pilots Jon Miller - Metro Pilots	Coming out into the channel at strength of current can be difficult when maneuvering cruise ship	Real-time current sensor at end of pier or on a buoy at the end of the dolphin. Optimization of vessel schedules within reason to reduce interaction with strong currents during departure.
2	Russ Henchman - Harbor Pilots of NYNJ	With the piers located farther out, there's a concern that towing vessels may continue operating as they currently do—providing only brief assistance—rather than remaining made fast for longer durations. This could pose challenges for maneuvering vessels that require sustained towing support while approaching the berths.	Tug support upon approach. Optimization of vessel schedules within reason to reduce interaction with strong currents during maneuvers.
3	Brian Rau - Vane Brothers	Losing pivot point on Pier 90 if demolished, particularly with larger vessels and larger stems, may increase the potential to run out of room between cruise ships during maneuvering.	Schedule barge movements carefully. Maintain safe separation buffers. Utilize the increased basin space once constructed.
4	Jon Miller - Metro Pilots	How will the current change as a result of the infrastructure change?	Assessment of hydrodynamics of the proposed piers and their affect on the channel currents in future studies. Detailed hydrodynamic modelling and sedimentation in future studies.
5	Brian Rau - Vane Brothers	Current will continue to run through mooring dolphins and may cause unpredictable eddies and currents.	Assessment of hydrodynamics of the proposed piers and their affect on the waters within MCT.

Risk ID	Originator	Risk Description	Risk Mitigation
6	Jon Miller - Metro Pilots	Increased prop wash may affect construction, shoaling, and scouring, particularly with those ships that moor at MCT for a long period of time.	Propwash induced current and scour assessment in future studies.
7	Brian Henry - Donjon	Scows are around 135' and there should be enough space at MCT, but coming out into the current could be difficult to maneuver.	Potential need for larger tugs to combat current speed.
8	Nathan Hauser - Moran	There is a risk of a support vessel (tug) losing power and being more exposed to vessel traffic and environmental factors since it is further into the Hudson. There is a risk that the vessels are more susceptible to emergency scenarios as they will be in the middle of the channel rather than tucked away closer to MCT.	Use larger or more tugs. Schedule movements during lower current periods, as possible.
9	Jon Miller - Metro Pilots Brian Rau - Vane Nathan Hauser - Moran	Usage of Hudson River area around MCT by human powered boaters. As the plan for the piers is to extend further into the channel, the human powered boaters will be more exposed to faster currents and potentially more unsafe conditions	Standby emergency response vessel during arrival and departure of cruise vessels. Safety vessel or standby vessel to collect people and human powered vessels in emergency scenarios. Dredge operations has a crew boat at all times for safety. Increased signage, awareness, and best practice instructions for human powered boaters at their origin and destination piers/docks.
10	Russ Henchman - Harbor Pilots of NYNJ	Contending with current for vessels responding to emergency scenarios.	increase on site emergency response capabilities with redeveloped terminal plan.
11	Jon Miller - Metro Pilots Jim Mahlman - Sandy Hook Pilots Brian Rau - Vane	Vessels may use South Pier dolphins as a pivot point during future operations. There is a risk that if the pier is not designed for this type of operation. As a result, the vessels could be damaged or cause damage to the infrastructure.	Take into account pivoting forces on South Pier dolphin for vessel entering into southern berth and apply appropriate fendering.
12	Brian Rau - Vane Brothers	Pier 90 is currently used as a bail out point during maneuvering of barges and removal of this pier may cause risk of contact incidents where there isn't a point for barge's to maneuver off of.	Additional tugs may be required for maneuvering barges into position at redesigned MCT.
13	Jon Miller - Metro Pilots	There is the potential that the piers are being overbuilt and over-extended into the channel, as there is sufficient mooring to	Cruise ships need the additional pier infrastructure for landside support and access to aft hatches, particularly for the larger vessels.

Risk ID	Originator	Risk Description	Risk Mitigation
		accommodate the cruise ships currently.	Also, cruise ships currently have issues with mooring line leads.
14	Russ Henchman - Harbor Pilots of NYNJ	Challenges with the extreme beams of ships overhanging onto the terminal areas and further constrict the space for support vessels to maneuver.	The majority of cruise ships expected in the future are already frequenting MCT, and there will be more space inside the main basin once the expansion is completed. Vessel-specific approach planning and increased tug support may be needed for largest vessels.
15	Steve Lyman - MAPONY	The Hudson River is shallower on the NJ side, so extending the piers further into the Hudson will force cruise ship and other vessel traffic towards the NJ side and may increase potential risk of groundings.	The spatial extent of vessel route offsets are not expected to drive deep draft vessels beyond a limit where there is sufficient under keel clearance in the main channel, or appreciably change route patterns in shallow areas on the New Jersey side. Updated bathymetry survey and/or monitoring and increased pilot awareness through NTMs.

## 5.2 City Agencies

An in-person HAZID Workshop was held with New York City agencies on September 29, 2025 at the NYCEDC offices at One Liberty Plaza in Manhattan, New York. The list of invited stakeholders is included below, with those in attendance marked with an asterisk (\*):

- Fire Department of the City of New York (FDNY)\*
- New York Police Department (NYPD) Harbor Unit\*
- New York City Department of Environmental Conservation (NYCDEP)\*
- New York City Parks Marine Division\*

The main risks that attendees identified were related to the potential for increased ferry traffic in the area causing congestion in the navigable waterway and site access during emergency situations. However, the attendees noted that the overall increase to emergency response would be in the region of 30 seconds as a result of the Proposed Project. The agency representatives provided several potential mitigation measures to address risks, such as additional aids to navigation and providing consistent updates to agencies during construction periods. In general, attendees suggested that safety on the river and flow of traffic will likely be unchanged as a result of the redevelopment of MCT.

The risks and mitigations collected during the workshop are summarized below in Table 5-2.

**Table 5-2: Risk Register from City Agencies HAZID Workshop**

Risk ID	Originator	Risk Description	Risk Mitigation
1	New York Fire Department	Increased scheduled ferry traffic over time may cause issues for emergency response vessels accessing the terminal in an emergency.	Increased coordination between ferry schedules and emergency operations.
2	New York Parks New York Police Department	Commercial vessel traffic interaction with human-powered vessel traffic has the increased risk of casualties and collisions.	Stakeholder outreach; dedicated kayak zones; warnings during commercial and cruise ship arrivals, additional communication measures between kayakers and commercial vessel users through marine radios.
3	New York Parks	With the present pier configurations, upstream piers are able to break ice flows. There is an increased risk of vessels colliding with bergs with the new pier configuration that extends further into the channel.	Increased ice monitoring; schedule movements to avoid ice flows; timely ice-breaking measures.
4	NYC Department of Environmental Protection NYPD FDNY	Increased number of construction vessels at the terminal during construction activities will increase risk of collisions, allisions, and groundings	VTS will need to provide updates regarding vessel traffic, surveys, diving at the terminals, with potential to designate specific person to control area. USCG will have to provide Local Notices to Mariners. NYPD also suggested creating "frozen zones" while the project is ongoing.
5	NYPD	In the summer months particularly, jet ski traffic increases considerably.	Stakeholder outreach with jet ski clubs and businesses, as well as Jersey Marine Task Force, to discuss mitigation measures.
6	NYC Department of Environmental Protection	Extending the piers into the channel poses an increased risk for allisions.	Lighting at the ends of the piers, additional aids to navigation, signage on dolphins, warnings to keep public out.
7	FDNY	With longer piers, there is an increased risk of allision at the terminal.	Enforcement of an exclusion zone around the extended piers to have background traffic avoid it at a specified offset distance.
8	FDNY	FDNY needs access to water supply during construction phasing and after construction is completed during emergencies.	Ensure that there are locations for the "Three Forty Three" to tie up, and a dry pipe standpipe system at the piers with manifold will allow FDNY to supply piers with water.
9	FDNY	If there is an emergency on the vessel or at the terminal, there is an increased risk associated with evacuating people.	Emergency response plans/drills, designated evacuation routes, dedicated safety vessels standby.

Risk ID	Originator	Risk Description	Risk Mitigation
10	NYC Department of Environmental Protection	Without increased vessel security waterside, there likely will be an increased risk of incidents and breaches.	Security zone enforcement, with potential engagement of port authority police department.

### 5.3 Ferry and Excursion Operators

An in-person HAZID Workshop was held with ferry and excursion operators on October 1, 2025 at the NYCEDC offices at One Liberty Plaza in Manhattan, New York. The list of invited stakeholders is included below, with those in attendance marked with an asterisk (\*):

- NY Waterway\*
- New York City Ferry\*
- Hornblower Corporation\*
- New York Cruise Lines

Attendees were generally in broad support of the Proposed Project. NY Waterway noted that they provide ferry services and excursion experiences for MCT cruise passengers. The main risk attendees identified were related to the potential of delays or other impacts to vessel services as a result of increased cruise traffic. To mitigate this, it was suggested that the ferry operators be provided the cruise ship schedule in advance to improve coordination and reduce risks of delays or collisions. It was also suggested that with the potential increase in dredging, appropriate measures be put in place to ensure dredge spoils are controlled.

The risks and mitigations collected during the workshop are summarized below in Table 5-3.

**Table 5-3: Risk Register from Ferry Operator HAZID Workshop**

Risk ID	Originator	Risk Description	Risk Mitigation
1	NY Waterway	Future pier and breakwater at Weehawken Yard to extend 100/200 feet off of the New Jersey pierhead line, which may further encroach on the navigable channel and impact vessel traffic.	Future analyses related to the Proposed Project should include how the NY Waterway yard redevelopment will also affect vessel operations on the Hudson.
2	NY Waterway	Currently, NY Waterway doesn't receive arrival or departure schedules, which causes increased risk of collision since they can't plan efficiently.	Suggested that VTS provide supplemental broadcasts with notices of arrival and departure of cruise ships.
3	NY Waterway	Risk to visibility that may increase casualties.	VTS currently provides adequate updates.

Risk ID	Originator	Risk Description	Risk Mitigation
4	NY Waterway	Impact of construction phasing on vessel traffic may increase risk of allisions or collisions.	NY Waterway suggested VTS to implement slow bell in area, and they also suggested that USCG could implement public outreach through their inspectors to inspected vessels regarding input to the NSRA.

## 5.4 Human Powered Boaters

A hybrid virtual/in-person HAZID Workshop was held with human powered vessel operators on October 14, 2025 at the NYCEDC offices at One Liberty Plaza in Manhattan, New York. The list of invited stakeholders is included below, with those attending in-person marked with an asterisk (\*) and those attending virtually marked with a double asterisk (\*\*):

- New York Outrigger\*
- HOPs Education Subcommittee\*
- Downtown Boathouse, Inc\*
- Outside New York\*
- Manhattan Kayak Co\*\*
- New York City Water Trail Association\*\*
- Hudson River Community Sailing (HRCS)
- Manhattan Community Boathouse
- Manhattan Sailing School
- Manhattan Community Board 4

Human powered boater representatives were generally neither in support nor against the Proposed Project. Attendees were not specifically concerned regarding cruise ship traffic, as they typically have good experience communicating with cruise operators. The main concerns that human powered boaters voiced were related to potentially being routed closer to the center of the navigable channel, where the current speed is faster, and the potential for increased interaction with ferry and tug traffic. Attendees suggested that developing a dialogue with commercial operators, ferry operators, and USCG would assist in reducing risks.

The risks and mitigations collected during the workshop are summarized below in Table 5-4.

**Table 5-4: Risk Register from Human Powered Boaters HAZID Workshop**

Risk ID	Originator	Risk Description	Risk Mitigation
1	NY Outrigger	The potential for extended piers and increased boundary of the USCG security zone will likely cause paddlers to have to stay closer to the center of the channel and away from the more protected waters of shore.	Rerouting of kayakers away from MCT.
2	NY Outrigger	Fast moving boats who don't communicate adequately via VHF.	Streamline communication via VHF radio between all vessel operators.
3	HOPS Education Subcommittee	Lack of lighting on extended dolphins and piers.	Installation of lighting on dolphins for redeveloped pier structure to ensure that casualties are kept at a minimum.
4	NY Outrigger	The mooring dolphins extending into the faster currents towards the center of the channel have the potential to create a hydrodynamic straining affect that can potentially cause harm to human powered boaters transiting in the area.	It is recommended that a hydrodynamic analysis of the mooring dolphins and pier infrastructure be conducted in the future to understand the effect these structures will have on the water moving past MCT. Future design of these structures should consider the hydrodynamic analysis to ensure that unpredictable currents and straining affects are reduced.

## 5.5 Adjacent and Other Users

An in-person HAZID Workshop was held with users of properties adjacent to MCT and other stakeholders on October 23, 2025 at the NYCEDC offices at One Liberty Plaza in Manhattan, New York. The list of invited stakeholders is included below, with those in attendance marked with an asterisk (\*):

- Hudson River Park Trust\*
- ConEd (Pier 98)\*
- DSNY (Pier 90)\*
- Miller's Launch
- Coeyman's
- Reicon\*
- Weeks Marine
- Manhattan Community Board 4\*
- Intrepid Museum\*

- New York Cruise Lines\*
- Classic Harbor Line
- MAPONY\*
- Waterfront Alliance
- American Waterways (AWO)
- Manhattan Sailing School
- Manhattan Kayak Co.\*
- Moran Towing Corporation\*
- Hughes Marine
- Village Community Boathouse
- Rocking the Boat
- Atlantic Yachting
- Hudson River Foundation / NYNJ Estuary Program
- Riverkeeper\*
- New York City Soil and Water\*
- Hudson River Park Friends
- Hoboken Cove Community Boathouse
- Ke'Aloha Outrigger
- Manhattan Yacht Club
- Sandy Hook Pilots
- HOPS Education Subcommittee\*
- Hudson River Community Sailing\*
- NYC Water Trail\*
- Manhattan Community Boathouse

As with the other workshops, this meeting included a discussion portion and a HAZID working session. All stakeholders attending provided feedback during the meeting, and two additional stakeholders provided input via email after adjourning.

Recreational boater representatives were cited risks associated with lack of visibility past cruise ships, potential for increased current accelerations or eddies around the extended piers and dolphins, narrowing of the channel for all users, and forcing human-powered

boaters further into the navigable channel. Their biggest concern was generally associated with communicating with other vessels, particularly ferry traffic, to make sure there is safe transit in the area. They noted, however, that communication with cruise ships is generally reliable, and their movements tend to follow predictable patterns, which helps simplify routing for boaters. Environmental groups also were concerned about environmental impact, though that is not within the scope of this study. Other attendees, including agencies and commercial operators, generally did not express major concerns regarding the project, noting other areas of the Hudson that are narrowed that currently don't pose a major issue to vessel traffic. DSNY, ConEd, and the Intrepid Museum, operators of the piers adjacent to MCT, did not anticipate any significant impact or challenges associated with the redevelopment.

Attendees suggested that developing a dialogue with commercial operators, ferry operators, and USCG would assist in reducing risks. They also suggested implementing an escort boat to communicate directly between human powered boaters and other vessel traffic, installing a current meter, and conducting a future hydrodynamic analysis of the extended piers.

The risks and mitigations collected during the workshop are summarized below in Table 5-5.

**Table 5-5: Risk Register from Adjacent and Other Users HAZID Workshop**

Risk ID	Originator	Risk Description	Potential Mitigation Measures
1	NY Outrigger	The potential for extended piers and increased boundary of the USCG security zone will likely cause paddlers to have to stay closer to the center of the channel and away from the more protected waters of shore, which increases the risk of casualties for human powered boaters.	Establishing a human-powered boating corridor that is physically marked by buoys or signage outside of the main navigation channel and outside of the USCG MSZ.
2	NY Outrigger	Fast moving boats who don't communicate adequately via VHF can increase the risk of casualties.	Streamline communication via VHF radio between all vessel operators.
3	HOPS Education Subcommittee	A lack of lighting on the dolphins increases the risks of casualties.	Installation of lighting on dolphins for redeveloped pier structure to ensure that casualties are kept at a minimum.
4	NY Outrigger	The mooring dolphins extending into the faster currents towards the center of the channel have the potential to create a hydrodynamic straining affect that can potentially cause harm to recreational boaters transiting in the area.	It is recommended that a hydrodynamic analysis of the mooring dolphins and pier infrastructure be conducted in the future to understand the effect these structures will have on the water moving past MCT. Future design of these structures should consider the hydrodynamic analysis to ensure that unpredictable currents and straining affects are reduced.

Risk ID	Originator	Risk Description	Potential Mitigation Measures
5	Manhattan Kayak Company	Piers 76 to 99 forms a uniform shoreline that allows cruise ships, tugs, barges, ferries, dinner boats, yachts, speedboats, jet skis, sailboats, and paddlers to travel in roughly parallel paths up and down the river. Smaller, slower traffic—such as paddlers—most often keep outside the main navigation channel, and therefore out of the way of larger boats. Extending some pierheads would break that alignment and force all vessels to shift course around new obstructions, creating choke points, increasing concentration of vessel traffic around the terminal, and increasing collision risk.	Establishing a human-powered boating corridor that is physically marked by buoys or signage outside of the main navigation channel and outside of the USCG MSZ.
6	Manhattan Kayak Company	Longer piers would block sightlines, especially after dark or during sunset glare. Paddlers use white lights, but other vessels may not see them in time. Many vessels are not monitoring VHF, and even when they are, large steel cruise ships can block line-of-sight radio signals between boats on opposite sides. A past ferry/kayak collision off Pier 76 showed how sun glare and missed radio communication can combine to cause serious accidents.	Using a red/green hold up/proceed flag system could be deployed and possibly echoed with a similar flag or light system atop the outermost dolphins.
7	Manhattan Kayak Company	New structures extending far into the river would alter the tidal flow, forcing currents to accelerate around them and creating suction zones. This, combined with turbulent eddies, can capsize, trap, or crush paddlers against structures.	It is suggested that a hydrodynamic analysis of the pier extensions with a cruise ship at berth be conducted in the future.

Risk ID	Originator	Risk Description	Potential Mitigation Measures
8	Manhattan Kayak Company	Cruise-ship support tugs often maneuver without open radio calls, backing and pivoting near the pierheads to dock, undock, and position barges. Extending the piers would leave paddlers less room to stay clear of these operations, forcing them closer to the main navigation channel, where conditions are rougher due to vessel traffic, wakes, and wind.	It is recommended that a hydrodynamic analysis of the mooring dolphins and pier infrastructure be conducted in the future to understand the effect these structures will have on the water moving past MCT. Future design of these structures should consider the hydrodynamic analysis to ensure that unpredictable currents and straining affects are reduced.

## 5.6 NSRA Outcomes Briefing

On December 8, 2025, a hybrid meeting was held with 65 people in attendance both in-person and virtually. All those who were invited to the initial HAZID workshops were reinvited to attend this meeting to discuss the results of the NSRA. In general, attendees were satisfied with the results of the assessment, with a few noting similar concerns as in previous HAZID workshops.

While a risk register was not compiled for this session, stakeholders raised several considerations regarding the terminal redevelopment. The NYC Water Trail Association recommended hydrodynamic modeling to assess potential current variations caused by dolphins at the extended piers. Classic Harbor Lines emphasized the need to understand the configuration of the Maritime Security Zone post-redevelopment. The Manhattan Kayak Company sought clarity on how human-powered and recreational boating activity will be quantified and addressed, particularly given channel constriction. Other members inquired as to the integration of the Blue Highways terminal into the redeveloped layout, but this was outside the scope of this study.

## 5.7 USACE and USCG

An in-person meeting was held with USCG Sector New York personnel on August 27, 2025 at the USCG offices at Fort Wadsworth Staten Island, New York, with additional correspondence with USCG personnel regarding the Maritime Security Zone surrounding MCT.

USCG personnel appeared to be in favor of the Proposed Project. There was no specific feedback regarding potential risks, though they did suggest that the desktop navigation simulation (DNS) scenarios include typical extreme weather conditions experienced on the Hudson River. Typical extreme weather conditions informed by current, wind, and tide data was integrated into the DNS simulations and were vetted by docking pilots working cruise ships in the New York Harbor region.

On September 26, 2025, the consultant team met with USACE virtually to discuss the delineation of the Federally Authorized Channel, with no specific discussion regarding the redevelopment of the terminal.

A virtual meeting was held with the USCG on December 8, 2025 to discuss the results of the NSRA. Overall, participants agreed that the study effectively addressed vessel traffic impacts and associated risks, and they expressed interest in formally reviewing the report and reviewing feedback from the other maritime stakeholders engaged throughout the study. Key discussion points included the need for coordination with the Hudson Cable Project to avoid conflicts with cruise ship schedules, and consideration of future offshore wind activity, as infrastructure expansions at upstate ports may introduce barges with limited maneuverability carrying large turbine components. It was also noted that the Vessel Traffic Service Area of Responsibility (AOR) could extend further up the Hudson River to mitigate these potential impacts.

## 5.8 Practical Mitigation Measures

The Risk Register outlined in Appendix A represents the culmination of the navigational risk assessment undertaken for this study. It consolidates the key risks, potential consequences, and recommended mitigation measures identified through extensive stakeholder coordination. This Risk Register, coupled with the risks quantified through data collection and analysis, SIREN risk modelling outputs, and historical accident reviews, provides insight into the overall risks affecting vessel traffic presently and at the redeveloped terminal.

Insights were gathered from a wide range of stakeholders with local operational knowledge and expertise, such as commercial vessel operators, City Agencies, ferry and passenger vessel operators, and human powered boater groups, among others, whose input was instrumental in contextualizing the potential risks and ensuring the assessment reflects on-the-water realities.

The resulting Risk Register provides a structured summary of the navigational hazards relevant to both existing and future operational scenarios, outlining their likelihood, potential consequences, and practical measures to manage or mitigate these risks moving forward.

During engagement sessions, specific attention was drawn to the presence of human powered boaters in the vicinity of MCT. These small, human-powered craft often operate close to the shoreline but will also transit into areas of commercial vessel movement, particularly during summer months. Their proximity to large vessels and limited maneuverability under strong current or wake conditions pose a mutual safety risk, both to the human powered users and to vessel operators attempting to avoid encounters.

This qualitative risk assessment, informed by stakeholder engagement, offers particularly valuable insights into hazards affecting human-powered boaters—a user group not captured by the SIREN assessment due to the absence of AIS tracking data.

While the risks identified by stakeholders are qualitative in nature and the risk of allisions, collisions, and groundings in the SIREN assessment are quantitative, there are many

overlaps in terms of the potential for these risks to be reduced through the implementation of practical mitigation strategies, such as the following:

- The proposed extended pier length was identified as a risk by stakeholders, including commercial operators and human powered boaters as they will force vessels into the area of the river with a stronger current and potentially increase concentration of vessel traffic in the center channel. This was also identified as a risk through the SIREN assessment, with a small uptick in the likelihood of allisions and collisions as a result of the extended piers. Through stakeholder consultation and assessment of the data, several practical mitigation measures were developed to minimize the impact of this risk, including:
  - ◆ Increasing tug support for barges and other commercial vessels calling at the terminal to aid maneuverability of commercial vessels, barges, and cruise ships.
  - ◆ Future assessment of hydrodynamics around the proposed piers to determine the affect the piers will have on the currents.
  - ◆ Implementation of a safety boat or water traffic controller specifically looking out for the interests of recreational boaters and to assist in case of an emergency involving human powered boaters. In particular, integrating local organizations, such as the Sea Scouts, to provide support.
  - ◆ More stringent enforcement of the MSZ to limit proximity of vessels approaching the pier.
- Currently, there is inadequate communication between human powered boaters and commercial vessel operators. This can lead to potential increase in collisions, as quantified in the SIREN assessment. This risk can potentially be mitigated through initiatives such as the following:
  - ◆ Strengthened public awareness campaigns for the redevelopment of the terminal.
  - ◆ Enhanced signage and lighting at the terminal.
  - ◆ Coordination between local human powered boating organizations and harbor operations subcommittees to improve transit communication.
- A key risk identified by stakeholders was the potential for collision incidents between human powered boaters and ferries due to the increased concentration of ferry transits in the area around MCT coupled with the movement of kayakers, paddle boarders, and others. The SIREN assessment identified that the majority of collision risk in the present condition is also associated with ferries, with a minor increase as a result of the future layout. Several mitigation measures were discussed during stakeholder meetings to mitigate these risks, including:
  - ◆ Sharing route plans of cruise ships, ferries, and human powered boater tours. Currently, ferry operators, commercial operators, and human powered boaters don't

receive arrival or departure schedules of cruise ships and have inadequate communication with each other to plan transits. This will also aid access to emergency responders.

- ◆ Consideration of implementing a human-powered boating corridor that is physically marked by buoys or signage outside of the main navigation channel and outside of the USCG MSZ.

The qualitative aspect of stakeholder consultation together with the quantitative analysis conducted in the SIREN assessment work hand in hand to provide critical insight into development of practical mitigation measures for the future layout of MCT. In particular, it allows for human-powered boaters to be included in the analysis when they otherwise would be excluded.

## 6. Impact of the Proposed Project

### 6.1 Proposed Project Background

The proposed terminal would include the demolition of all three existing piers, Piers 88, 90, and 92, and the reconstruction of a new North Pier and South Pier in the approximate locations of the existing Piers 88 and 92. The new North and South Piers will extend approximately 198 meters (650 feet) farther into the Hudson River beyond the current Federally Authorized Channel limit than the existing terminal. Of this extension, approximately 93 meters (305 feet) would be pier extension and approximately 105 meters (345 feet) would be associated with mooring dolphins. Part of the reason that the piers extend further into the Hudson is because terminal services—such as security screening, baggage handling, customs, and ground transportation—have been consolidated into a new upland facility, necessitating the piers' outward expansion.

To guide the design of the facility layout, a design vessel was chosen to illustrate the typical cruise ship that is expected to call at MCT in the future. In the current cruise ship market, the largest vessels in the cruise ship fleet call at ports in Florida and the US South. The next-largest of the cruise ships, typically in the size range of a Breakaway Plus Class ship, currently call at MCT. Based on market projections and the current cruise ship orderbook, the Icon Class vessel was used for the project impact analysis and desktop navigation simulations to represent this second tier of vessel size, as it is the vessel class sailing today which most closely aligns with the vessels expected to call at the redeveloped MCT.

The layout was also planned so that there would be sufficient space for cruise ships maneuvering into MCT with tug assists, for bunkering and support vessels to moor alongside, and for emergency response vessels to respond when necessary.

The proposed pier layout was planned for three total berths able to accommodate two Icon Class sized cruise ships in the center berths and one Breakaway Plus sized vessel on the southern side of the southern pier.

Cruise ships calling at MCT have a harbor pilot, typically Sandy Hook Pilots, providing guidance through New York Harbor, and will often have a docking pilot onboard with assist tugs to provide berthing assistance to the ship's captain. At MCT, docking pilotage is typically provided by Metro Pilots and tugs provided by Moran.

## 6.2 Existing Vessel Traffic

### 6.2.1 Introduction of AIS Data and Data Sources

AIS data provides the record of vessel activity within the study area and serves as the foundation for characterizing existing navigation patterns around MCT. AIS data includes time-stamped information transmitted automatically by transponders aboard vessels, containing position (latitude, longitude), speed over ground, course over ground, vessel identity (MMSI, IMO number, name), type, and dimensions – including length, width, and draft, and navigational status. This dataset enables detailed reconstruction of vessel movements, including the identification of primary transit corridors, maneuvering areas, and operational hotspots within and around the project footprint.

For this assessment, AIS data was obtained from the US Marine Cadastre database, jointly maintained by NOAA and the Bureau of Ocean Energy Management (BOEM). Marine Cadastre provides a nationally consistent, quality-controlled archive of terrestrially sourced AIS records for US coastal and inland waters.

Data from the 2023 and 2024 calendar years were extracted to ensure adequate temporal coverage and to account for recent trends, as well as potential annual variability in vessel activity. Each AIS message contains a unique vessel identifier (MMSI), positional information, vessel type, dimensions, speed, and course, allowing for differentiation of vessel classes and analysis of route characteristics.

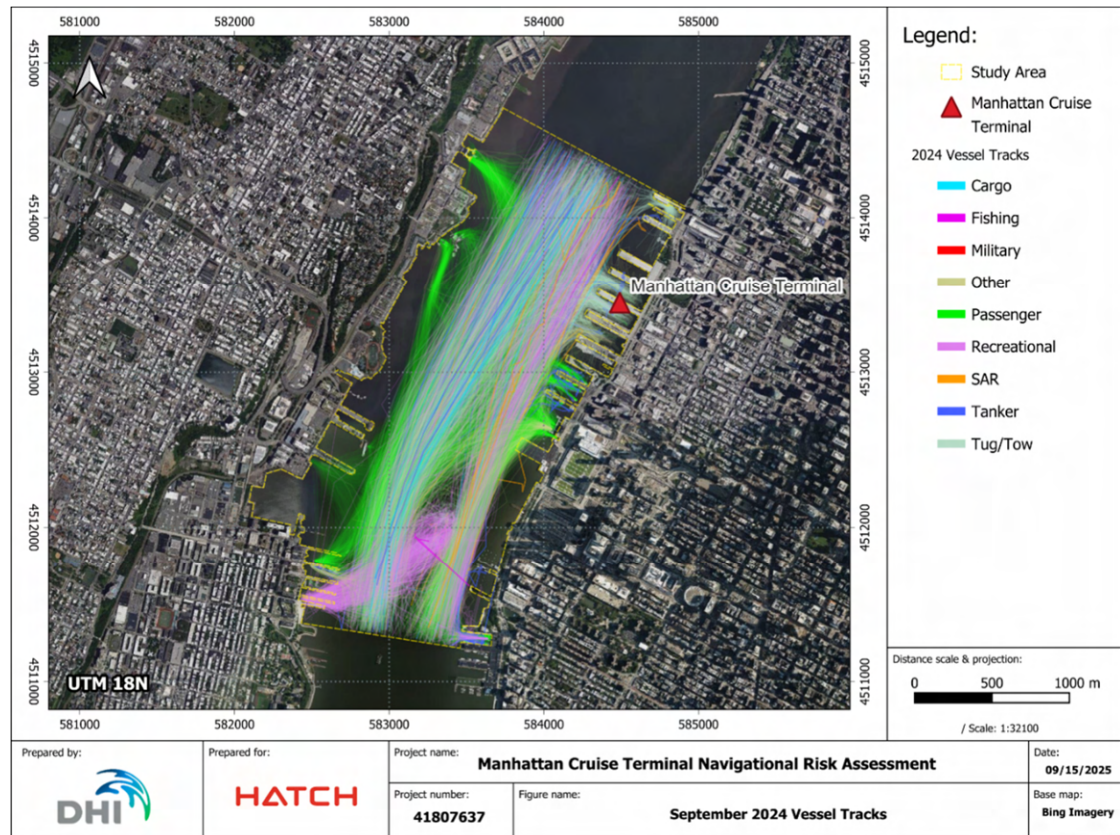
### 6.2.2 Overview of Existing Vessel Traffic Patterns in Study Area

A representative visualization of vessel track lines from September 2024 is shown in Figure 6-1, illustrating typical traffic patterns within the Study Area. The area is generally characterized by high-frequency ferry operations transiting between multiple piers along both the New Jersey and New York shorelines. The dominant traffic patterns consist of short, repetitive ferry crossings between Midtown Manhattan and the New Jersey waterfront (including Weehawken, Hoboken, and Jersey City). These routes form a dense network of overlapping paths concentrated generally south of the Proposed Project, reflecting the operational focus of ferry services in this portion of the Hudson River corridor.

In addition to ferry traffic, moderate levels of cruise, tug, and other vessel traffic (e.g. pilot vessels, harbor service craft), are present in the system, with the remaining vessel types (cargo, tanker, recreational, search-and-rescue (SAR), military, and fishing) making up a relatively small proportion of overall traffic.

In the Project Impact Analysis, passenger vessels refer to ferries, tour boats, and smaller passenger transportation vessels, with cruise ships analyzed separately.

In this section of the report, passenger vessels refer to cruise ships as well as ferries, dinner cruise boats, and other commercial vessels used to transport people. Additionally, recreational boaters refer to smaller motorized vessels that transmit AIS data and can thus be tracked and quantified, as opposed to human-powered boaters who operate recreationally on the Hudson but cannot be tracked.



**Figure 6-1: September 2024 Vessel Tracks by Type Inside the Study Area**

To quantify spatial traffic intensity, AIS-derived vessel track lines were processed to compute track line density maps at a 10 meter by 10 meter (approximately 33 foot by 33 foot) spatial resolution across the Study Area. These maps depict the relative frequency of vessel transits through each grid cell, providing a high-resolution visualization of the most heavily utilized navigation corridors. The values depicted in these density maps represent the number of times a vessel crossed each pixel in the map.

The results are presented in Figure 6-2 and Figure 6-3 for 2023 and 2024, respectively, which highlight concentrated passenger vessel (non cruise) corridors generally south (and, to a lesser extent, the northwest) of the terminal, distinct crossing paths between New Jersey and Manhattan, and relatively lower overall activity levels near the immediate vicinity around the extent of the existing MCT footprint.

The detailed outputs and maps for each identified vessel type are presented in Appendix F. Appendix E and Appendix F contain both the full vessel track line plots and corresponding traffic density maps for that specific class of vessel, enabling a granular understanding of navigation behavior and spatial utilization across vessel categories.

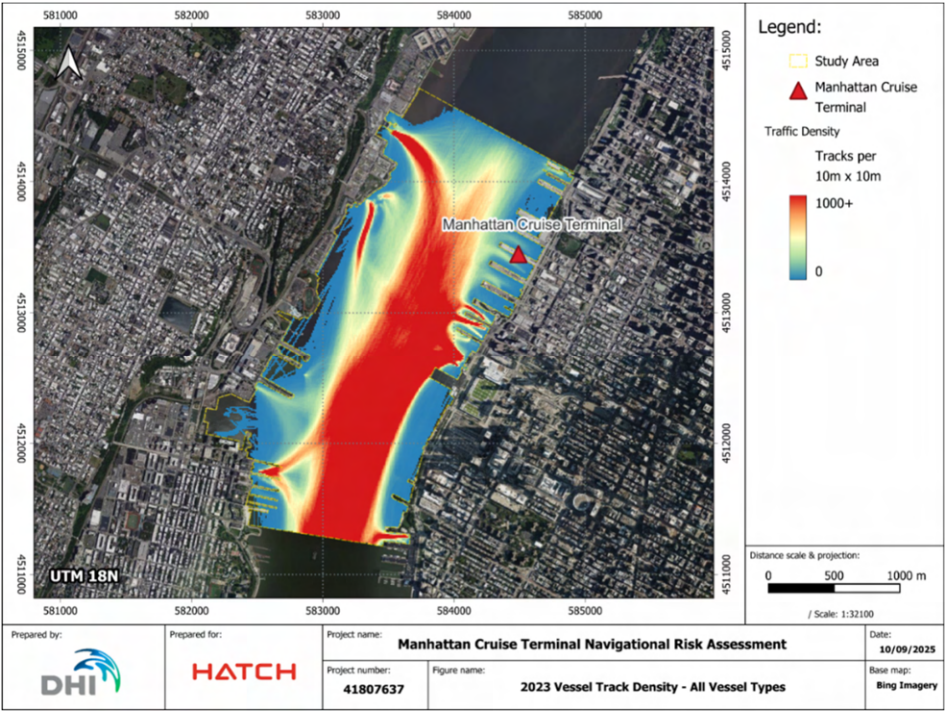
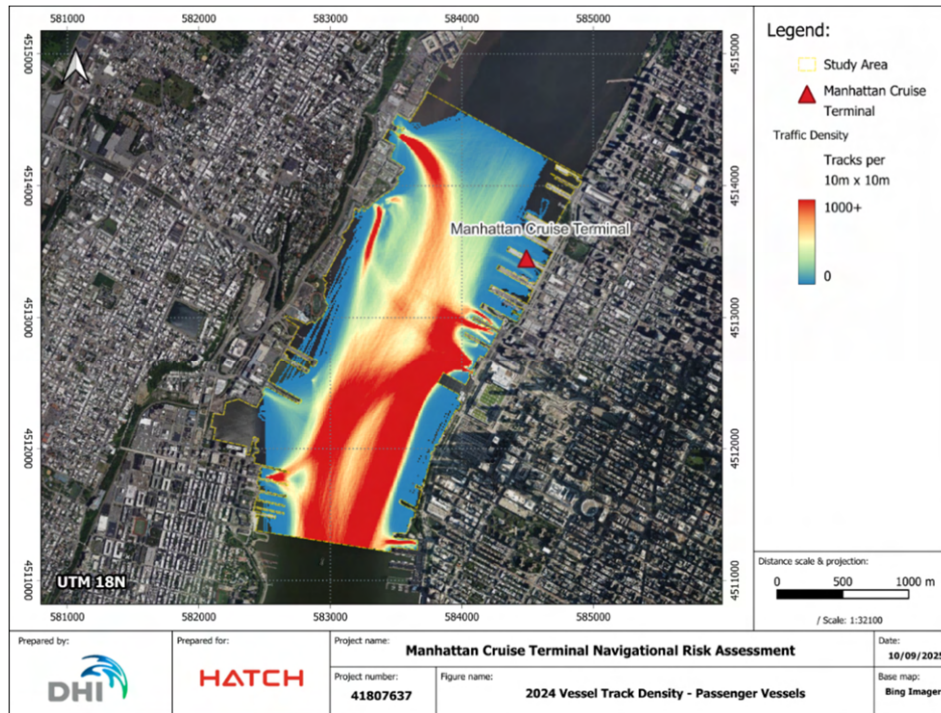


Figure 6-2: 2023 Vessel Track Density for All Vessel Types in the Study Area

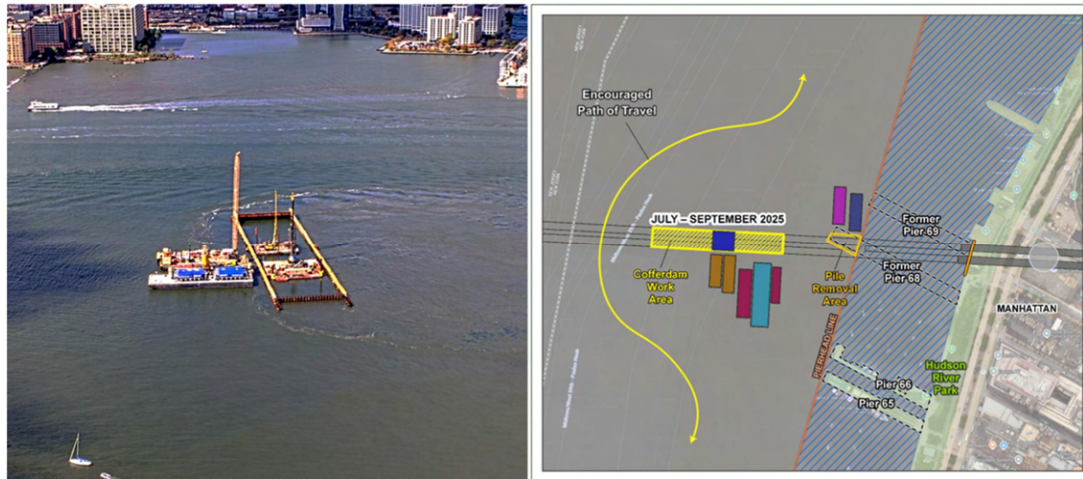


**Figure 6-3: 2024 Passenger Vessel (non cruise) Track Density in Study Area**

### 6.2.3 Existing Temporary Impacts to Navigation

A localized diversion of vessel density is evident in the southern portion of the Study Area, corresponding to the Gateway Development Commission’s Hudson River Grounds Stabilization (HRGS) Project, as discussed in Section 4.3. In 2024, construction activities associated with this project included the installation of a Temporary Containment System (cofferdam) to facilitate deep soil mixing operations from inside, all within the middle of the Hudson River near Pier 68. This resulted in a temporary exclusion zone that has altered localized navigation patterns. The AIS-derived density maps show a clear bifurcation and curvature of vessel routes around this restricted area, confirming behavioral adaptation to the temporary obstruction.

These HRGS activities are anticipated to continue through approximately 2027, after which the cofferdam will be removed. Through conversations with the chief engineer of the HRGS project, it was reported that the 2024 river mudline will be maintained and materials will not be allowed to intrude into (above) the 13.7-meter-deep (45-foot) Federally Authorized Channel prism. As such, bathymetric and navigational conditions are expected to return to a state similar to current baseline conditions. Consequently, while the 2024 AIS data reflect a temporary redistribution of vessel density in this sector, these effects are not expected to represent long-term navigation patterns within the study area. The presence of these operations and the recommended traffic diversion scheme are depicted in Figure 6-4.



**Figure 6-4: Gateway Development Commission Hudson Tunnel Project Cofferdam and Recommended Traffic Diversion Scheme (adapted from GDC (2025))**

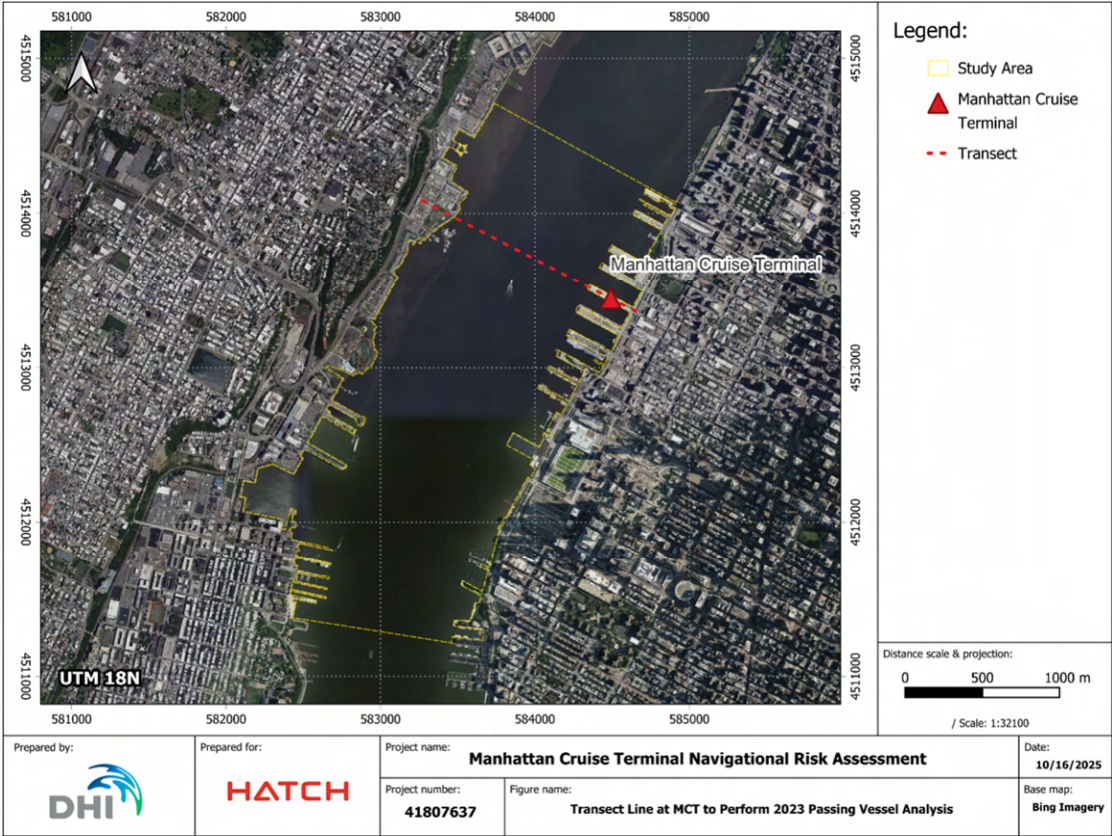
#### 6.2.4 ***Existing Traffic Characterization around the Manhattan Cruise Terminal***

To complement the broader Study Area analysis, a localized assessment of vessel traffic was conducted in the immediate vicinity of MCT. This analysis focused on quantifying the number and characteristics of vessel passages directly adjacent to the terminal, providing a refined understanding of traffic patterns at this key location.

To conduct this analysis, a cross-sectional analysis was developed by intersecting all AIS track lines with a transect line drawn perpendicular to the shoreline at the MCT piers. This approach provides a direct count of vessel crossings through the immediate MCT vicinity.

This methodology was selected because many vessels operating in the Hudson River maintain continuous AIS transmissions for long durations, often without clear gaps between individual trips. As a result, simple trajectory segmentation can distort prolonged vessel presence or fail to distinguish discrete movements. By quantifying crossing counts, the analysis captures the true frequency of vessel movements past the terminal, yielding a robust measure of localized traffic patterns. This transect line is depicted in Figure 6-5.

Table 6-1 shows the total number of vessel crossings by vessel type during 2023 summarizing the same data numerically. The results demonstrate that vessel traffic in the immediate vicinity of MCT is dominated by passenger (ferry and cruise) vessels with towing vessels forming the next most frequent category. Together, in 2023, these two categories of vessels make up approximately 92% of all movements by MCT. In total, approximately 71,000 individual vessel crossings were recorded at the MCT transect during 2023.



**Figure 6-5: Transect Line at MCT to Perform Passing Vessel Analysis**

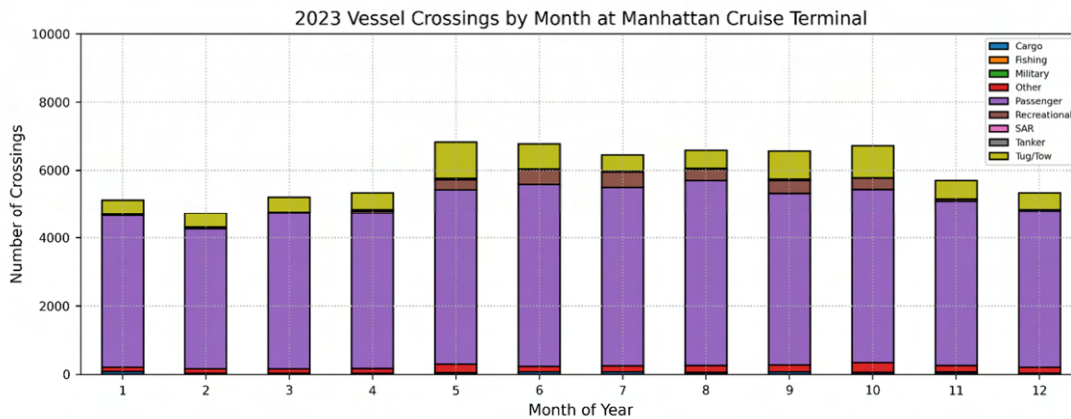
**Table 6-1: 2023 Breakdown of Vessel Crossings by Type at MCT**

Vessel Type	Number of Crossings	Percentage of Total Crossings
Cargo	704	0.99%
Fishing	15	0.02%
Military	2	0.00%
Other	2,144	3.00%
Passenger	58,385	81.81%
Recreational	2,425	3.40%
Search-and-Rescue (SAR)	153	0.21%
Tanker	154	0.22%
Tug/Tow	7,388	10.35%
<b>Total</b>	<b>71,370</b>	<b>100.00%</b>

This same detailed breakdown of movements for the period of 2024 is also available in Appendix E, showing a similar trend.

A month-by-month breakdown of vessel crossings (Figure 6-6) indicates that overall traffic levels remain relatively consistent throughout the year. This reflects the steady operation of commuter ferry services, which constitute the majority of movements in the area.

A modest seasonal increase in both passenger vessel and recreational vessel crossings is observed during the late spring, summer, and early fall months (May through October), consistent with higher levels of leisure boating activity during favorable weather conditions.

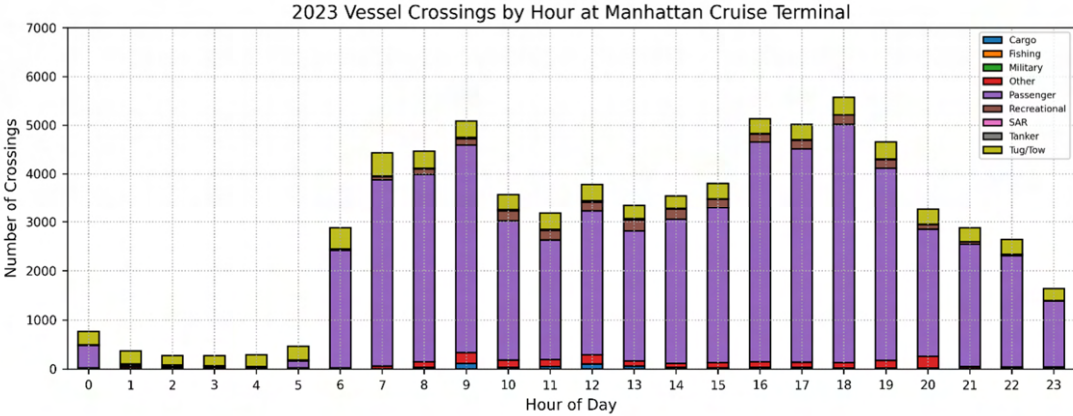


**Figure 6-6: 2023 Monthly Breakdown of Vessel Crossings by Type at MCT**

The distribution of vessel transits by hour of day (Figure 6-7) highlights a clear daily pattern. Traffic levels begin to rise sharply in the early morning hours (around 5am to 6am), corresponding to the onset of morning ferry operations. Activity decreases during the late morning and early afternoon, but remains sustained throughout daylight hours, with a pronounced peak in the late afternoon and early evening again corresponding to increased ferry traffic. The high traffic periods in the morning and late afternoon also correspond to typical times when cruise ships are berthing and unberthing at MCT.

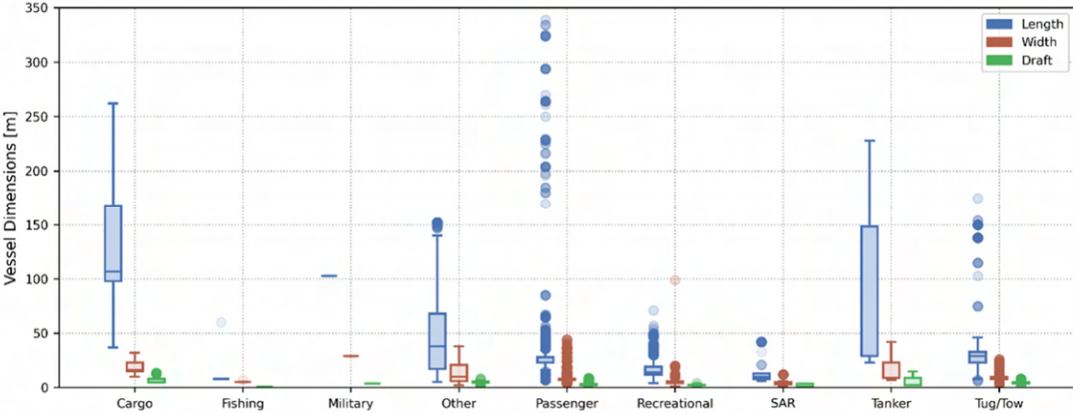
Following this peak, traffic levels decrease markedly overnight, with minimal vessel crossings occurring between midnight and sunrise, reflecting reduced ferry operations and limited commercial movements during nighttime hours. This daily rhythm underscores the strong influence of passenger ferry operations on localized vessel dynamics near MCT.

Approximately 75% of all movements by MCT in 2023 occurred during the hours of 6am through 6pm.



**Figure 6-7: 2023 Hourly Breakdown of Vessel Crossings by Type at MCT**

To further characterize localized vessel traffic at MCT, vessel dimensions were analyzed for all crossings in 2023, considering length overall, beam (width), and draft. These metrics provide insight into the operational envelope and footprint of associated vessel traffic. The analysis is presented both visually, using a boxplot (Figure 6-8), and numerically in Table 6-2.



**Figure 6-8: 2023 Distribution of Vessel Dimensions at MCT for Length, Width, Draft (as reported in AIS)**

A boxplot summarizes the distribution of a dataset and highlights central tendency, variability, and potential outliers. The key elements include:

- Median (central line within the box): The value separating the upper and lower 50% of the data.
- Interquartile range (IQR; the box extents): The range between the 25th percentile (Q1) and the 75th percentile (Q3), representing the middle 50% of observations.
- Whiskers: Lines extending from the box to the smallest and largest values within 1.5 × IQR from the quartiles, showing the typical range of data.

- Outliers (points beyond the whiskers): Individual data points that are unusually large or small relative to the main distribution.

This visualization enables identification of typical vessel dimensions, as well as extreme cases that may impose additional navigational considerations.

The boxplot and table illustrate several key trends:

- Passenger vessels: A high concentration of smaller ferry vessels is evident, with median lengths and beams reflecting routine ferry transit operations. Extreme large values in this category represent large cruise ships, which exceed the typical ferry dimensions and define the upper bounds of the envelope.
- Cargo and tanker vessels: These categories make up some of the largest vessels transiting near MCT, although they constitute a relatively small portion of total traffic.
- Towing vessels: This category includes tugs assisting cruise ships during maneuvering at MCT, as well as tugs with barges in tow transiting past the terminal or calling at the terminal for bunkering services. The size of the tugs alone is relatively small in all dimensions, but their overall size can increase significantly when connected to a barge.
- Other vessels<sup>18</sup>: This category includes many types of vessels, but for the area around MCT are generally associated with diving or dredge support vessels and law enforcement vessels. These vessels are typically small in all dimensions and account for a small percentage of all crossings near the terminal.
- Recreational, SAR, and Fishing vessels: These categories are predominantly relatively small and consist of a limited population of crossings, making statistical characterization challenging. The spread of dimensions in these categories is narrow and extreme values are few, corresponding to isolated outlier vessels.

Overall, the analysis confirms that while the majority of traffic near MCT consists of relatively small vessels (primarily ferries and to a lesser extent tugs) the presence of occasional large cruise ships, cargo, and tanker vessels defines the upper bounds of navigational and maneuvering requirements. These observations are critical for informing risk assessment, terminal design considerations, and simulation scenarios in subsequent tasks.

This same breakdown of information for 2024 vessel traffic is shown in Appendix F.

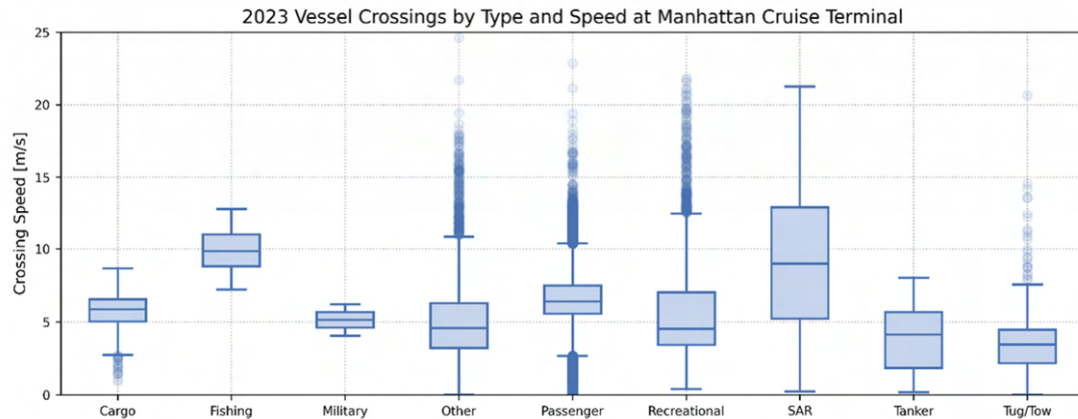
---

<sup>18</sup> **Marine Cadastre Project.** *AIS Vessel Type and Group Codes Used by the U.S. Coast Guard, NOAA, and BOEM.* May 23, 2018.

**Table 6-2: 2023 Breakdown of Vessel Dimensions Transiting Near MCT Based on Length, Width, Draft (as reported in AIS)**

<b>Dimension/Type</b>	<b>Cargo</b>	<b>Fishing</b>	<b>Military</b>	<b>Other</b>	<b>Passenger</b>	<b>Recreational</b>	<b>SAR</b>	<b>Tanker</b>	<b>Tug/Tow</b>
Mean Length (m)	119.7	11.5	103.0	49.5	27.8	17.0	15.2	85.6	30.0
Std. Dev. Length (m)	50.8	13.0	0.0	41.9	11.4	8.2	11.5	66.1	14.8
Min. Length (m)	37.0	8.0	103.0	5.0	7.0	4.0	6.0	23.0	6.0
Max. Length (m)	262.0	60.0	103.0	152.0	339.0	71.0	42.0	228.0	175.0
Mean Width (m)	18.9	5.1	29.0	12.2	7.5	5.1	5.1	16.1	9.2
Std. Dev. Width (m)	7.0	0.5	0.0	7.9	1.5	3.5	2.9	8.8	2.6
Min. Width (m)	10.0	5.0	29.0	2.0	4.0	1.0	1.0	7.0	3.0
Max. Width (m)	32.0	7.0	29.0	37.9	44.0	99.0	12.0	42.0	26.0
Mean Draft (m)	6.5	0.5	3.5	4.6	3.1	2.3	2.0	5.1	4.4
Std. Dev. Draft (m)	2.6	0.0	0.0	1.4	2.0	0.5	1.3	3.5	1.1
Min. Draft (m)	4.8	0.5	3.5	0.5	1.2	0.7	1.0	2.0	1.3
Max. Draft (m)	13.9	0.5	3.5	8.3	8.6	4.0	3.7	14.8	7.9

A detailed assessment of vessel speeds was conducted for all crossings at MCT during 2023. The analysis is again visualized using a boxplot.



**Figure 6-9: 2023 Distribution of Vessel Speeds Passing MCT**

The analysis indicates that the majority of vessel traffic passes MCT at speeds of approximately 5 to 10 m/s (approximately 10 to 20 knots), and in many cases slower. This range corresponds to normal cruising speeds for the predominant vessel types in the study area.

- **Passenger vessels:** While most ferries operate within the 5 to 10 m/s range, the slowest observed speeds reflect approach and departure maneuvers at the terminal. Cruise ships, in particular, slow significantly when berthing or departing, producing very low-speed observations captured in the AIS data.
- **Tugs:** Slow speeds are common for these vessel types as they perform assist maneuvers for cruise ships or transit with barges in tow.
- **Other vessels:** Slow speeds are common for these vessels as dredge and dive support vessels typically idle near MCT. However, as this category incorporates a large swath of vessel types, there are instances of vessel crossings in the area that are greater than the average.
- **Cargo and tanker vessels:** These vessels typically maintain speeds centered around the 5 m/s (approximately 10 knots) range while transiting past the terminal.

This information regarding vessel passing speeds formed the basis of model inputs for the vessel wake impact assessment (detailed in Section 6.4).

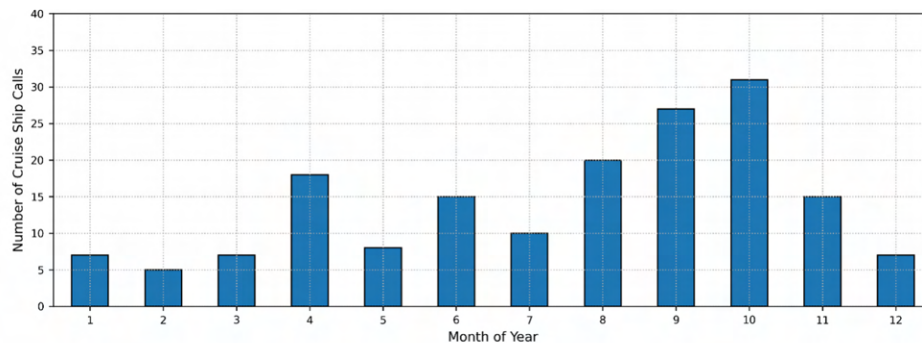
This same breakdown of information for 2024 vessel traffic is shown in Appendix G.

## 6.2.5 Cruise Ship Activity at MCT

To better understand the cruise ship activity at MCT, a detailed assessment of cruise ship calls was conducted using a combination of port call records from Ports America, which operates MCT under a lease agreement with NYCEDC, and AIS data for the 2023 and 2024 calendar years.

In 2023, a total of 176 cruise ship calls were verified between the datasets at MCT, while 2024 saw slightly fewer calls at 166. It should be noted that Ports America port call logs were only available for seven months in 2023 (January, February, March, April, May, June, and December), omitting some of the busiest periods for cruise activity at the terminal; for these months the quantification relied solely on AIS data records.

A histogram of monthly cruise ship calls in 2023 (Figure 6-10) illustrates the temporal distribution of terminal activity. These data indicate a pronounced uptick in the fall months, particularly September and October, which aligns with the seasonal cruise ship schedule. Secondary peaks are observed in April, August, and November, reflecting transitional periods in the cruise calendar. The histogram highlights the seasonality of cruise operations and underscores the importance of considering temporal clustering in navigational risk assessments and terminal operations planning.

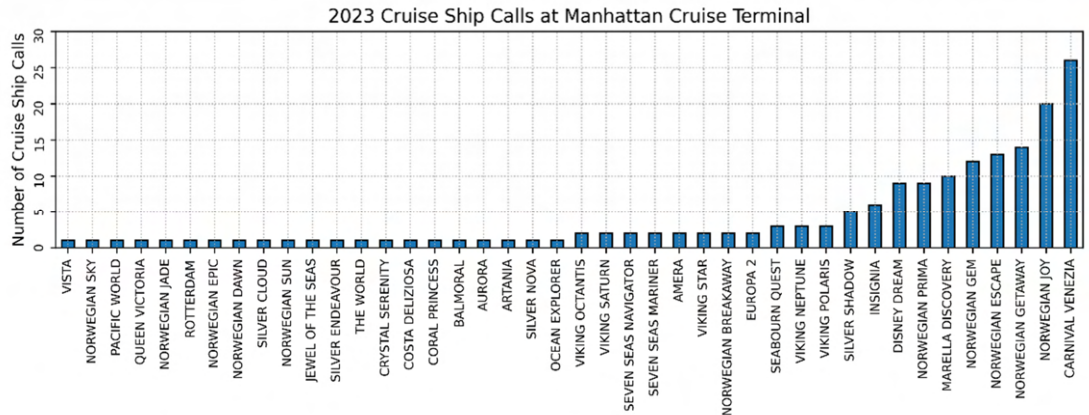


**Figure 6-10: 2023 Cruise Ship Calls at MCT Broken Down by Month**

Further analysis of individual vessel call frequency at MCT provides insight into the operations of recurring cruise ships. A histogram of cruise ship calls by individual vessels (Figure 6-11) reveals that the top six most frequently visiting vessels in 2023 account for more than 50% of all calls at the terminal. These include the following cruise ships:

- Costa Venezia
- Norwegian Joy
- Norwegian Getaway
- Norwegian Escape
- Norwegian Gem
- Marella Discovery

These vessels represent the core fleet driving MCT operations and are critical to understanding recurring navigational patterns, berth scheduling, and risk exposure. Remaining vessels call less frequently, often appearing only sporadically, and contribute to the overall diversity of traffic but less so to regular congestion or operational predictability.



**Figure 6-11: 2023 Cruise Ship Calls at MCT Broken Down by Individual Vessels**

An analysis of cruise ship operations at MCT in 2023 reveals a clear distribution of vessel calls across available berths. Approximately 66% of cruise ships berthed at Pier 88 North, representing the primary operational berth for the majority of scheduled arrivals and departures. Pier 90 North accommodated roughly 25% of cruise ship calls, and the remaining approximately 9% of calls occurred at Pier 88 South, reflecting limited utilization of the southern berth, typically reserved for smaller vessels or occasional operational contingencies when others were not available. In 2024, a similar pattern was revealed, showing allocations of approximately 68%, 20% and 12% of cruise ship calls going to berths at Pier 88 North, Pier 90 North, and Pier 88 South, respectively.

To evaluate the role of tug support in cruise ship operations at MCT, tug assist data from Moran Towing was intersected with AIS vessel tracks and call records provided by Ports America. This combined dataset allowed for a detailed assessment of tug utilization for both arrival and departure maneuvers. This provides valuable insight for not only the baseline of safe navigation into and out of the terminal, but also for the increased associated footprint of the “convoy” of vessels presenting navigational constrictions during these maneuvers.

A pie chart illustrating tug usage during 2023 cruise ship arrivals at MCT (Figure 6-12) indicates a nearly even split between vessels requiring tug support and those operating independently:

- No tug assist: approximately 43% of arrivals
- 1 tug assist: approximately 47% of arrivals
- 2 tugs assist: approximately 9% of arrivals

This distribution highlights that nearly half of all cruise ship arrivals rely on a single tug to facilitate safe maneuvering within the terminal vicinity, while a small proportion require two tugs. This would typically be for the largest vessels or under constrained environmental conditions, but also includes factors such as cruise line standard operating procedures, which may necessitate the use of tugs regardless of environmental conditions.

Tug usage for departures shows a markedly different pattern (also shown in Figure 6-12). In 2023, the majority of vessels departed without tug assistance:

- No tug assist: approximately 88% of departures
- 1 tug assist: approximately 12% of departures
- 2 tugs assist: less than 1% of departures

This trend reflects operational practices at MCT, where vessels mainly rely on tug support (if used) during berthing operations to ensure precise positioning at the terminal. Departures generally consist of vessels maneuvering independently.

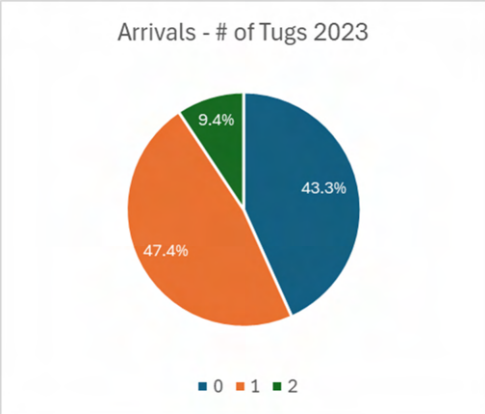


Figure 6-12: 2023 Cruise Ship Tug Assists at MCT by Arrival (Source: Moran Towing)

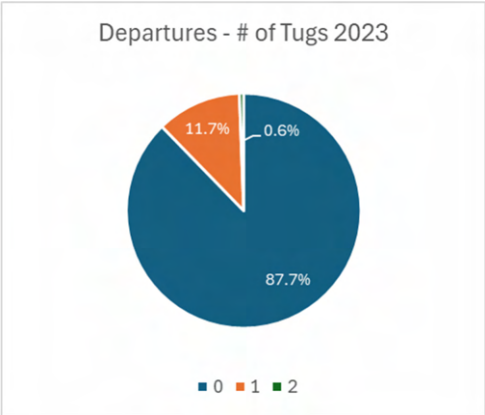
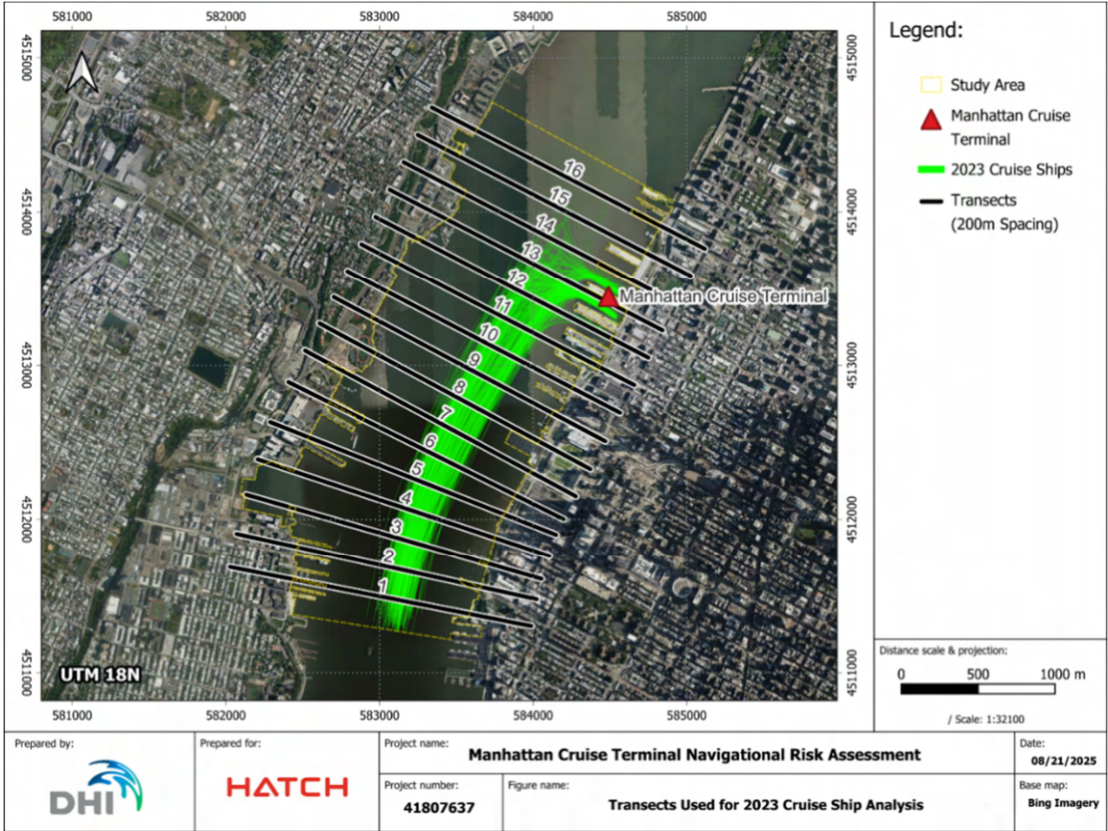


Figure 6-13: 2023 Cruise Ship Tug Assists at MCT by Departure (Source: Moran Towing)

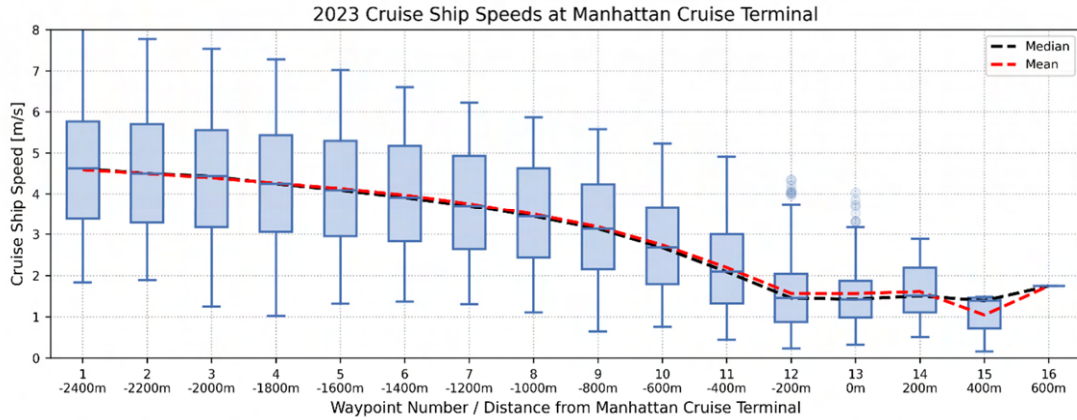
To assess cruise ship operational behavior approaching and departing MCT, AIS track lines coming from cruise ships were intersected with a series of regularly spaced transects positioned 198 meters (approximately 650 feet) apart along the centerline of the Hudson River. This approach allows for detailed evaluation of vessel speeds along their transit route and within the terminal vicinity.

Figure 6-14 depicts the spatial distribution of cruise ship movements and the positions of the transects used in the analysis. The map provides a visual overview of cruise ship routes, highlighting the primary navigation corridors and locations where speed measurements were captured. This spatial context is critical for interpreting speed variations in relation to river geometry, traffic density, and terminal approach patterns.



**Figure 6-14: 2023 Cruise Ship Call Tracks to and from MCT and Transects used for Speed Profile Analysis**

The corresponding speed profile (Figure 6-15) summarizes vessel speeds at each transect, using boxplots to represent the distribution, along with median and mean speeds for each location along the route.



**Figure 6-15: 2023 Cruise Ship Speed Profiles to and from MCT**

Cruise ships maintain a near-constant cruising speed of approximately 5 m/s (10 knots) towards the southern extent of the Study Area, reflecting normal transit operations along the Hudson River up to this location.

As vessels approach the MCT berths, speeds gradually decrease, with maneuvering speeds typically reaching 1.5 m/s (3 knots) or less. This deceleration corresponds to precise berthing and docking operations, where slow, controlled movements are essential for safe alignment with terminal infrastructure.

These observations demonstrate the transition from cruising to terminal maneuvering, providing important input for navigational risk assessments. The consistent cruising speeds establish baseline conditions for transit interactions with other traffic, while the low approach speeds near MCT highlight areas of concentrated and extended periods of increased maneuvering risk (where their footprint is largest), particularly when combined with background traffic in the terminal vicinity. These insights will inform subsequent risk modelling (detailed in Section 7), ensuring accurate representation of vessel behavior under different operational conditions.

This same breakdown of information for 2024 cruise ship traffic is shown in Appendix H.

### 6.3 Evaluation of the Proposed Project Footprint

#### 6.3.1 Impacts to Passing Vessel Proximity at MCT

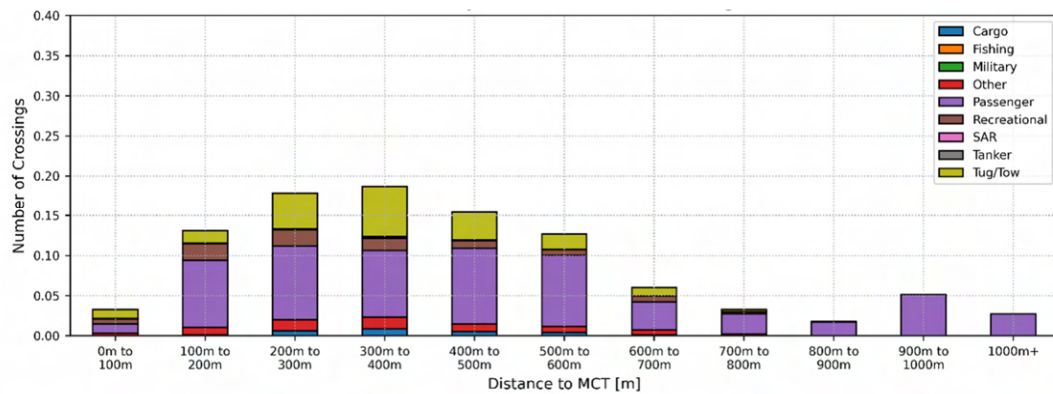
The purpose of this section is to evaluate the potential impacts of the proposed MCT expansion on vessel maneuvering space, turning circles, and approach/departure angles for both the terminal and adjacent berths. This analysis provides a high-level assessment of how the extension of the terminal footprint into the Hudson River may influence traffic patterns, vessel interactions, and navigational risk.

The methodology focuses on spatial analysis of vessel passing distances relative to the existing terminal. Historical AIS tracks were used to determine the distance distribution of vessel passages from the terminal edge and the proportion of traffic that currently transits

within specific distance intervals. This data was subsequently used to assess the Proposed Project’s encroachment into existing traffic corridors, which would require vessels to shift outward to maintain similar passing proximities. The resulting changes in vessel density across the navigable channel were quantified.

Figure 6-16 presents a histogram of vessel passages binned by distance from the edge of the existing terminal. The distribution closely resembles a skew-Gaussian (normal) distribution, with the majority of traffic concentrated around the 300–400 meter (984-1,312 foot) distance interval. This indicates that most vessels, regardless of type, transit at a distance from the terminal that is outside the extent of the proposed expansion and reflects established navigation patterns along the Hudson River near MCT.

The figure presents only passing vessels and excludes cruise ships calling at MCT.

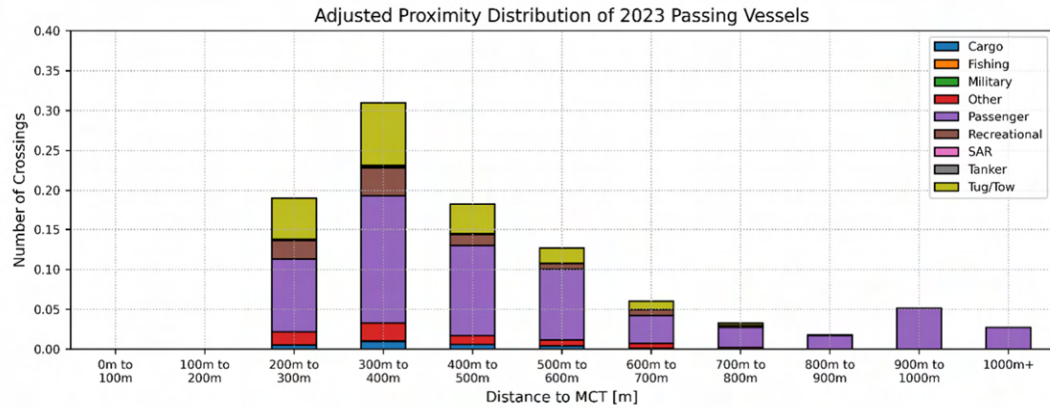


**Figure 6-16: 2023 Existing Passing Vessel Distance Distribution to MCT**

Overall, the Proposed Project will extend approximately 209 meters (686 feet) beyond the current terminal footprint into the Hudson River. Of this total extension, the outermost 198 meters (650 feet) will encroach into the Federally Authorized Channel. Vessels whose existing transit paths would now overlap with the new terminal boundary will need to shift further outward to maintain the same safe passing proximity.

Using this assumption, Figure 6-17 presents a histogram showing an assumed adjusted distribution of vessel passages, accounting for the required outward shift. The chart highlights how the extension redistributes traffic across the Hudson River, altering local density patterns and requiring navigational consideration. The figure presents only passing vessels, and excludes cruise ships calling at MCT.

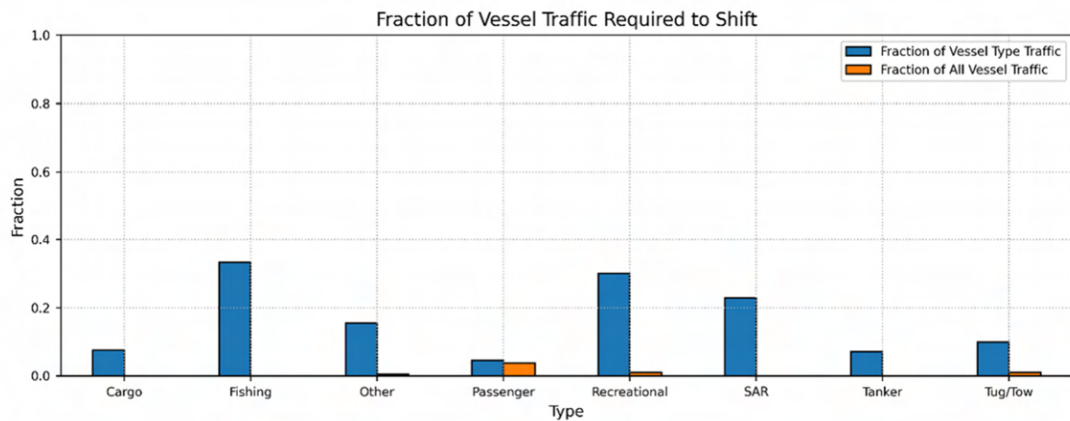
Given that the proposed terminal expansion extends approximately 209 meters (686 feet) further into the Hudson than the current footprint, vessels transiting beyond this limit would not necessarily have to change their operations. As outlined in the figure below, the change in vessel distribution occurs only up to the 400- to 500-meter (1,312- to 1,640-foot) distance interval. Beyond this, it is expected that vessels could continue their current behavior and still maintain safe passing distances.



**Figure 6-17: 2023 Proposed Future Passing Vessel Distance Distribution to MCT**

To better understand operational implications, Figure 6-18 summarizes the percentage of vessels by type that would need to shift their routes outward due to the Proposed Project. The figure presents two perspectives:

- Percentage of traffic per vessel type affected, showing each vessel category relative to its own total movements passing by MCT.
- Percentage of traffic per vessel type relative to all traffic passing by MCT, providing context for the overall impact on Hudson River traffic.



**Figure 6-18: 2023 Existing Passing Vessels At MCT Affected by Proposed Footprint**

This same information is tabulated in Table 6-3.

This analysis reveals that the most impacted vessel types consist of passenger, tug, and recreational vessels, albeit a very small proportion. When compared to overall movements passing by MCT (excluding cruise ships), approximately 6% of all movements would need to shift their routes to accommodate the Proposed Project.

**Table 6-3: 2023 Existing Passing Vessels at MCT Affected by Proposed Project**

Vessel Type	Percentage of Vessel Type Traffic	Percentage of All Vessel Traffic
Cargo	7.53%	0.07%
Fishing	33.33%	0.01%
Other	15.43%	0.46%
Passenger	4.56%	3.73%
Recreational	30.14%	1.02%
SAR	22.88%	0.05%
Tanker	7.14%	0.02%
Tug/Tow	9.94%	1.03%
All	-	6.39%

This same breakdown of information for 2024 vessel traffic is shown in Appendix I.

### 6.3.2 ***Impacts to Vessel Turning Circles and Maneuvering at MCT***

To evaluate the impact of the Proposed Project on vessel maneuvering and turning circles, the arrival and departure tracks of cruise ships were analyzed to isolate the portions of their movements corresponding to active terminal maneuvers. This subset of AIS data represents the segments where vessels are turning into or out of the terminal, and therefore the areas where shifts in position would be required to maintain safe proximity to terminal structures under the proposed extension.

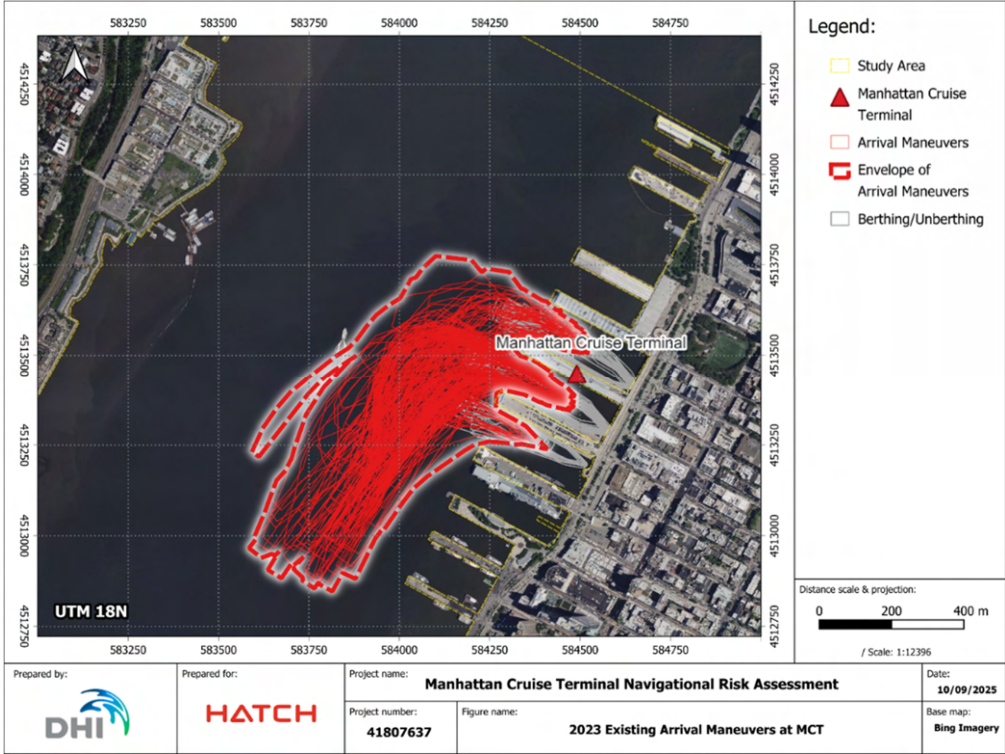
Two sets of maps were developed to visualize current operational patterns:

- Arrival Maneuvers: A map showing individual swept paths of all cruise ship arrivals, overlaid with a combined footprint representing the aggregated area utilized during arrival maneuvers for 2023 is depicted in Figure 6-19.
- Departure Maneuvers: A similar map depicting individual and combined departure envelopes for 2023 is depicted in Figure 6-20.

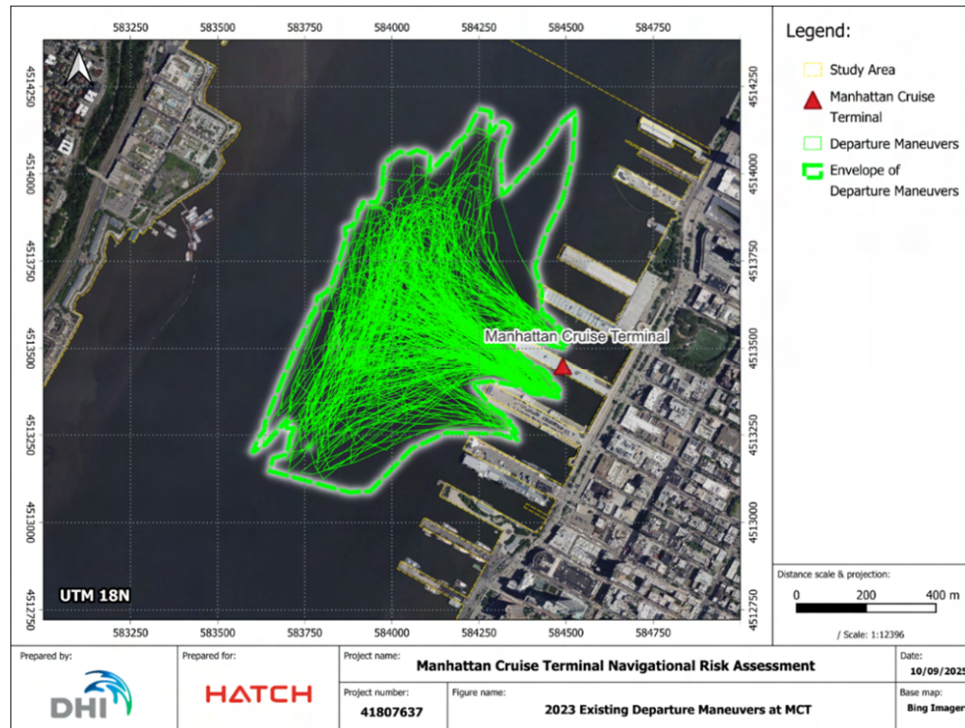
These maps illustrate the spatial footprint of cruise ship maneuvers, highlighting areas of navigational constriction and the portions of the Hudson that are effectively blocked during these movements.

The analysis of existing arrival and departure maneuvering envelopes shows that cruise ships at MCT currently occupy a substantial portion of the Hudson River, effectively restricting navigable space for other vessels along approximately half the width of the river. During departures, the swept paths extend slightly further toward the New Jersey side, reflecting the turning arcs required for vessels to safely align with their transit corridor as they exit the terminal. This lateral shift during departure emphasizes the dynamic nature of vessel maneuvering and the spatial implications for concurrent traffic in the Hudson.

The envelopes also highlight the close proximity of maneuvers to the ends of the piers, which is necessary for vessels to berth effectively. Cruise ships must approach the piers with precise alignment to maintain safe clearance from adjacent vessels and terminal structures, while ensuring that they can fully utilize the berth length for safe docking. This proximity underscores the limited maneuvering margins available in the immediate terminal area and demonstrates why any expansion of the terminal footprint necessitates careful adjustment of turning and berthing/unberthing paths to maintain safe operations.



**Figure 6-19: 2023 Cruise Ship Arrival Maneuver Tracks and Envelope at MCT**



**Figure 6-20: 2023 Cruise Ship Departure Maneuver Tracks and Envelope at MCT**

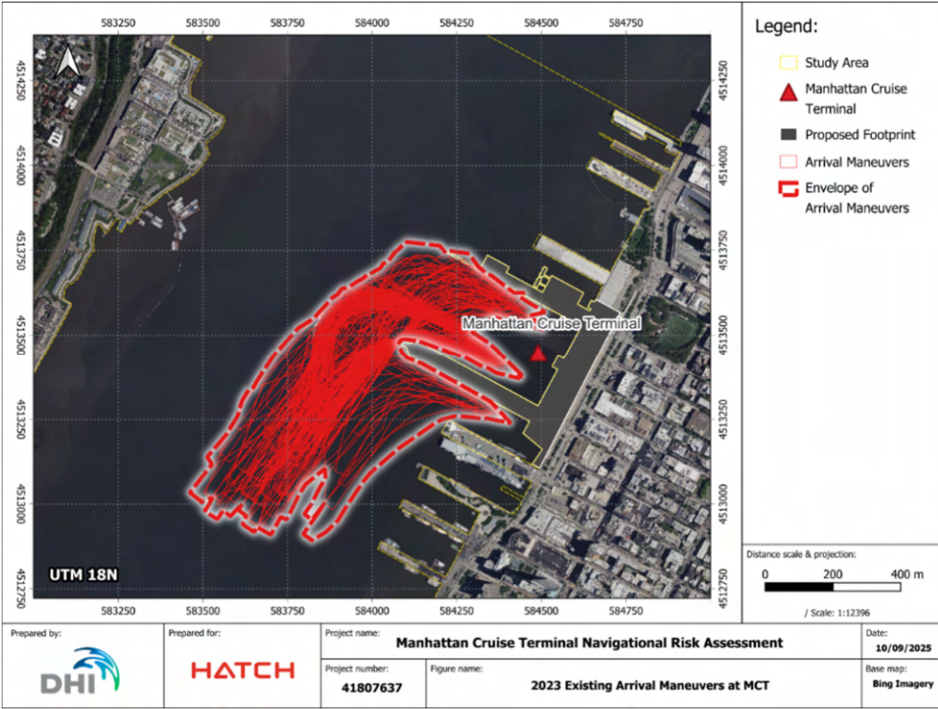
A minimal offset was applied to the swept path envelopes to account for the Proposed Project. Two updated maps show the assumed shifted arrival and departure maneuvering footprints, reflecting the minimally necessary adjustment to maintain the same level of clearance between vessel maneuvers and the terminal structures. The resulting shift is clearly visible, pushing the maneuvering envelopes slightly further into the Hudson.

It is important to note that the implications of this adjustment are not purely spatial. Maneuvers occur during discrete intervals in time, so the impact on background traffic is limited only to vessels present concurrent with arrivals or departures. The SIREN agent-based modeling (Section 8.1.2) captures these temporal interactions and provides a quantitative assessment of traffic conflicts and navigational risk associated with the shifted maneuvers.

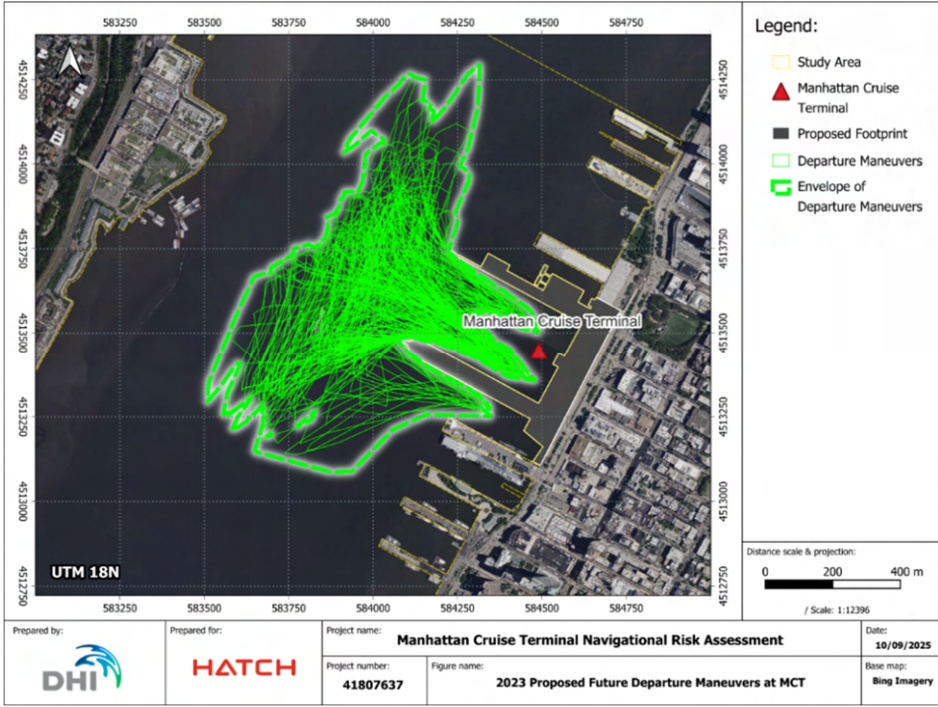
While the SIREN modeling uses existing cruise ship maneuvers shifted westward as a proxy for future operations, dedicated 2D desktop navigation simulations for the Icon Class design vessel (see Section 7), generated detailed representations of approach and departure patterns for this specific vessel. These simulations provided insights into turning requirements, tugs, pilot interactions, and safe approach/departure angles.

This same breakdown of information for 2024 vessel traffic is shown in Appendix F.

New York City Economic Development Corporation - Manhattan Cruise Terminal Master Plan  
 Navigation Safety Risk Assessment - December 19, 2025



**Figure 6-21: Proposed Future Cruise Ship Arrival Envelopes at MCT with Minimally Required Offset for Safe Clearance Based on 2023 Data**



**Figure 6-22: Proposed Future Cruise Ship Departure Envelopes at MCT with Minimally Required Offset for Safe Clearance Based on 2023 Data**

### 6.3.3 *Impacts to Vessels Frequenting Adjacent Piers to MCT*

A desktop analysis was carried out to evaluate the potential impacts of the proposed MCT expansion on vessel operations at adjacent piers. The purpose of this assessment was to identify whether vessels calling at neighboring piers would experience changes in their approach and departure geometry due to the reduced maneuvering space created by the extended terminal footprint.

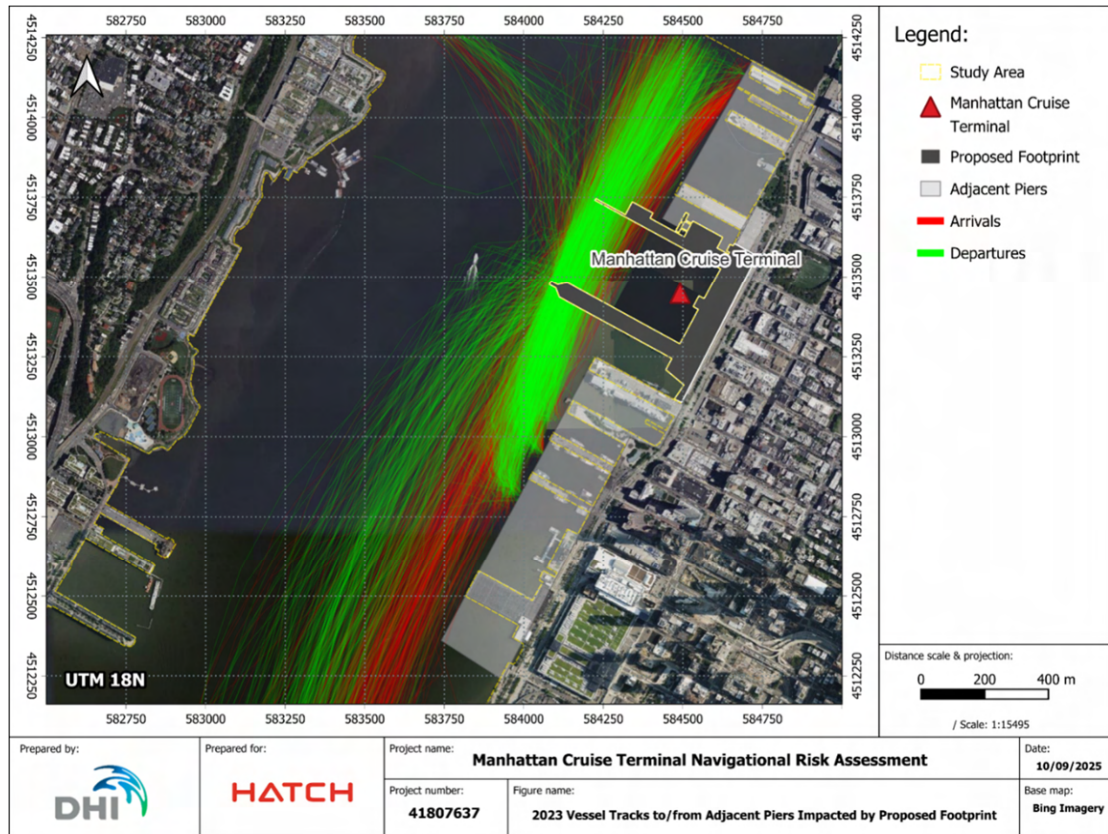
The adjacent pier analysis extended from Pier 76 in the south to Pier 99 at the northern boundary of the Study Area. These limits were selected because the piers within this range are the most likely to experience significant impacts on vessel approach and departure routes as a result of the proposed MCT expansion.

Notably, for many of these piers, the majority of vessel traffic originates from the south (or from NJ side) and does not directly interact with the proposed MCT footprint. Therefore, only those piers where the route shift would materially affect navigation patterns were included in the analysis.

Piers south of Pier 76 and piers on the New Jersey side were not included in the analysis, as the typical mid-channel transit and approach/departure routes of vessels calling at those piers are not expected to be significantly influenced by the expansion.

For the adjacent Manhattan piers between Piers 76 and 99, a focused analysis was conducted to isolate vessel traffic to and from these locations that would potentially overlap with the proposed MCT expansion zone.

This analysis focused exclusively on vessel traffic associated with adjacent piers, excluding any “through traffic” transiting past the terminal, which has already been evaluated in Section 6.3.1. The reviewed piers represent a reasonable range of nearby facilities that could experience operational impacts due to the expansion, and their positions and approach routes are depicted in the accompanying map in Figure 6-23.



**Figure 6-23: 2023 Vessel Traffic to/from Adjacent Piers Impacted by MCT Expansion**

The map illustrates the arrival and departure paths of vessels serving these adjacent piers that would overlap with the expanded terminal (excluding any arrival/departure paths not affected by the Proposed Project), which currently approach at relatively mild angles, largely aligned with the prevailing flow of traffic in the Hudson River. Under existing conditions, vessels execute their final heading adjustments very close to the ends of their respective piers, allowing efficient berthing without significant cross-river movement.

Were the Proposed Project to move forward, however, a portion of this traffic will be required to shift further out into the Hudson River to maintain safe passing distances from the expanded terminal structure. As a result, their approach and departure angles relative to their pier alignments will change, potentially requiring longer turning radii and more pronounced adjustments in course. This could lead to increased distances and durations of travel at headings offset from the predominant traffic flow, which in turn could heighten the likelihood of interaction with background or transiting vessels. This is investigated and quantified in the SIREN modelling (Section 8.1.2).

Overall, the proportion of adjacent-pier traffic that would have to adjust their approach and departure angles represents approximately 2.5% of the overall traffic frequenting these piers, signifying a small impact to their operations.

This same breakdown of information for 2024 vessel traffic is shown in Appendix I.

## 6.4 Vessel-Wake Interaction Assessment

The USACE Vessel Wake Predictor Tool (VWPT) was used to estimate wake-induced wave heights at MCT for existing conditions and for the Proposed Project. The approach combines empirical wake models with AIS data-driven inputs to develop representative scenarios for cargo, passenger, tanker and two cruise vessel classes with the Icon Class representing the design vessel and the Breakaway Plus Class representing the size of vessel currently calling at MCT. These largest sized vessels represent the greatest impacts to vessel wakes.

The results should be interpreted as conservative because the dolphins were not modelled. These could provide some level of sheltering or wave energy reduction before impacting the face of the pier structures. Given that the Proposed Project’s piers both extend the same distance into the Hudson River, the analysis was performed at a single location representative of both piers.

A short explanation of the software features, along with the results for both existing and future conditions are presented in this section.

### 6.4.1 USACE VWPT Software Introduction

According to USACE, the VWPT is a low-level exploratory tool intended to compare wake heights among vessel types rather than to provide detailed hydrodynamic simulations. The tool implements several empirical formulas reported in literature to estimate wake heights generated by passing vessels. The tool outputs the lateral distribution of wake height across the channel for a given set of vessel and channel parameters.

The following table introduces the input parameters necessary to execute the VWPT:

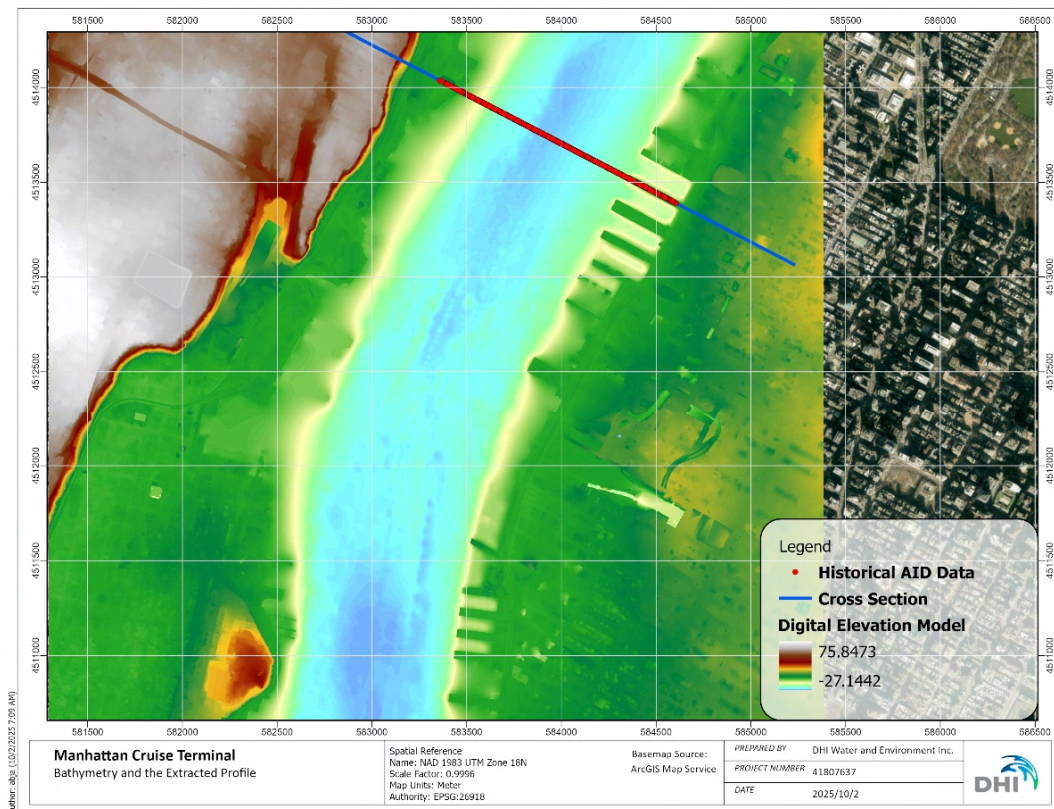
**Table 6-4: Input Parameters Required for USACE VWPT**

Parameter	Unit	Description
Vessel velocity	m s <sup>-1</sup>	Vessel speed through the water
Vessel draft	m	Vertical distance between the waterline and the keel
Vessel length	m	Overall length of the vessel
Vessel beam	m	Vessel width
Vessel mass	kg	Displacement or mass of the vessel
Vessel lateral position	m	Transverse position of the sailing line relative to the channel boundary
Channel bathymetry	m (depth below surface)	Two column dataset giving distance and elevation; positive depth indicates depth below the water surface

## 6.4.2 Bathymetric Profile

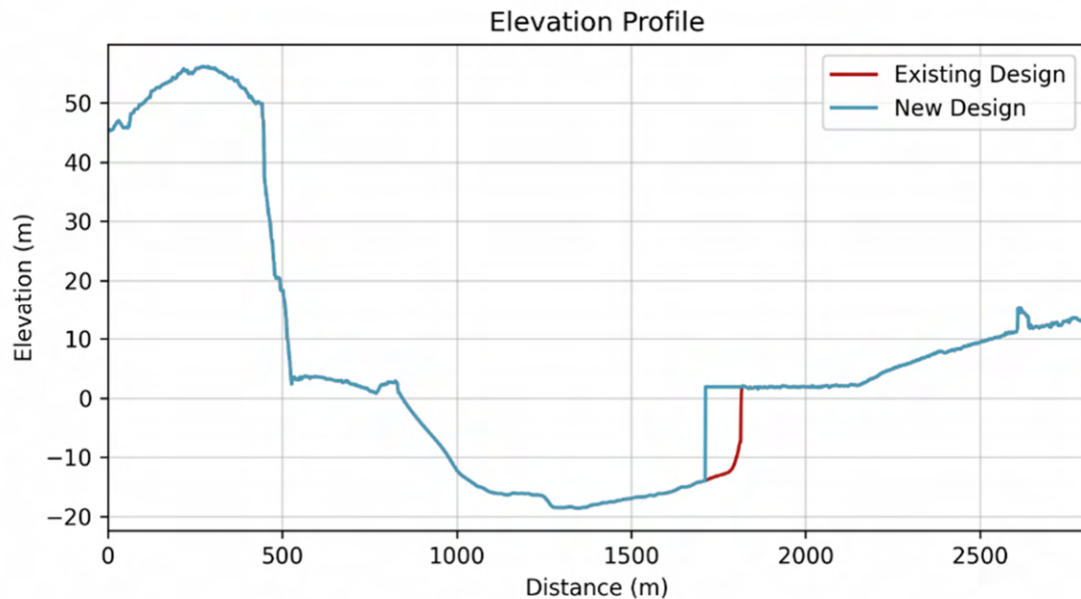
A detailed digital elevation model (DEM) of the Hudson River bed in the vicinity of MCT was developed utilizing high resolution CoNED bathymetry (CoNED (2018)), in conjunction with spring 2025 post dredge survey information at MCT provided by NYCEDC.<sup>19</sup> The cross-sectional profile used in the existing condition simulations was extracted from this DEM by slicing along a line perpendicular to MCT. For the Proposed Project, the bathymetric profile within the proposed extension was set equal to the existing pier elevation.

The proposed dolphins were not included in the updated profile. This is a conservative assumption because the mooring dolphins could attenuate wave energy and reduce wake heights. Figure 6-24 shows the DEM plan view and Figure 6-25 compares the existing and extended cross-section profiles.



**Figure 6-24: Existing Bathymetry Data Used for Vessel Wake Assessment at MCT**

<sup>19</sup> U.S. Geological Survey, *Coastal National Elevation Database (CoNED) Applications Project*, accessed October 16, 2025, <https://www.usgs.gov/special-topics/coastal-national-elevation-database-applications-project>.



**Figure 6-25: Bathymetric Cross-Section at MCT Used for Vessel Wake Analysis (existing red, proposed blue)**

### 6.4.3 Run Scenarios

Input information for passing vessels at MCT was extracted from historical AIS data. Three vessel types were identified (Cargo, Passenger, and Tanker) and the following statistics were calculated for each type:

- **Lateral Distances:** Mean distance from the existing terminal face and mean  $\pm 2$  standard deviations; these distances represent typical, near-approach and far-approach conditions.
- **Speeds:** Maximum and median vessel speeds for each type.
- **Vessel Dimensions:** The length, width, and draft as reported in the AIS to subsequently estimate vessel displacement using representative block coefficients from PIANC (2014)<sup>20</sup>.

Combining the three lateral distances and two speeds yields six scenarios per vessel type, a total of 18 scenarios. To account for the largest cruise vessels expected at the Proposed Project, two additional vessel classes (the Icon Class representing the design vessel and the Breakaway Plus Class representing the size of vessel currently calling at MCT) were defined. Each of these classes was assigned representative max speeds and near-approach lateral distances according to typical cruise ship movements arriving at MCT. Thus, there were a total of 20 scenarios examined.

<sup>20</sup> PIANC Secrétariat Général, *Harbour Approach Channels: Design Guidelines*, PIANC Report No. 121 (Brussels: PIANC Secrétariat Général, January 2014).

Each of the scenarios was driven by the historical AIS data to be reflective of actual conditions. For example, for the mean passing distance runs, the median and maximum sized vessels were chosen from the list of vessels passing at these specific distances, and the speeds used in the vessel wake assessment are reflective of the actual speeds travelled by these vessel sizes. The median speeds were chosen based on the speed that median-sized vessels travelled at each distance interval, and the maximum speeds were chosen based on the speed that the maximum-sized vessels travelled at each distance interval.

This reduces the chance of developing overly conservative or under-conservative run conditions not reflective of actual traffic conditions. Since arriving cruise ships typically approach MCT in very close proximity and under a tight band of reduced speed conditions (refer to Figure 6-15), the Icon Class and Breakaway Plus Class simulations were only executed using their maximum speeds at this near approach location.

For the Proposed Project, the distances were calculated from the edge of the extended pier structure. For cases where the reduced distance crosses the dolphins, the distance was considered to include a one-vessel-width buffer beyond the end of the dolphins. Table 6-5 presents the summary of the scenarios.

This analysis provides the vessel wake height associated with each design scenario at both the existing and proposed terminal configurations, allowing for a quantitative assessment of how conditions will change.

It is important to note that this is a high-level vessel wake assessment tool. It does not include either sea-waves generated by local wind conditions, nor does it include cumulative effects of multiple vessels or reflections from any adjacent structures or shorelines. This analysis also assumes that vessels not impacted by the Proposed Project would have a reduced clearance (and thus increased vessel wake) at MCT. This is considered conservative to the contrary scenario where all vessels may shift their routes to maintain the same level of passing distance to the future terminal as they have at the existing terminal.

**Table 6-5: Design Scenarios Executed for the Vessel Wake Assessment**

Run ID	Type	Distance to the Existing Terminal (m)	Distance to the Extended Terminal (m)	Length (m)	Width (m)	Draft (m)	Displacement (tonne)	Speed (m/s)	Water Level	Description
1	Cargo	614	509	50.00	10.00	2.50	1,025	3.94	MSL	Far approach, median sized vessel and speed
2	Cargo	143	115	50.00	10.00	2.50	1,025	4.00	MSL	Close approach, median sized vessel and speed
3	Cargo	378	274	177.00	28.00	7.60	30,886	5.72	MSL	Mean approach, median sized vessel and speed
4	Cargo	614	509	198.00	32.00	6.80	35,330	5.78	MSL	Far approach, maximum sized vessel and speed
5	Cargo	143	133	177.00	28.00	6.10	24,790	4.78	MSL	Close approach, maximum sized vessel and speed
6	Cargo	378	274	200.00	33.00	8.70	47,084	5.90	MSL	Mean approach, maximum sized vessel and speed
7	Passenger	767	663	27.00	8.00	2.00	310	6.35	MSL	Far approach, median sized vessel and speed
8	Passenger	229	124	30.00	9.00	1.60	310	6.40	MSL	Close approach, median sized vessel and speed
9	Passenger	498	393	30.00	8.00	2.00	344	6.49	MSL	Mean approach, median sized vessel and speed
10	Passenger	767	663	65.00	20.00	4.00	3,731	1.63	MSL	Far approach, maximum sized vessel and speed
11	Passenger	229	146	334.00	41.00	8.70	85,481	1.63	MSL	Close approach, maximum sized vessel and speed
12	Passenger	498	393	334.00	41.00	8.70	85,481	1.17	MSL	Mean approach, maximum sized vessel and speed
13	Tanker	761	657	106.00	15.00	5.00	6,926	5.84	MSL	Far approach, median sized vessel and speed
14	Tanker	104	112	23.00	7.00	3.60	505	3.84	MSL	Close approach, median sized vessel and speed
15	Tanker	433	328	106.00	15.00	5.00	6,926	6.01	MSL	Mean approach, median sized vessel and speed
16	Tanker	761	657	106.00	15.00	5.00	6,926	6.58	MSL	Far approach, maximum sized vessel and speed

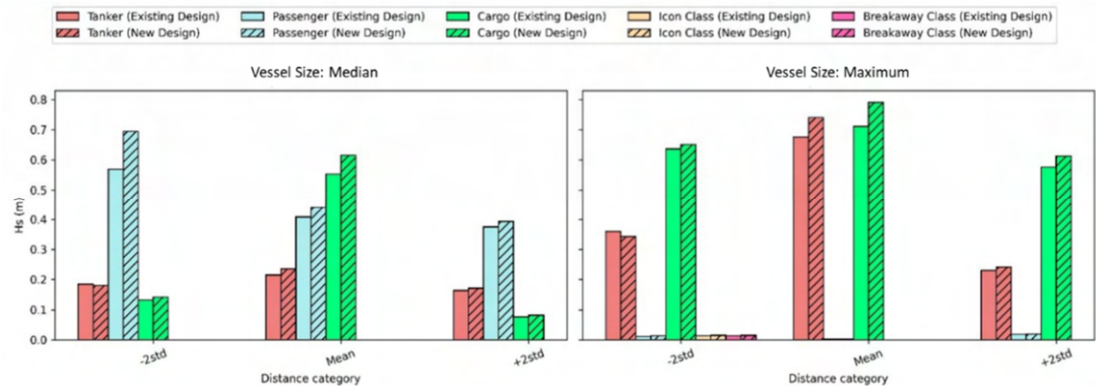
Run ID	Type	Distance to the Existing Terminal (m)	Distance to the Extended Terminal (m)	Length (m)	Width (m)	Draft (m)	Displacement (tonne)	Speed (m/s)	Water Level	Description
17	Tanker	104	120	106.00	15.00	5.00	6,926	6.07	MSL	Close approach, maximum sized vessel and speed
18	Tanker	433	328	195.00	32.00	8.10	44,036	6.51	MSL	Mean approach, maximum sized vessel and speed
19	Icon Class	229	153	364.75	48.77	9.25	118,062	1.63	MSL	Close approach, Icon Class Vessel at typical arrival speed
20	Breakaway Plus Class	229	153	333.44	48.13	8.70	100,179	1.63	MSL	Close approach, Breakaway Plus Vessel at typical arrival speed

## 6.4.4 Results

VWPT simulations were run for each scenario using the existing channel profile and the extended profile. For each run, wake height (expressed as significant wave height, Hs) was extracted at the location of the existing terminal face and at the proposed extension face. Significant wave height refers to the average height of the highest one-third of waves in a given sea state. The results are presented in Table 6-6 and depicted graphically in Figure 6-26.

**Table 6-6: Vessel Wake Analysis Results for Existing and Proposed Conditions at MCT**

Run ID	Vessel Type	Distance Condition	Speed Condition	Hs - Existing Design (m)	Hs - New Design (m)
1	Cargo	+2std	Median	0.08	0.08
2	Cargo	-2std	Median	0.13	0.14
3	Cargo	Mean	Median	0.55	0.61
4	Cargo	+2std	Max	0.58	0.61
5	Cargo	-2std	Max	0.64	0.65
6	Cargo	Mean	Max	0.71	0.79
7	Passenger	+2std	Median	0.37	0.39
8	Passenger	-2std	Median	0.57	0.69
9	Passenger	Mean	Median	0.41	0.44
10	Passenger	+2std	Max	0.02	0.02
11	Passenger	-2std	Max	0.01	0.01
12	Passenger	Mean	Max	0.00	0.00
13	Tanker	+2std	Median	0.16	0.17
14	Tanker	-2std	Median	0.18	0.18
15	Tanker	Mean	Median	0.22	0.24
16	Tanker	+2std	Max	0.23	0.24
17	Tanker	-2std	Max	0.36	0.34
18	Tanker	Mean	Max	0.68	0.74
19	Icon Class	-2std	Max	0.01	0.02
20	Breakaway Class	-2std	Max	0.01	0.01



**Figure 6-26: Vessel Wake Analysis Results for Existing and Proposed Conditions at MCT**

The preliminary results indicate that extending the pier will modestly increase the exposure of the terminal to vessel-generated wake. This is expected because the extended structure protrudes further into the navigable channel, reducing the lateral distance to passing vessels. The magnitude of the increase depends on vessel type, speed, and distance.

As expected, wake height increases with vessel speed and decreases with distance from the sailing line. However, the largest wave heights do not always occur at the closest passes. According to AIS data, vessels tend to slow down substantially when maneuvering very close to the terminal, so the near-approach (“-2 std”) scenarios often have lower speeds and, consequently, smaller wakes than the “mean” distance scenarios.

For cargo and tanker vessels, the highest wakes are generated at the mean lateral distance when speeds remain relatively high. The far-approach (“+2 std”) scenarios consistently produce the lowest wakes because vessels are both farther away and, in some cases slower, possibly representing a slow down to approach a pier on the New Jersey side.

In most cases, relocating the prediction point further into the Hudson River increased the calculated wave height. The increase is modest for low-wake scenarios (e.g., small passenger vessels at slow speed) but becomes more significant when the baseline wake is large. For cargo vessels at the mean distance and maximum speed, the extension raised the predicted wave height by roughly 0.08 m. Similar increases (0.06–0.07 m) occur for tanker vessels in their controlling scenarios.

There is one exception: in the tanker scenarios with the closest distance, the wave height for the extended design is slightly lower. This is because the assumed sailing line for those cases was offset by an additional vessel-width buffer to prevent crossing over the dolphins, effectively keeping the ship farther from the prediction point (the face of the pier structure) and reducing the computed wake height.

It should be noted that the VWPT does not account for complex hydrodynamic processes such as wave shoaling, refraction, or wave–structure interaction.

In general, the results predict a modest increase in vessel wake effects at MCT under the Proposed Project.

## 6.5 Analysis of Temporary Navigation Impacts

This portion of the report focuses on the additional navigation impacts associated with the temporary demolition and construction efforts planned for the Proposed Project. For this analysis, the impact assessment will focus exclusively on project phases where vessel navigation may be impacted and will exclude phases in which the work is conducted entirely on land. For the phases of construction that are exclusively on land operations, it is expected that navigation would not be impacted (unless in-water security zones are kept in place), but that slip availability and operations at MCT would be similar to the preceding phase.

The demolition and construction activities relevant to potentially increased navigation impacts are divided into five major phase groups: Phase 1a, Phase 1b, Phase 2a, Phase 3/4a, and Phase 4b. The phases are grouped based on whether their sub-phase schedules overlap in the proposed master Gantt chart for the Proposed Project activities.

The following describes the potential risks introduced throughout the demolition and construction phases, outlines the five major phase groups and their timelines, and summarizes the information in a cohesive summary table. Additional simplified maps are provided for each phase group to illustrate the proposed work. The key takeaway from this assessment is the qualitative impact level assigned to each phase, based on the combination of several potential risk factors.

For this analysis, it is assumed that a security zone would be established around in-water works and presence of construction vessels in order to maintain safe clearances. Based on AIS data (and knowledge from MCT) only Pier 88 South, Pier 88 North, and Pier 90 North are currently utilized by cruise ship operations, as the remaining slips at MCT do not have the on-land infrastructure required to accommodate cruise ships and passengers.

### 6.5.1 Temporary Impact Factors Considered for Construction Period

Although they are temporary, there are several additional impacts that are introduced during the demolition and construction phases of the Proposed Project. The following factors considered in this analysis are:

- **Construction Vessels:** presence of construction vessels may be required for several phases of this project. Aside from the obvious increase in overall traffic, the construction vessels introduce additional concerns, such as maneuverability. Additional safety and security zones are assumed to be established to prevent collisions when construction vessels are in use.
- **Berth Availability:** throughout the project, the number of slips available for cruise ship use fluctuates. As piers are demolished, slip availability can be reduced, impacting overall capacity and operations at MCT. Cruise ships are expected to coordinate docking and disembarking, causing impacts to traffic at remaining operational berths.

- **Land and Water Coordination:** several phases of this project involve construction and/or demolition both in the Hudson River and on land. Berth availability relies on successful completion of both infrastructure components. While land construction may not directly impact navigation, it is essential that land infrastructure is operational and construction on land does not impede arrivals or departures of cruise ships and passengers at the remaining berths.
- **Reduced Navigation Space:** with the introduction of construction vessels and security zones during both demolition and construction, there is less space within the channel and inside berth basins. The most extensive reduction in navigation space in the Hudson River happens during the phases where the North and South Piers are being constructed. This will require traffic to be relocated further into the Hudson. This is likely to increase potential vessel interactions within the channel, especially as cruise ships attempt to maneuver around potential security zones.

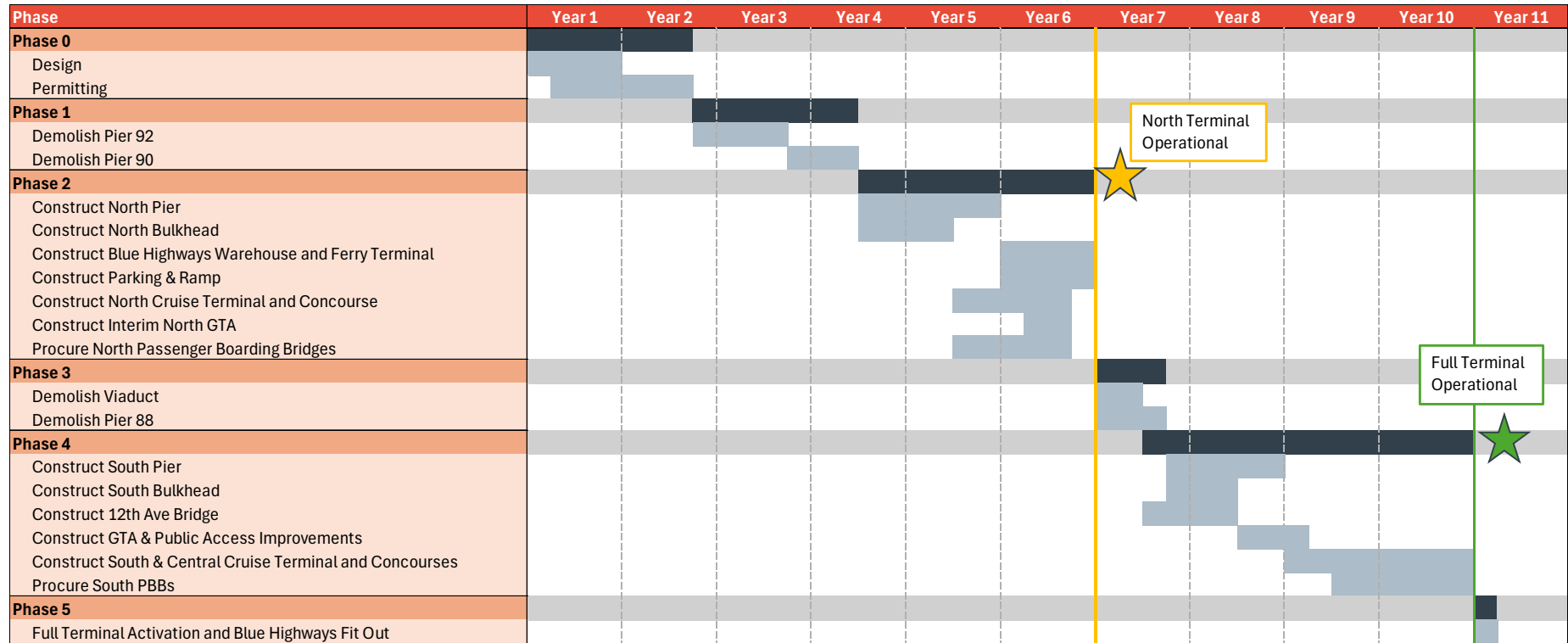
The relative impact due to each project phase was qualitatively developed through a combination of impacts from presence of construction vessels and associated recommended security zones, berth availability and overall operations at MCT, and the presence of land and/or water project activities that may reduce navigation and maneuvering space both in the Hudson River (background traffic) and at MCT (cruise ships).

## **6.5.2 Project Construction Timeline and Associated Phase Impacts**

The entire Proposed Project is expected to take 10 years, including early project design and permitting phases through to the final design and for the terminal to become fully operational. Once the terminal is activated, an additional year will be required to complete the fit out of the Blue Highways terminal.

The master plan Gantt chart depicted in Figure 6-27 outlines all phases and are considered for assessing potential temporary impacts to vessel traffic and MCT operations. As a note, Phase 1 has been split up into Phase 1a and Phase 1b to delineate the demolition of Piers 92 and 90 for assessment purposes only. The order in which they are completed is subject to change.

**Figure 6-27: Proposed Timeline Gantt Chart of MCT Expansion Operations**



6.5.2.1 Phase 1a – Demolish Pier 92

Phase 1a involves the demolition of Pier 92, likely requiring the use of construction vessels. The major impacts during this period include reduced space for berthing and unberthing operations at Pier 90 North and a security zone extending into the channel. Background and cruise ship traffic will experience reduced navigation space due to demolition activities, the presence of construction vessels, and the establishment of a security zone. Maneuvering space for berth 90N will be limited, but all three berths currently utilized by MCT will remain open for cruise ships and Pier 92 is unusable in its current state. This phase and associated impacts are depicted in Figure 6-28.

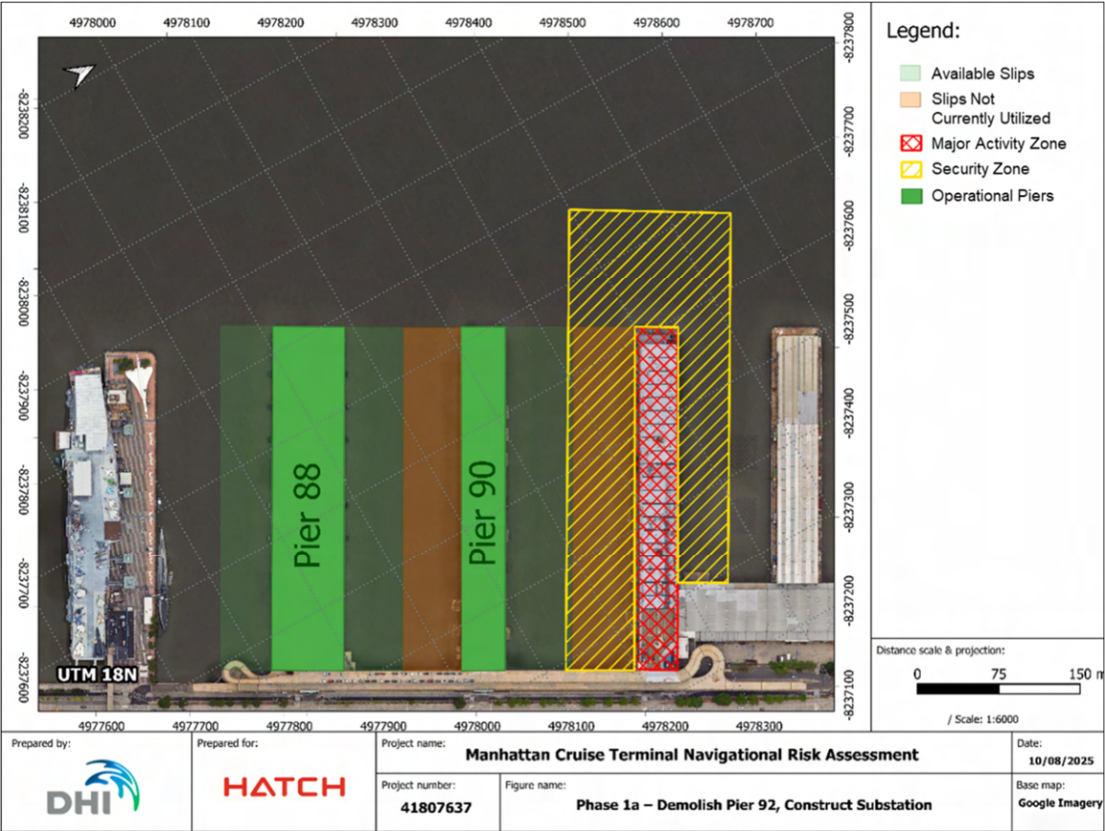


Figure 6-28: Temporary Navigation Impacts During Phase 1a

6.5.2.2 Phase 1b – Demolish Pier 90

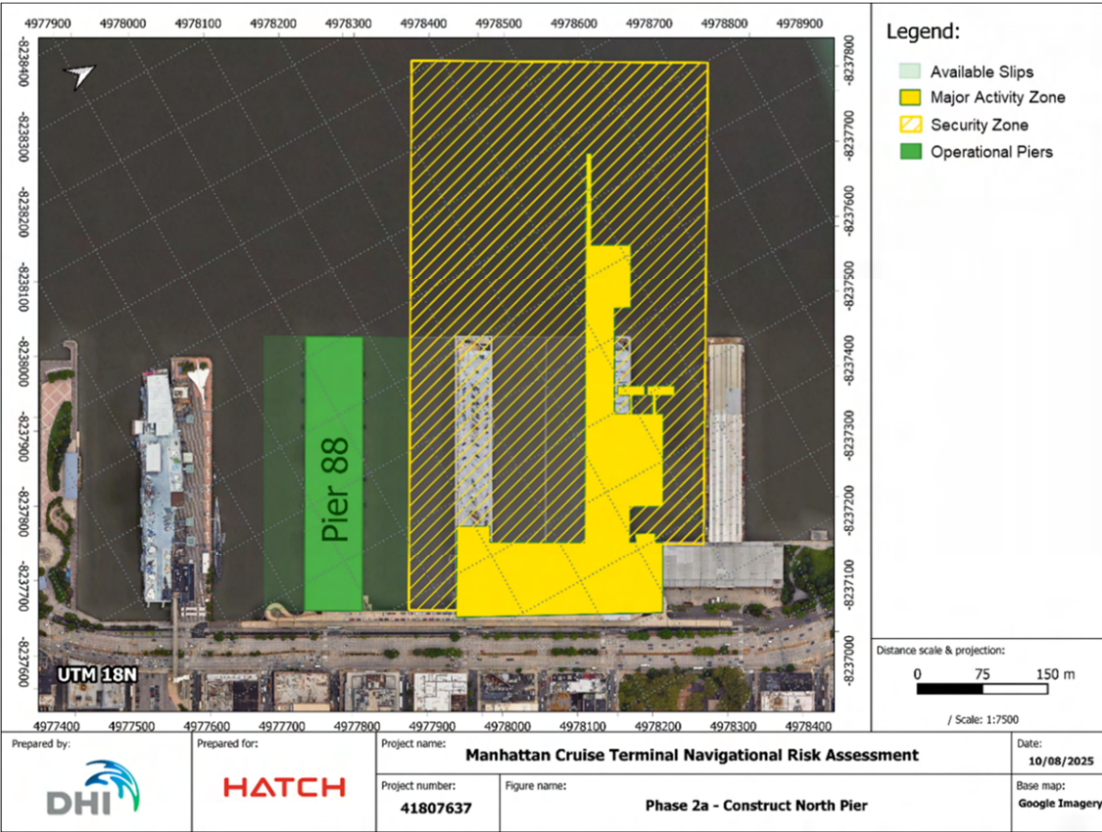
Phase 1b covers the demolition of Pier 90, which will also likely require construction vessels. This phase will result in the loss of the berth at Pier 90 North, and reducing available maneuvering space for berth Pier 88 North. Background and cruise ship traffic will be affected by reduced navigation space and fewer berths. Coordination of ship allocations at berths Pier 88 North and Pier 88 South will be necessary. Two berths will remain open for cruise ships during this phase. This phase and associated impacts are depicted in Figure 6-29.



Figure 6-29: Temporary Navigation Impacts During Phase 1b

**6.5.2.3 Phase 2 – Construct North Pier, Bulkheads, and Uplands**

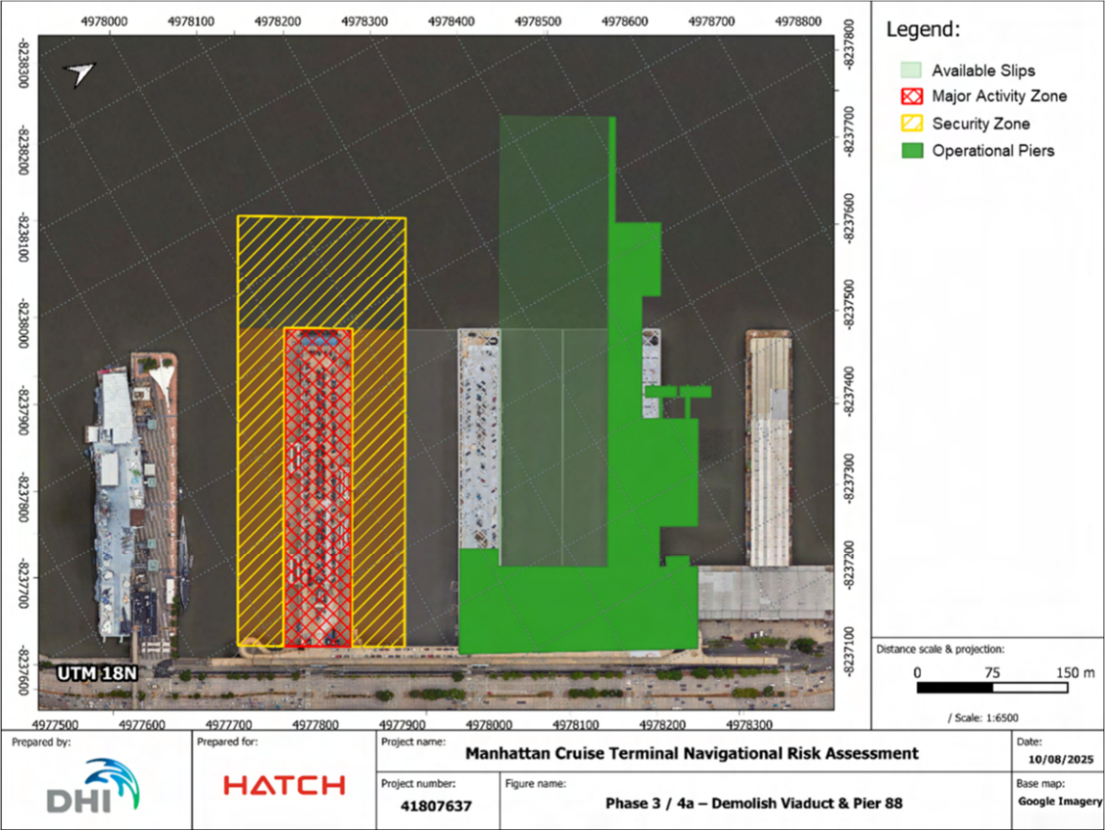
Phase 2 focuses on the construction of the North Pier, including bulkhead and upland work, with construction vessels potentially active throughout. Only two berths will remain open to vessel traffic (Piers 88 North and 88 South), and navigation space will be limited due to the presence of construction equipment. Background and cruise ship traffic will continue to be affected by reduced maneuvering areas and berth availability. Coordination of use between the two remaining berths will be essential. This phase and associated impacts are depicted in Figure 6-30.



**Figure 6-30: Temporary Navigation Impacts During Phase 2**

**6.5.2.4 Phases 3 – Demolish Viaduct and Pier 88**

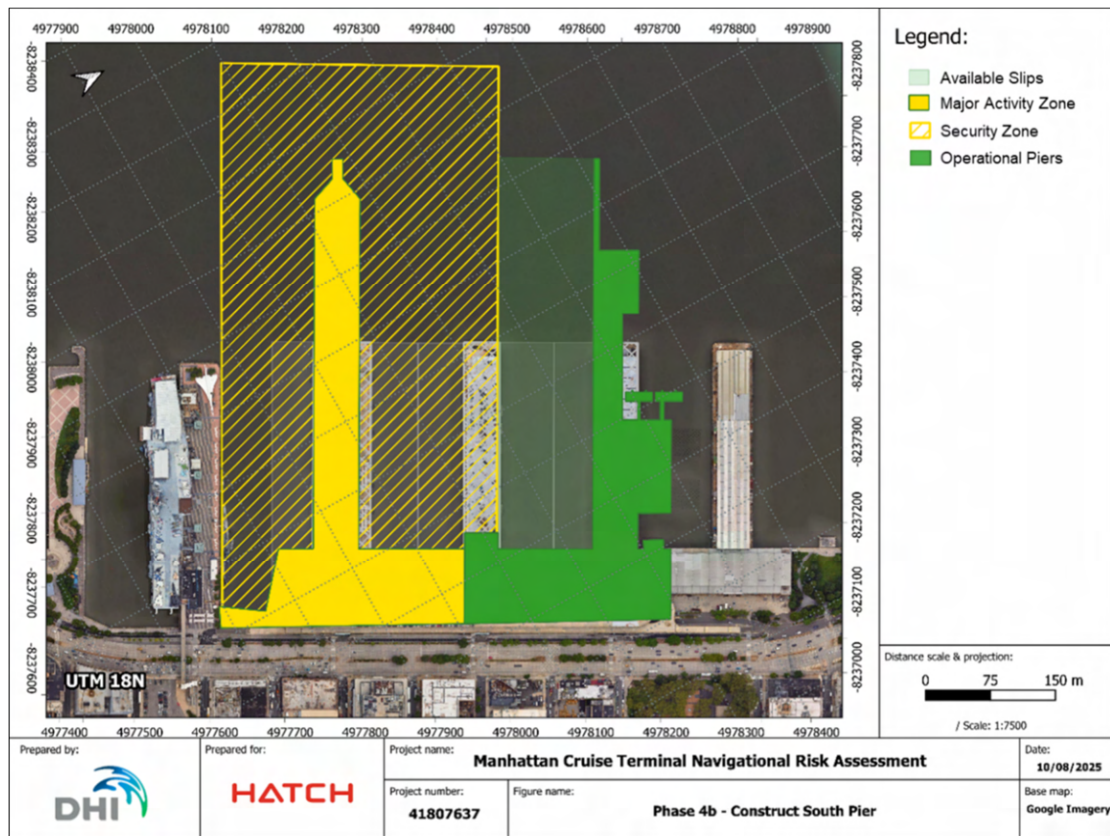
Phase 3 entails demolition of the Viaduct and Pier 88. Construction vessels are expected to be required during this period, representing waterway obstruction. Berths at Piers 88 North and 88 South will be unavailable, and only the new North Pier will remain open for cruise activity. Navigation space will be reduced due to demolition activities, and only one berth will remain open, now available for larger cruise ships. This phase and associated impacts are depicted in Figure 6-31.



**Figure 6-31: Temporary Navigation Impacts During Phases 3**

### 6.5.2.5 Phase 4 – Construct South Pier, Bulkheads, and Uplands

Phase 4 involves construction of the South Pier, along with bulkheads and upland development. Construction vessels will likely be active, further reducing available navigation and maneuvering space. Only the North Pier will remain operational for cruise ships during this period, and coordination of vessel arrivals and departures will be required. Given the restricted navigation space, additional construction activity, and limited berthing availability, this phase is expected to have the highest overall impact level. Compared to the previous phase, this represents a higher impact level because although MCT operations will remain similar with only one open berth, the impact to background traffic will be largest because of the South Pier construction footprint and associated security zone. This represents the period of time where both MCT operations and background traffic has the greatest potential impact. This phase and associated impacts are depicted in Figure 6-32.



**Figure 6-32: Temporary Navigation Impacts During Phase 4**

### 6.5.3 ***Summary Table of Temporary Impacts to Navigation***

The demolition and construction phases and their associated risks are organized into the following table. Each phase has an assigned qualitative impact level based on the combined effects of several risk factors.

For example, phases which propose the smallest temporary impacts to background traffic and operations at MCT (Phase 1a) are considered relatively low impact. Phases which propose higher temporary impacts to background traffic and reduced operations at MCT (Phases 1b, 2, and 3) are considered relatively medium. Phases that propose the highest level of temporary impact to background traffic and operations at MCT (Phase 4) are considered relatively high.

The temporary impacts expected by each of the project phases are summarized in Table 6-7.

**Table 6-7: Summary Table of Temporary Impacts to Navigation**

Phase	Brief Description	Approx. Duration	In Water/ On Land	Construction Vessels	Major Impacts	Traffic Impacted	Impact to Background Traffic	Impact to Cruise Ships	Slips Open at MCT	Impact Level (L/M/H)
1a	Demolish Pier 92, Construct Substation	280 days	Both	Yes	<ul style="list-style-type: none"> <li>Reduced space at 90N</li> <li>Security zone extending into channel</li> </ul>	<ul style="list-style-type: none"> <li>Background traffic</li> <li>Cruise ships to 90N</li> <li></li> </ul>	Reduced space due to security zone	Reduced maneuvering space at 90N	3	L
1b	Demolish Pier 90	180 days	Both	Yes	<ul style="list-style-type: none"> <li>Loss of berth 90N/S,</li> <li>Reduced navigation space for 88N</li> <li>Security zone extending into channel</li> </ul>	<ul style="list-style-type: none"> <li>Background traffic</li> <li>Cruise ships to 90N</li> <li>Cruise ships to 88N</li> <li>Other vessels using 90N/S</li> </ul>	Reduced space due to security zone	Loss of 90N Reduced navigation space for 88N Coordination required for reduced berths	2	M
2	Construct North Pier, Bulkheads/ Uplands	400 days	Both	Yes	<ul style="list-style-type: none"> <li>Loss of berth 90N/S, 92N/S</li> <li>Reduced navigation space for 88N</li> <li>Largest security zone extending into channel</li> </ul>	<ul style="list-style-type: none"> <li>Background traffic</li> <li>Cruise ships to 90N</li> <li>Cruise ships to 88N</li> <li>Other vessels using 90N/S and 92N/S</li> </ul>	<ul style="list-style-type: none"> <li>Maximum reduced space due to security zone</li> <li>Can't use 90N/S</li> </ul>	Loss of 90N Reduced navigation space for 88N Coordination required for reduced berths	2	M
3	Demolish Viaduct & Pier 88	240 days	Both	Yes	<ul style="list-style-type: none"> <li>Only North Pier open</li> <li>Loss of berths 88N/S</li> </ul>	<ul style="list-style-type: none"> <li>Background traffic</li> <li>Cruise ships to 88N/S</li> </ul>	<ul style="list-style-type: none"> <li>Reduced space due to security zone</li> <li>Can't use 88N/S</li> </ul>	Only North Pier Open Reduced navigation	1	M

Phase	Brief Description	Approx. Duration	In Water/ On Land	Construction Vessels	Major Impacts	Traffic Impacted	Impact to Background Traffic	Impact to Cruise Ships	Slips Open at MCT	Impact Level (L/M/H)
					<ul style="list-style-type: none"> <li>Security zone extending into channel</li> </ul>	<ul style="list-style-type: none"> <li>Cruise ships to North Pier</li> <li>Other vessels using 88N/S</li> </ul>		space for North Pier Coordinated usage of North Pier		
4	Construct South Pier, Bulkheads/ Uplands	400 days	Both	Yes	<ul style="list-style-type: none"> <li>Only North Pier open</li> <li>Largest security zone extending into channel</li> </ul>	<ul style="list-style-type: none"> <li>Background traffic</li> <li>Cruise ships to North Pier</li> <li>Other vessels using North Pier</li> </ul>	<ul style="list-style-type: none"> <li>Maximum reduced space due to security zone</li> <li>Reduced maneuvering space to North Pier</li> </ul>	Only North Pier Open Reduced navigation space for North Pier Coordinated Usage of North Pier	1	H

For the purposes of this analysis, a security zone of 100 yards was depicted for illustrative purposes. The exact extent of this security zone should be determined through further investigation of the necessary construction vessels and to limit the extent as much as possible between berths to maintain MCT operations during demolition and construction.

A recommended security zone and lessons learned may be determined through communication with stakeholders related to the Gateway Development Commission's Hudson River Ground Stabilization Project, where similar traffic avoidance is necessary at the stationed cofferdam.<sup>21</sup>

## 7. Desktop Navigation Simulations

To assess the feasibility and safety of cruise ship operations at the Proposed Project, a series of desktop navigation simulations (DNS) were undertaken using an Icon Class Cruise Ship as the representative design vessel. These studies were performed by a qualified master mariner to evaluate the maneuvering characteristics, approach and departure feasibility, and required clearances under a range of representative and upper-limit environmental conditions experienced at MCT.

The objective in this 2D desktop navigation simulation study was to:

- Identify potential concerns, if any, on the approaches to berthing and unberthing the largest cruise ship anticipated to utilize the new terminal.
- Validate the feasibility of maneuvering such ships to and from the berth in upper limit scenarios with typical maximum tidal current and wind conditions, as well as two emergency conditions.

The new terminal layout associated with the Proposed Project was used for the desktop navigation simulations. In the Proposed Project, Pier 88 would be replaced with the South Pier 90 and Pier 92 would be replaced with the North Pier. For ease of reference in this report, the nomenclature and respective berths of Pier 88 and Pier 92 will continue to be used.

### 7.1 2D Desktop Navigation Simulator Set-Up

The 2D desktop navigation simulation (DNS) runs were conducted using a FORCE Technology SIMFLEX desktop simulator in real time. Figure 7-1 shows the SIMFLEX desktop simulator used for the study:

---

<sup>21</sup> Gateway Development Commission, *Gateway Development Commission's Hudson Tunnel Project*, accessed October 16, 2025, <https://www.gatewayprogram.org/hudson-river-ground-stabilization-project.html>.



**Figure 7-1: FORCE Technology 2D Desktop Simulator**

The 2D simulator features a top-down view. To run the simulation, the operator first inputs environmental conditions (e.g., wind and tidal current) as specified by the run matrix and then performs the simulation run and prints the results.

During the simulation runs, the simulator is controlled by the Captain with a mock-up of a navigation bridge. The controls included two azimuth thruster levers that independently rotate the modeled thrusters for precise speed and direction. The Captain operates the simulator while facing a screen that displays a “Bird’s eye” view of the study area.

For the navigation study, all the arrival simulation runs start with the cruise ship in the Hudson River approximately 0.4 nautical miles south-west of Pier 88.

All simulation runs terminate when the objective of the run has been met (e.g. upon successful berthing, or upon successful transition to departure route after unberthing). All simulation scenario runs were undertaken as far as practicable according to existing pilotage practices.

The study identifies potential concerns, if any, on the ship berthing and unberthing at the North Pier and South Pier in a combination of winds and tidal current conditions.

All simulation runs are logged electronically to enable real time re-play of what happened during the runs. This includes time series of a large number of parameters: speed over ground and through the water, rudder angle, propeller revolutions, bow thruster power applied, etc. This allows for later investigation of all runs in detail.

## 7.2 Design Vessel Specifications

The Icon Class cruise ship is one of the largest passenger vessels currently in operation and serves as the design vessel (the “Design Vessel”) for evaluating terminal layout and maneuvering feasibility at the Proposed Project site. Presently, the largest cruise ships typically call at major cruise hubs in Florida and the U.S. Gulf. The Icon Class was chosen as the design vessel for this study because it is anticipated that the largest cruise vessels will continue serving major hubs in the U.S. Gulf and Florida. Meanwhile, the next-largest classes—such as the Icon Class—are expected to call at MCT in the future. Key particulars of the vessel used in the simulations are outlined in the tables below.

The DNS represents a feasibility study of an Icon Class-sized vessel berthing at the redeveloped MCT. As such, the model of the design vessel used in this study is not intended to be a perfect representation of an Icon Class ship, but was built using DNV Class registry information, publicly available data from Royal Caribbean Cruise Lines (RCCL), and other industry source material to closely represent the design vessel expected to call at MCT in the future. Any future detailed design stages for the redevelopment of MCT would require full bridge mission simulations supported by cruise ship operators, such as RCCL.

**Table 7-1: List of Icon Class Dimension Specifications**

Principal Dimension	Meters	Feet
Length Overall	364.75	1,196.70
Length Between Perpendiculars	351.31	1,152.58
Breadth (Extreme)	48.77	160.01
Depth	22.40	73.49
Draft	9.25	30.35
Frontal Windage Area	3,000 m <sup>2</sup>	32,300 ft <sup>2</sup>
Lateral Windage Area	16,000 m <sup>2</sup>	172,200 ft <sup>2</sup>

**Table 7-2: List of Icon Class Tonnage Specifications**

Principal Dimension	Metric Tonnes
Gross Tonnage (ITC 69)	248,663
Net Tonnage (ITC 69)	307,895
Deadweight Tonnage	21,513

**Table 7-3: List of Icon Class Propulsion Characteristics**

Propulsion	Number	Make	Model	Power (kW each)	Power (hp each)
Main Engine	3	Wartsila	14V46DF	16,030	21,790
Main Generator Engines	3	Wartsila	12V46DF	13,740	18,680
Main Propulsion	3	ABB Azipod		20,000	27,000
Bow Thrusters	5	Wartsila	WTT-45 CP	4,800	6,400

### 7.3 Desktop Navigation Simulation Run Conditions

A matrix of simulation runs was developed to represent the upper range of operational and environmental conditions experienced at MCT, according to historical wind and tidal current records. Each scenario combined representative tidal current directions and magnitudes with the predominant wind speed and directions observed in the historical record. The upper-limit conditions were selected to reflect the realistic maximums under which vessel maneuvers would still be expected to occur safely, and remained consistent across the board to illustrate feasibility.

In addition to standard approach and departure scenarios, two emergency simulations were conducted to assess ship response and control under gust-induced disturbances: one simulating a wind gust during the early stage of departure, and another during the final approach phase of arrival. These cases provided valuable insights into the vessel's reserve maneuvering capability and any necessity for tug assistance under extreme but credible conditions according to historical trends.

The full list of run conditions executed for the desktop navigation simulations are found in Table 7-4.

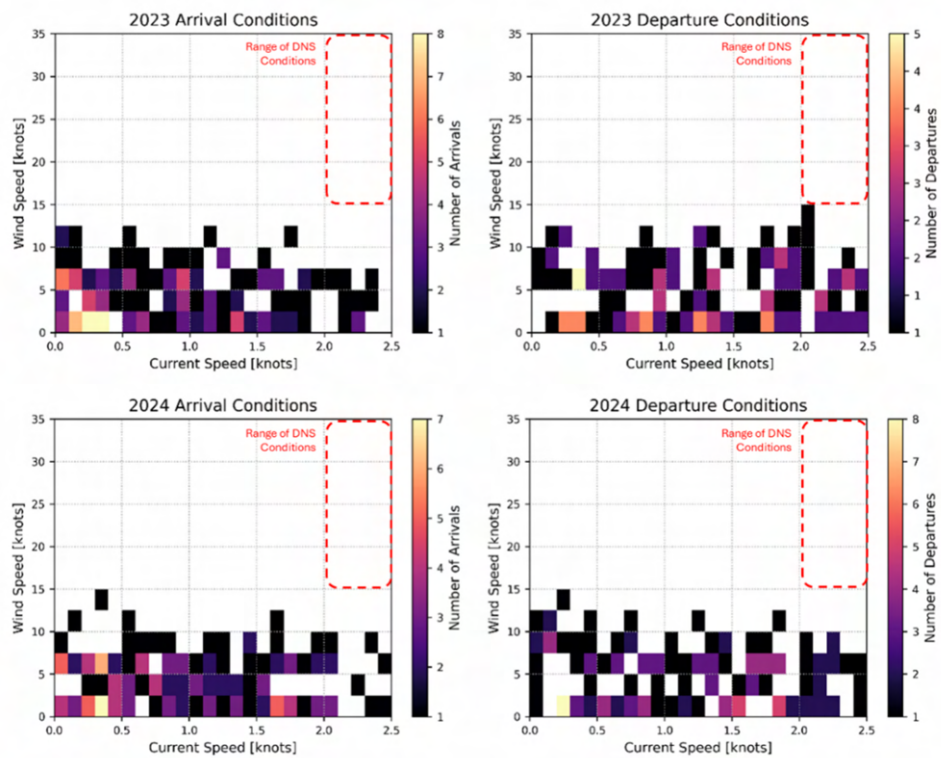
**Table 7-4: Desktop Navigation Simulation Run Matrix**

Run No.	Status	Berth	Aspect	Wind Velocity	Current Velocity	Category	Description
1	Arrival	88N	Bow First	NW x 25 kts.	Ebb x 2.5 kts.	Extreme Most Common	Extreme NW winds + ebb tide arrival @ 88N
2	Departure	88N	Stern First	NW x 25 kts.	Ebb x 2.5 kts.	Extreme Most Common	Extreme NW winds + ebb tide departure @ 88N
3	Arrival	88N	Bow First	NW x 25 kts.	Flood x 2.0 kts.	Extreme Most Common	Extreme NW winds + flood tide arrival @ 88N
4	Departure	88N	Stern First	NW x 25 kts.	Flood x 2.0 kts.	Extreme Most Common	Extreme NW winds + flood tide departure @ 88N
5	Arrival	92S	Stern First	NW x 25 kts.	Ebb x 2.5 kts.	Extreme Most Common	Extreme NW winds + ebb tide arrival @ 92S
6	Arrival	92S	Bow First	NE x 15 kts.	Ebb x 2.5 kts.	Extreme Less Common	Extreme NE winds + ebb tide arrival @ 92S - NE winds and ebb tide combine forcing
7	Arrival	92S	Bow First	NW x 25 kts.	Flood x 2.0 kts.	Extreme Most Common	Extreme NW winds + flood tide arrival @ 92S
8	Departure	92S	Stern First	NW x 25 kts.	Flood x 2.0 kts.	Extreme Most Common	Extreme NW winds + flood tide departure @ 92S
9	Arrival	88N	Bow First	SW x 25 kts.	Flood x 2.0 kts.	Extreme Less Common	Extreme SW winds + flood tide arrival @ 88N - SW winds and flood tide combine forcing
10	Departure	88N	Stern First	SW x 25 kts.	Flood x 2.0 kts.	Extreme Less Common	Extreme SW winds + flood tide departure @ 88N - SW winds and flood tide combine forcing

Run No.	Status	Berth	Aspect	Wind Velocity	Current Velocity	Category	Description
11	Arrival	92S	Bow First	NW x 25 kts. + 10min 35kts gust	Ebb x 2.5 kts.	Emergency	Extreme NW winds & sustained gust near terminal + ebb tide arrival @ 88N - most common gusts from NW and highest tidal currents
12	Departure	92S	Stern First	NW x 25 kts. + 10min 35kts gust	Ebb x 2.5 kts.	Emergency	Extreme NW winds & sustained gust near terminal + ebb tide departure @ 88N - most common gusts from NW and highest tidal currents

The desktop navigation simulation matrix was intentionally designed to represent the upper limit of environmental conditions experienced at MCT, with wind and current values combined to create scenarios that, while physically possible, are very rare in practice. These simulations provide insight into the extreme bounds of safe navigation for the Design Vessel, allowing for assessment of vessel performance under rare but plausible stress conditions.

To provide context, Figure 7-2 shows wind and current conditions during cruise ship arrivals and departures in 2023 and 2024.<sup>22, 23</sup> These values were determined by cross-referencing the beginning of both arrival and departure maneuvers for cruise ships in the 2023 and 2024 AIS dataset with historical current and wind data during the same periods of arrival and departure. The data demonstrate that typical operations occur under substantially lower environmental forces than those modeled in the simulations. These historical observations should be taken into consideration when interpreting the run outputs, as the simulations are designed to test the vessel and terminal performance at a more conservative, worst-case limit rather than representing the conditions most frequently encountered.



**Figure 7-2: Observed Conditions During 2023 and 2024 Arrivals and Departures of Cruise Ships at MCT**

<sup>22</sup> National Weather Service, *National Weather Service Wind Speed and Direction Data for New York, NY (Station KNYC)*, retrieved October 9, 2025 (data for Jan. 1, 2023–Dec. 31, 2024).

<sup>23</sup> National Oceanic and Atmospheric Administration, *Hourly Current Predictions for Station NYH1928 (New York, NY), Bin 12 (6 Feet Depth)*, accessed October 9, 2025 (data for Jan. 1, 2023–Dec. 31, 2024).

Referencing the potential differentiation between an actual Icon Class cruise ship and the design vessel used in these simulations, it is noted that a 3% increase in wind speed represents a nearly 10% increase in windage area in terms of the wind force exerted on the vessel. As the environmental conditions simulated represent an upper range of wind speeds that are experienced on the water, there is a built-in safety margin in these simulations that accounts for any potential discrepancy in the windage area modeled in the DNS compared to the actual particulars of an Icon Class ship. Future analyses will further refine the vessel model used and the environmental conditions experienced by cruise ship operators.

#### 7.4 **Commentary on Bow First Versus Stern First Arrivals**

Under current operating practices at MCT, nearly all cruise ship arrivals are performed bow first. This aligns with long-standing local navigation protocols and the established preferences of pilots and tug operators familiar with the site. Discussions held with cruise ship docking pilots operating at MCT confirmed their strong preference for bow-first arrivals.

One of the main reasons stated for this preference relates to the location of the vessel's main propulsion system, which is situated at the stern. With the Proposed Project extending further into the Hudson River, vessels will need to navigate under the influence of crosscurrents and lateral winds over a longer final approach distance. Approaching bow first allows the vessel's primary propulsion to remain oriented with the environmental forces, enabling the crew to apply more corrective thrust to counter drift and maintain heading control more effectively.

This configuration can enhance overall situational control and maneuvering precision during the critical final approach phase.

The DHI Master Mariner overseeing the desktop navigation simulations similarly expressed a preference for bow first arrivals, citing the improved visibility and situational awareness offered to the bridge team. When approaching bow first, navigators have clear visual cues of the terminal structures, adjacent berths, and potentially adjacent moored vessels. In contrast, a stern-first approach substantially limits visibility toward the terminal, requiring heavier reliance on tug coordination and reduced visibility of visual aids.

Furthermore, stern-first approaches raise operational and environmental concerns related to propwash induced currents. When operating under challenging environmental conditions, higher propulsion power may be required to maintain control, resulting in strong propwash effects. These currents can increase seabed scour, mobilize debris (such as driftwood or ice) within the basin, and pose potential risks to both the vessel's propellers and terminal infrastructure. These strong induced currents can also pose problems related to mooring line forces for adjacent moored vessels.

Despite these considerations, there are scenarios where a stern-first approach may be preferred. For example, the following points were raised by a master mariner engaged by Hatch on this project:

- Berthing stern first allows the bow to continue restricting the axial tidal current, providing more and longer overall control. In this case, assuming an ebb current, which is typically

of a higher velocity and a longer duration than the flood, by berthing stern first, the bow initially stems the prevailing current flow and maintains the prevailing wind on the port quarter/port beam. This allows the pilot to swing the stern downwind, to starboard, toward the berth area, and out of the mainstream axial current, while negating downriver drift and maintaining positional control in the river. In setting up the alignment in this way, fine and accurate control of the stern can be achieved. Positioning the vessel in this way allows fine corrections of both the bow and stern as the vessel swings stern first into the berth. It should be noted that the bow, because of its fine lines, less windage, and less underwater resistance, will also follow the swing of the stern easier. In comparison, approaching bow-first into the berth, requires the stern (large windage area) to be swung to port, up-wind as, at the same time, the current is setting the hull down river, onto the berth (pier extension). This is a potentially dangerous alignment as the hull becomes increasingly perpendicular to the current.

- Berthing stern first, bow out allows an immediate, natural 'go-around' or 'bail-out' alignment throughout the maneuvering and berthing period.
- Berthing stern-first, bow out, provides a smaller and finer profile (of the bow) to wind and water. According to standard ship handling practices, this procedure not only provides for a 'bail-out' scenario but should, hydrodynamically, require the use of less engine and bow thruster power.
- Once alongside and secured, the bow, being finer with less under and above water area, is less susceptible to the mooring forces imposed by the changing tidal currents and eddies and, possibly, to the effects of passing marine traffic.
- Departure is enhanced by greater visibility up, down and across the river (Bridge first), spatial awareness and, ultimately, swing control (e.g., powerful Azipods to control the swing of the stern).
- By entering the berth bow first, the stern, on departure, swings further into the navigable channel and closer to the opposite edge of the river, while the bow gets very close to the end of the extended pier as it swings down river.
- Allowing for the increased power and maneuverability of the Design Vessel and a variety of river and environmental conditions, berthing bow first would potentially involve more work against the elements while potentially inheriting more risk and offering less margin of safety than berthing stern first.

Different captains may have varying preferences and interpretations of the same maneuver, even under similar environmental conditions, based on their individual experience, training, and comfort with vessel response. This naturally allows for differing opinions on whether a bow-first or stern-first approach is more suitable in a given situation. Ultimately, the best method depends on the prevailing conditions at the time, and maintaining both options expands the operational flexibility and overall berthing window, making the berths at MCT more versatile and attractive to the diversity of all cruise ship operators.

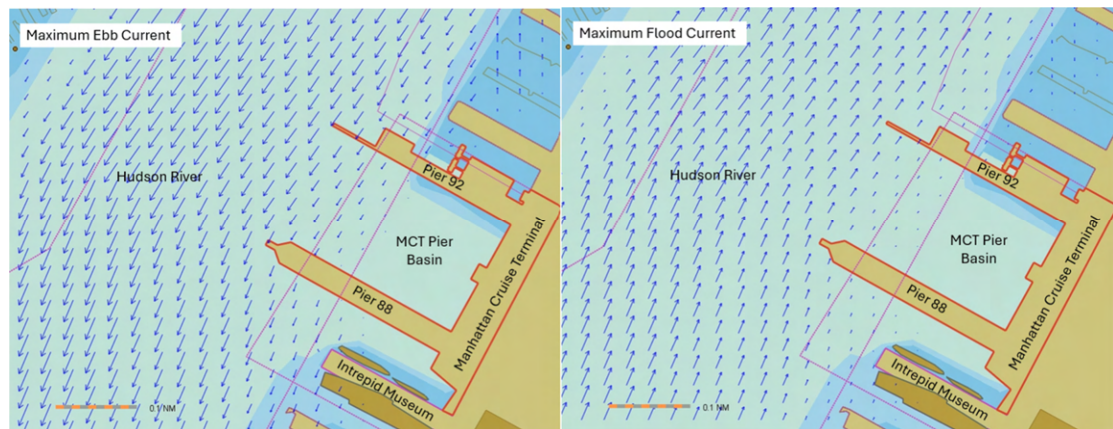
While the modeling in this study’s desktop navigation simulation only included one stern-first arrival, future studies may incorporate additional stern-first arrivals to fully understand the suitability of all approach types at the redeveloped MCT.

## 7.5 Key Assumptions in Desktop Navigation Simulations

The following assumptions were made for the simulation study:

- All simulations were conducted using the proposed redeveloped terminal layout with other adjacent berths already filled with moored vessels (e.g. simulations at 88N assumed both 88S and 92S already had vessels moored).
- There was no traffic situation impeding the ship during its berthing and un-berthing maneuvers.
- There was no other traffic movement during the ship transit along Hudson River channel.
- Bathymetry inside the proposed MCT berths was assumed to be similar to current dredge depths at MCT and were applied as a constant 11.9 meters (39 feet) below MLLW datum.

For the simulations, constant tidal currents were applied for each respective scenario. It is expected that the mooring dolphins proposed at MCT would provide some sheltering effect on currents, and currents would essentially reduce to zero inside the basin between 88N and 92S. In the absence of detailed hydrodynamic modelling (not part of this scope of work), an assumed interpolated 2D field of currents was applied in the simulation to represent these effects. These interpolated current fields are shown in Figure 7-3. The freestream currents were applied according to the run table, reducing to approximately 50% freestream speed between the proposed dolphins, and reducing to zero inside the main MCT basin.



**Figure 7-3: Assumed 2D Hydrodynamic Current Fields Applied in the Desktop Navigation Simulations**

During selected simulation runs, Vector Tugs were used to simulate a 60-ton bollard pull of an azimuth stern drive (ASD) tug of 30-meter (98-foot) length overall (LOA). This towing capacity is a conservative estimate as there are currently tugs in New York Harbor that are

rated to 85-ton bollard pull, and this increased capacity would likely improve the maneuvering capabilities for berthing and unberthing cruise ships. The vector tugs are controlled by the master mariner and can push or pull in a given direction. Length of tug line used was between 35 meters (115 feet) to 60 meters (197 feet) and changes depending on surrounding space available when pulling on ship. Just like real tugs, vector tugs are influenced by current, the assisted ship's speed, the wind force and require a realistic time span to move/change position.

Most importantly, in all simulation scenarios, the maximum power available to the cruise vessel's Azipod and bow thruster systems was intentionally capped to reflect realistic operational constraints. This approach ensures that the simulated vessel performance remains within the safe power limits routinely observed in actual navigation practice.

Captains and pilots typically refrain from operating main propulsion or thruster systems above certain thresholds to avoid excessive mechanical stress, maintain control stability, and ensure redundancy during critical maneuvers. Accordingly, the SimFlex simulations enforced these operational caps, limiting thruster output. This conservative configuration provides a more realistic representation of the Design Vessel's maneuvering performance and ensures that the resulting navigation feasibility assessments accurately reflect practical and safe vessel handling conditions. The assumptions were as follows:

- Only four of the five bow thrusters were available for use, and the combined power of these four available bow thrusters amounted to approximately 50% of all available bow thruster power on the Icon Class bow thruster systems (11,250 kW of installed 22,500 kW). Effectively, each of the four bow thrusters had 2,800 kW of available power in the DNS.
- Only two of the three Azipod main thrusters were available for use, and the combined power of the two available main thrusters amounted to approximately 67% of all the available main thruster power on the Icon Class main thruster systems (40,000 KW of installed 60,000 KW). Limiting the power available to the stern thrusters integrates a safety margin for maneuvering provided by the vessel's main propulsion.

## 7.6 Desktop Navigation Simulation Outputs

For each of the runs listed in the simulation matrix, a standard set of reporting was generated outlining the details of the arrival or departure. In addition to general commentary and the necessity and quantity of tugs required, this also includes a grading for the result of the simulation, and a grading for ship handling difficulty throughout the maneuver. These are outlined in Table 7-5 and Table 7-6.

Grading criteria are not necessarily consistently defined across the industry. Descriptions and results will vary across companies and across Master Mariners performing the simulations. The criteria below should only be used in conjunction with the results outlined in this report. Future analyses, such as full bridge mission simulations, will likely have different grading

descriptions to qualify results and will require involvement by cruise ship operators to refine success criteria, maneuvering specifications, and proximity characteristics.

**Table 7-5: Grading Description for the End Result of the Simulation**

Successful	To obtain the grading “successful” the simulation must be completed with a satisfactory safety margin. A satisfactory safety margin is defined as the situation where the tested port layout, channel transit and the environmental conditions provide sufficient under keel clearance to avoid grounding, sufficient distance to shallow water areas, exclusion zone, safety buffer zone and a possibility to correct minor maneuvering mistakes without compromising the safety.
Marginal	The grading “marginal” is given for the simulations which were completed successfully but needed full utilization of all available resources, hence no or little possibility of correction error or misjudgment.
Fail	The grading “fail” is given for simulations that could not be completed with the available resources. Example collision, aground etc.

**Table 7-6: Grading Description for Ship Handling Difficulty**

Comfortable	<p>Description: Ship handling is routine, with the vessel responding predictably and smoothly to commands. Maneuvering requires minimal input and corrections.</p> <p>Stress Level: Very Low. Feels relaxed and confident. There is no sense of urgency or pressure, allowing for a calm and controlled operation.</p> <p>Maneuver is suitable for all levels of ship handlers with basic handling skills.</p>
Easy	<p>Description: Ship handling is straightforward, with the vessel responding well to commands. Maneuvering requires some input but remains easy to control.</p> <p>Stress Level: Low. Feels at ease with minor attention required. Situations are manageable with occasional, simple corrections, leading to a generally calm experience.</p> <p>Maneuver is suitable for ship handlers with some experience in ship handling.</p>
Moderate	<p>Description: Ship handling requires consistent attention and skill. The vessel responds to commands but may need regular adjustments to maintain control.</p> <p>Stress Level: Moderate. Experiences a moderate level of stress. Regular attention and decision-making are required, leading to a state of alertness but not overwhelming pressure.</p> <p>Maneuver is suitable for ship handlers with intermediate handling skills.</p>
Difficult	<p>Description: Ship handling is challenging, requiring high levels of skill and experience. The vessel's response to commands requires precise adjustments, and maintaining control demands constant focus.</p> <p>Stress Level: High. Feels significant stress and pressure. High concentration and precise maneuvers are necessary, with little room for error, leading to a demanding and intense experience.</p> <p>Maneuver is suitable for advanced ship handlers.</p>
Challenging	<p>Description: Ship handling is extremely difficult, requiring expert-level skill and extensive experience. The vessel's response is unpredictable, requiring exceptional precision and continuous, fine-tuned adjustments to maintain control.</p>

	<p>Stress Level: Very High. Feels under extreme stress and pressure. Every action requires careful consideration and must remain highly focused and alert at all times, leading to a highly stressful and challenging experience.</p> <p>Maneuver is suitable for expert ship handlers only.</p>
--	--

A summary table containing the outputs of each of the desktop navigation simulations is shown in Table 7-7. Please note that the maximum applied power in this summary table includes the assumptions listed in Section 7.5. Additionally, the four available bow thrusters are presented as two groups of two. As such, in the simulation outputs, percentage of power output is relative to the capped limit of the bow thrusters and main thrusters, respectively.

For example, 100% of combined applied bow thruster power is equal to 50% of installed bow thruster power on the Design Vessel, and 100% combined main thruster power corresponds to 67% of installed main thruster power on the Design Vessel. At no point in any simulation did stern thruster power go above 67% of installed. And at no point in any simulation did bow thruster power go above 50% installed.

Please refer to Table 7-7 for more detailed outputs and descriptions of the runs.

**Table 7-7: Summary Table of Desktop Navigation Simulation Outputs**

Run No.	Status	Berth	Aspect	Wind Velocity	Current Velocity	Alongside	Max. Power % Pod 0*	Max. Power % Pod 1*	Max. Power % Bow Thruster Pair 0*	Max. Power % Bow Thruster Pair 1*	Tugs Used	Tug Max. Power %	Ship Handling Grading	Completion Grading	Duration (mins)
1	Arrival	88N	Bow First	NW x 25 kts.	Ebb x 2.5 kts.	Starboard	76	65	100	100	0	-	Moderate	Marginal	33
2	Departure	88N	Stern First	NW x 25 kts.	Ebb x 2.5 kts.	Starboard	85	85	90	92	0	-	Easy	Successful	21
3	Arrival	88N	Bow First	NW x 25 kts.	Flood x 2.0 kts.	Starboard	79	64	79	67	0	-	Moderate	Successful	18
4	Departure	88N	Stern First	NW x 25 kts.	Flood x 2.0 kts.	Starboard	67	80	50	51	0	-	Easy	Successful	20
5	Arrival	92S	Stern First	NW x 25 kts.	Ebb x 2.5 kts.	Starboard	86	85	84	88	0	-	Moderate	Successful	46
6	Arrival	92S	Bow First	NE x 15 kts.	Ebb x 2.5 kts.	Port	64	64	100	100	1	75	Moderate	Marginal	37
7	Arrival	92S	Bow First	NW x 25 kts.	Flood x 2.0 kts.	Port	80	67	55	60	0	-	Easy	Successful	28
8	Departure	92S	Stern First	NW x 25 kts.	Flood x 2.0 kts.	Port	73	73	79	80	0	-	Easy	Successful	18
9	Arrival	88N	Bow First	SW x 25 kts.	Flood x 2.0 kts.	Starboard	74	80	100	100	1	75	Moderate	Marginal	28
10	Departure	88N	Stern First	SW x 25 kts.	Flood x 2.0 kts.	Starboard	66	94	68	74	0	-	Easy	Successful	16
11	Arrival	92S	Bow First	NW x 25 kts. + 10min 35kts gust	Ebb x 2.5 kts.	Port	100	100	100	100	1	75	Difficult	Marginal	42
12	Departure	92S	Stern First	NW x 25 kts. + 10min 35kts gust	Ebb x 2.5 kts.	Port	100	100	100	100	0	-	Difficult	Marginal	15

\*Note that the percentage of applied thrust for both main pods and bow thrusters are reflective of the limited power capacities outlined in Section 7.5

## 7.7 Key Conclusions from Desktop Navigation Simulations

The conclusions and recommendations of the 2D desktop navigation simulation study apply only to the Design Vessel used under the tested environmental conditions and are drawn based on the results of the simulation exercise and the findings made by DHI's Master Mariner with due consideration to international standards and practices.

All conclusions were based on the assumption that future operations will be assisted or commanded by qualified pilots with experience in handling and maneuvering the ship. Equally it is assumed that the tugs, if used, are commanded by qualified and experienced tug masters.

The navigation simulation study runs were deliberately performed in "worst case" credible combinations of wind, and current conditions. This should be considered when reviewing these conclusions, as any reduction in environmental conditions would make maneuvering less intensive and potentially reduce any risks. In addition, limits were put in place on the available power for both bow thrusters and main propulsion; enabling the usage of unused bow thrusters or main propulsion would make maneuvering more feasible.

In summary, the simulation results and key conclusions of the 2D desktop navigation simulation study are as follows.

- The results of the desktop navigation simulation study concluded that it was feasible to approach, to berth, and to unberth the Design Vessel cruise ship at the new proposed extension layout at piers 88N and 92S.
- Once the ship enters the MCT pier basin, there was no significant concern with the berthing and unberthing the Design Vessel cruise ship at the proposed two piers.
- There was sufficient space inside the MCT Pier Basin for the Design Vessel cruise ship to maneuver to berth and unberth, even with adjacent moored vessels. There was enough clearance and distance for the possibility to correct minor maneuvering mistakes without compromising safety. There is only enough space for one design vessel to maneuver in the basin at a time.
- There was sufficient space in the Hudson River for the Design Vessel cruise ship to swing during berthing and unberthing.
- Out of the 12 simulation runs, 7 were completed with a completion grade of Successful completion and 5 with Marginal completion.
- Simulation run numbers 1, 6, 9, 11 and 12 were graded as "Marginal". The run was graded as "Marginal" because although the maneuver was completed successfully, maximum available bow thruster power and/or maximum Azipod stern thruster (with associated caps/limits, i.e. 50% of installed bow thruster power or 67% of installed stern thruster power) had to be used during the maneuver to bring the ship back in control, hence little possibility of correction error or misjudgment was reserved should something adverse happen.

- All simulation runs were carried out in maximum ebb (2.5 knots) and maximum flood (2.0 knots) tidal currents that flow across the mouth entrance of MCT Pier Basin.
- The combined force during strong northeasterly winds and maximum ebb current or strong southwesterly winds and maximum flood current requires the ship to have considerable power to control the bow of the ship during the ship swing into the MCT pier basin (see run numbers 6, 9 and 11).
- The wind speed of 25 knots and 35 knots used during the simulation study were on the high side and needed to be carefully managed.
- The maximum ebb current of 2.5 knots and flood current of 2.0 knots require careful management when planning a maneuvering strategy.
- The average approach speed of the cruise ship model was in the region of 4.0 kts, representing historical data of cruise ships maneuvering at MCT.
- It was demonstrated that the Design Vessel's two (of three available) main thrusters were able to provide adequate transverse and lateral force during the simulations.
- It was demonstrated that the Design Vessel's four (of five available) bow thrusters were able to provide adequate transverse force during the simulation runs except for runs 6, 9 and 11, where tug assist was necessary.

In general, departures from MCT are considered easier and safer compared to arrivals. This is largely because vessels begin the maneuver already aligned alongside the berth, reducing the need for extensive turning or lateral positioning at the start of the maneuver. This trend is also reflected in the desktop simulation run table, where departure scenarios generally show lower maximum thruster power usage, reduced tug assistance requirements, and shorter maneuver durations relative to corresponding arrival runs, highlighting the comparatively lower operational complexity and risk associated with vessel departures (when departing stern first).

## 8. Risk Identification and Assessment and Recommendations

### 8.1 Likelihood of Risks and Hazards

To establish a baseline understanding of navigational safety in the study area, an analysis of historical marine incident records was first conducted using data from the USCG Marine Information for Safety and Law Enforcement (MISLE) database. The MISLE database is a national repository that compiles information on reported marine casualties, pollution incidents, and law enforcement activities involving vessels and marine infrastructure in US waters. Each record contains details on the type of incident, vessel type, location, and date, allowing for the identification of trends and the estimation of historical accident frequencies.

By examining incidents occurring within and around the Study Area, this analysis provided a data-driven foundation for understanding existing levels of navigational risk and served as a benchmark for comparison with modelled results. In the SIREN assessment, passenger

vessels refer to ferries, tour boats, and smaller passenger transportation vessels, with cruise ships analyzed separately.

Building on this foundation, a quantitative navigational risk model, known as SIREN (Spatiotemporal Incident and Risk Evaluation for Navigation), was used to simulate both existing and proposed future vessel traffic scenarios in the Study Area. The model quantifies accident potential by representing vessel movements, behaviors, and interactions based on AIS-derived traffic patterns and physical navigation constraints.

This section of the report outlines the baseline risk levels found in the MISLE database, presents assumptions and limitations included in the SIREN modelling, as well as the output of the SIREN modelling quantifying risk trends and likelihood, and associated consequences.

It should be noted that over the past 25 years, the rate of marine incidents of all types both in New York Harbor and around the US has experienced a decline. This decline has been driven by several factors, including technological advances to increase safety of waterborne traffic and a societal expectation of greater professionalism and safety in the maritime industry. Increased regulatory scrutiny on maritime operators through USCG Subchapter M and enhanced port state control standards have reduced the frequency of substandard ships calling in the US. As a result, it is likely that the already low probability of risk outlined in the assessment below would continue to decline over time.

### **8.1.1 Historical Accident Frequency**

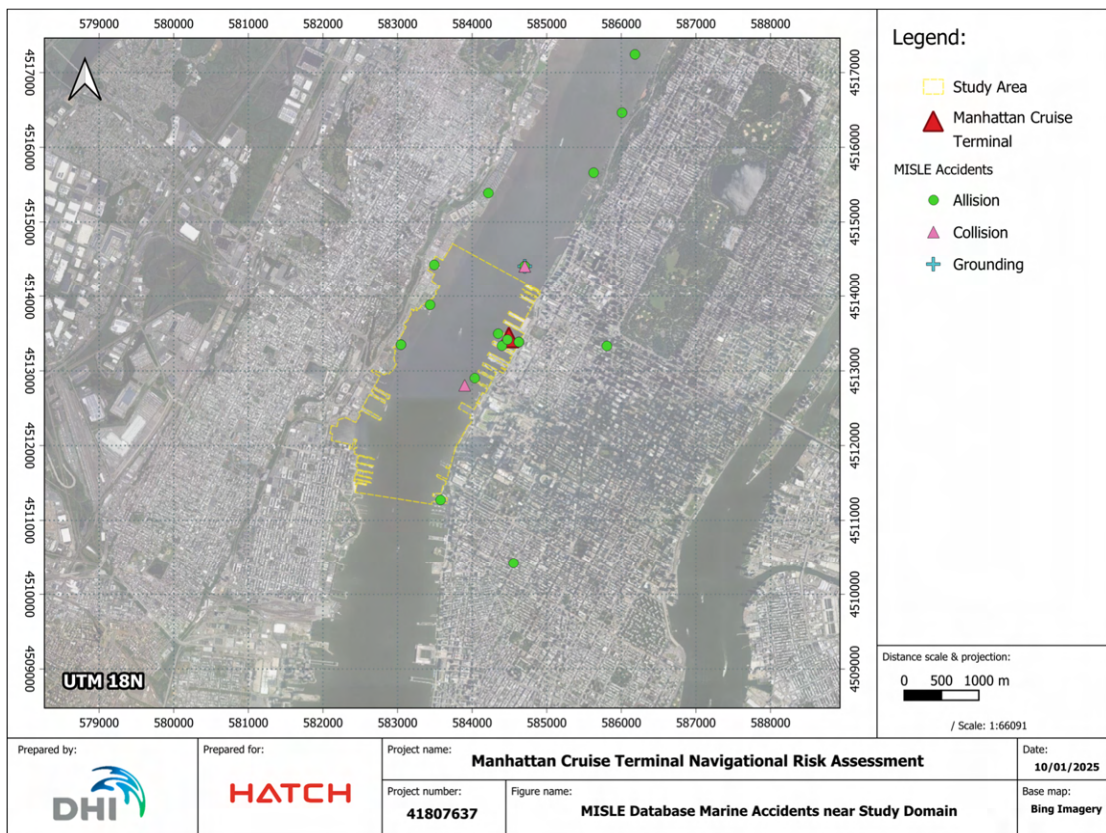
Historical accident data within the Study Area was extracted from the US Coast Guard's MISLE database for the 25-year period spanning 2000 through 2024. All reported marine incidents within the spatial extent of the Hudson River segment encompassing MCT and its adjacent approaches were compiled and spatially filtered to isolate relevant cases. A map of the extracted dataset is presented, illustrating the spatial distribution of recorded marine accidents across the Study Area.

From the full dataset, a subset of incidents corresponding to collisions, allisions, and groundings was identified, as these represent the primary accident types modelled within the SIREN quantitative navigational risk framework. This filtered dataset, summarized in Table 8-1, provided the empirical foundation for developing baseline accident frequencies and calibration of the SIREN model, allowing the SIREN model to be validated against observed historical conditions within the Study Area.

A map of these selected records from the MISLE database are shown in Figure 8-1. A total of 54 collisions, allisions, and groundings were identified in the MISLE database. Note that the geographic coordinates in some records are rounded or are of low precision, leading to some overlapping points as well as points that appear to be on land.

**Table 8-1: Historical Accident Rates from MISLE Database from 2000 through 2024<sup>24, 25</sup>**

Accident Type	Number	Annual Frequency (average accident per year)	Recurrence Interval (average years between accidents)
Collision	7	0.28	3.57
Allision	43	1.72	0.58
Grounding	4	0.16	6.25
Total	54	2.16	0.46



**Figure 8-1: MISLE Database Accidents Within the Study Area from 2000 to 2024**

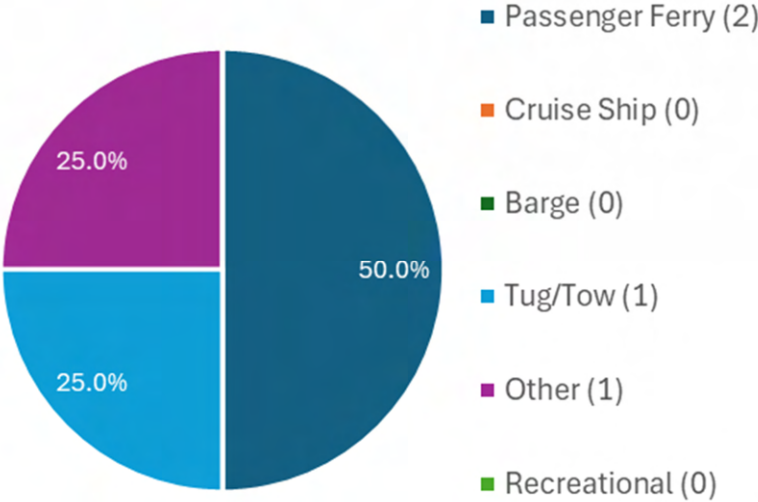
To further characterize the types of vessels involved in accidents, a series of pie charts were prepared illustrating the proportional breakdown of incidents by vessel class for each accident type. The analysis revealed that the majority of recorded accidents involved small passenger and ferry vessels, which also comprise the dominant proportion of overall vessel traffic in the

<sup>24</sup> U.S. Government, *Safety at Sea: U.S. Coast Guard Marine Casualty and Pollution Data for Researchers*, Data.gov, accessed December 1, 2025, <https://data.gov/maritime/safety-at-sea-us-coast-guard-marine-casualty-and-pollution-data-for-researchers/>.

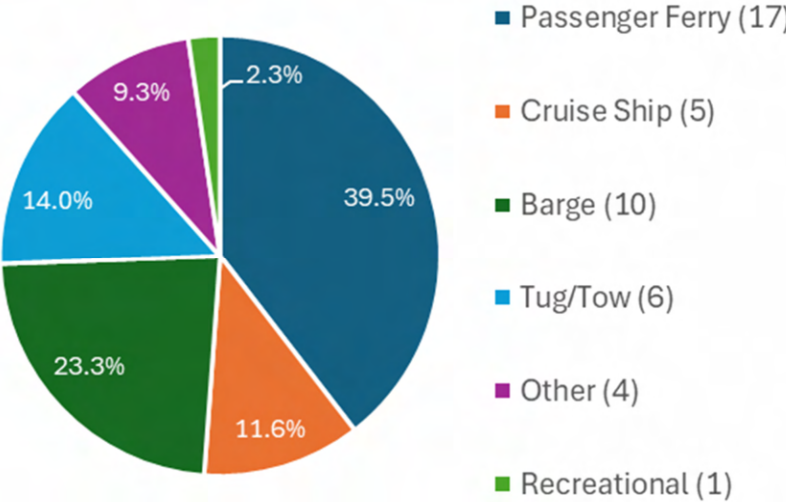
<sup>25</sup> Esri. *ArcGIS Online Map Viewer: Maritime Web Map*. Accessed December 1, 2025.

<https://www.arcgis.com/apps/mapviewer/index.html?webmap=1a7c38f1395240c99f0c729520641abb>.

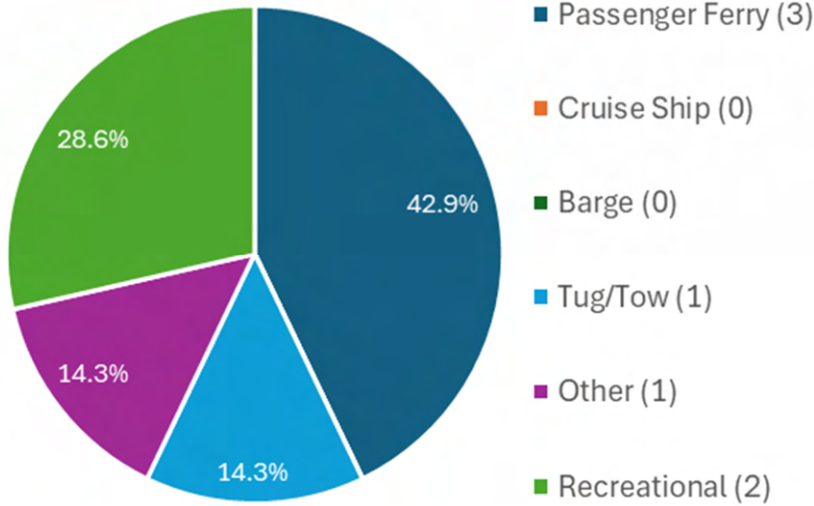
Study Area. These trends are depicted in Figure 8-2 through Figure 8-4, with statistics relative to the accident rates notes in Table 8-1.



**Figure 8-2: Breakdown of Groundings in the Study Area by Vessel Type**

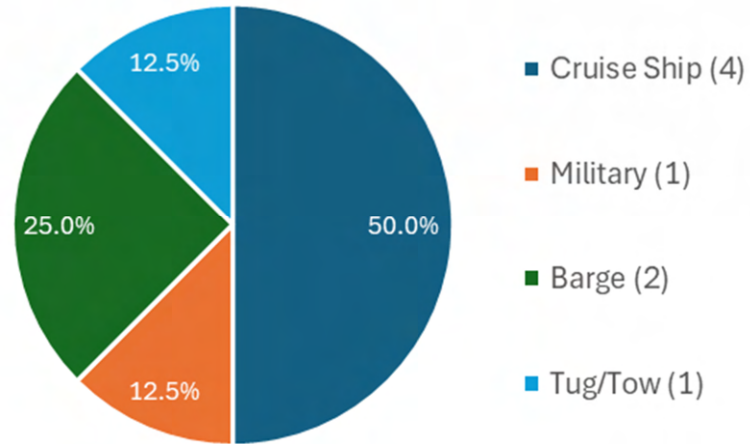


**Figure 8-3: Breakdown of Allisions in the Study Area by Vessel Type**



**Figure 8-4: Breakdown of Collisions in the Study Area by Vessel Type**

For allisions at MCT itself, a smaller subset of incidents was identified, amounting to a total number of 8 allisions over the 2000 through 2024 period. The breakdown of vessel types involved in these allisions are depicted in Figure 8-5. From the historical record, it appears the main source of allisions at MCT is in fact cruise ships as they are maneuvering in and out of the terminal. From the historical record of tug allisions, it is not possible to discern if the observed tug allisions represent vessels assisting cruise ships or other operations. Also, due to the limited precision in coordinates provided in the MISLE database, it is not possible to confidently discern which pier the historical allisions occurred at, or if they occurred at piers adjacent to MCT that are not related to operations at MCT piers. Nonetheless, these data provide an indication of the level of risk and vessel type trends at MCT.



**Figure 8-5: Breakdown by Vessel Type of Allisions at MCT Recorded in the MISLE Database Between 2000 and 2024**

**8.1.2 Quantitative Navigational Risk Modelling**

The quantitative risk assessment was conducted using DHI’s proprietary SIREN model. The SIREN model is a navigational risk modelling framework that is built on-top of DHI’s ABM Lab. This is a general-purpose agent-based modelling framework that has been customized and adapted to navigational risk. SIREN performs agent-based simulations to model vessel movements and behavior in realistic environmental and operational conditions.

SIREN is fully and seamlessly integrated with the broader MIKE Powered by DHI modelling suite, which allows for high-resolution hydrodynamic and environmental inputs to be incorporated directly into the vessel movement and risk modelling.

The SIREN modelling approach simulates each vessel as individual agents that are following data driven movement patterns and statistics derived from underlying AIS data. Users can also add traffic rules, alter historical patterns, generate synthetic data (e.g., future cruise ship traffic), and assess various “what-if” scenarios.

This system can also integrate high resolution, potentially dynamic, bathymetry for accurate grounding assessments and also incorporates both fixed and floating and/or drifting structures that may be influenced by environmental forcing (e.g., pier extensions).

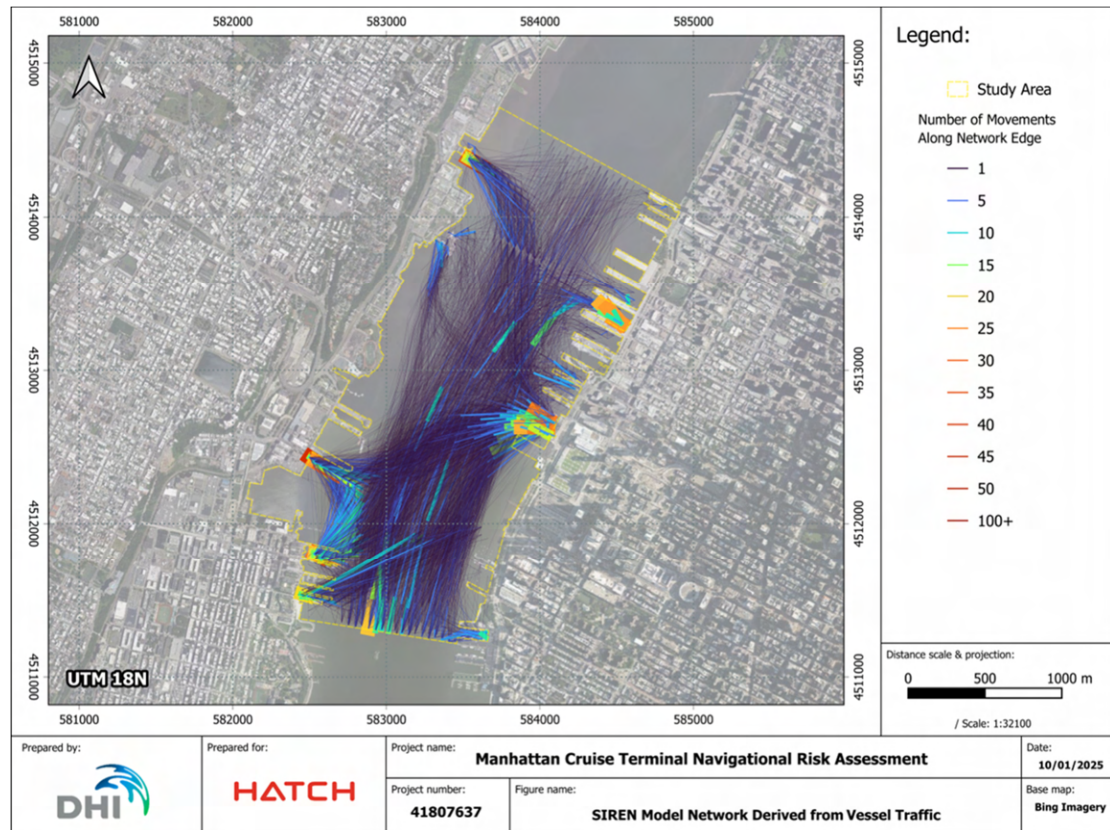
SIREN follows standard empirical risk calculation methodologies found in literature and has been benchmarked in idealized scenarios against literature and other common navigational risk modelling frameworks. However, the unique and inherent nature of the agent-based modelling approach leads to a detailed spatiotemporally varying risk assessment that can provide insight into risk patterns both spatially and over time that is not possible in other approaches.

Detailed information about location, timing, static and dynamic vessel characteristics of risk indices can be extracted from the model outputs providing detailed insight into navigational risk in the study area for mitigation measure development or planning purposes.

Furthermore, the unique unstructured graph approach (detailed below) allows for flexible, robust, and rapid model generation for both offshore areas and inland waterways, with traffic conditions ranging from random and sparse to well defined and regular. This ensures an accurate representation and assessment of all forms of vessel traffic that is not possible (or at least easily achieved) in other navigational risk modelling software, where sparse or temporally complex traffic is often omitted completely, or highly simplified for incorporation into risk estimates.

A more detailed explanation of the SIREN model, its capabilities, and methodology are presented in the Appendix K.

Following the methodology outlined in Appendix K, the following model network was developed as the basis of the SIREN quantitative navigational risk model, shown in Figure 8-6.



**Figure 8-6: SIREN Model Network Derived from Vessel Traffic**

#### 8.1.2.1 *Key Assumptions and Limitations in SIREN Modelling*

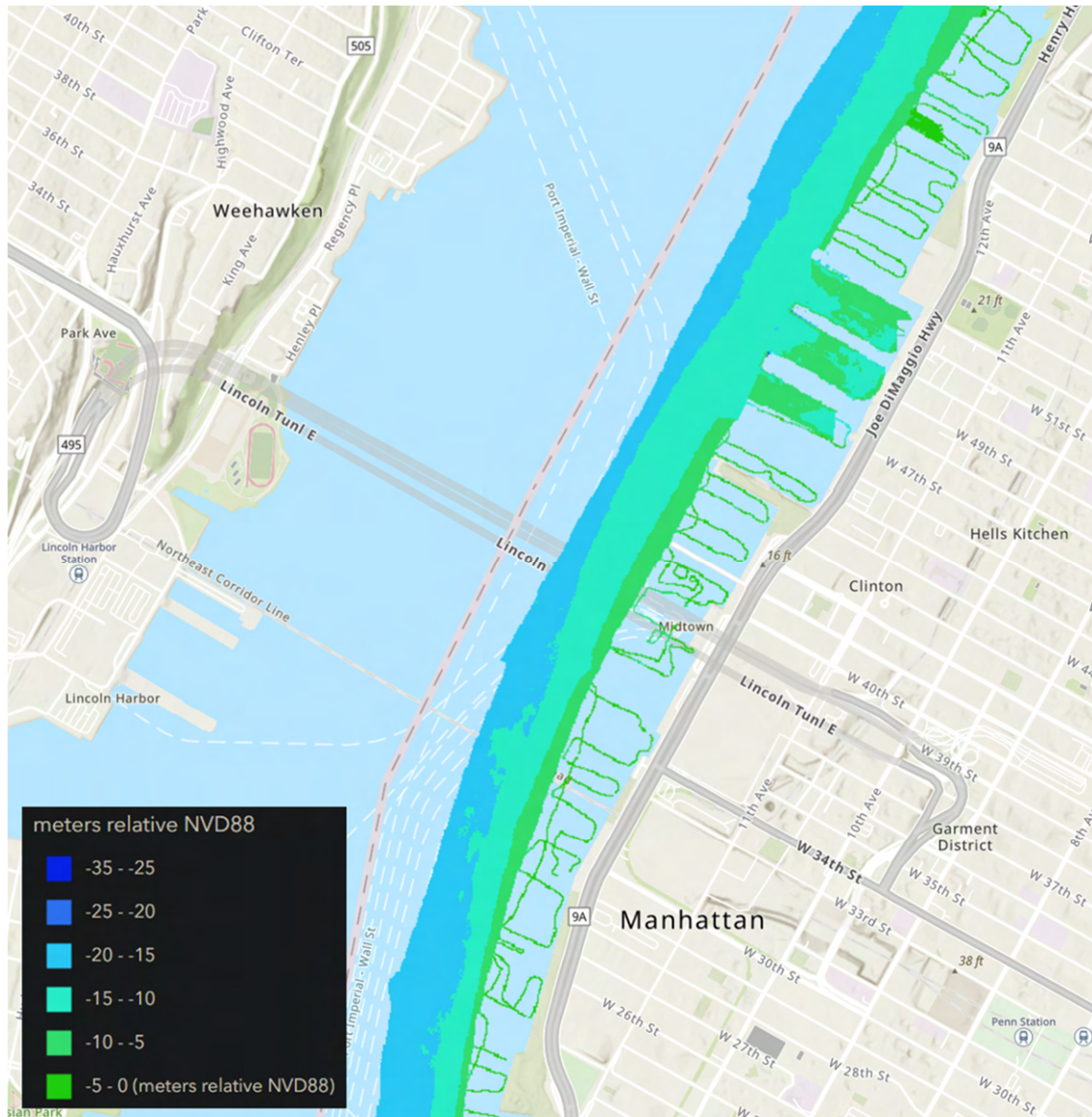
Several assumptions and limitations were considered in the modelling process. Areas along the nearshore shallow margins of the Hudson River on both the New York and New Jersey sides contained incomplete bathymetric coverage, which required supplemental data to create a continuous navigation surface for the simulations. Supplemental bathymetry data in these areas were taken from a 2015 NY Harbor survey (NYSDS (2024)) which is depicted in Figure 8-7.<sup>26</sup>

Two areas on the NJ side in particular, located at the Weehawken Ferry Terminal and the NY Waterway Ferry Yard, did not have readily accessible free bathymetry data to incorporate into the model. An educated estimate was applied to a flat bathymetry level in these locations representative of tidal levels and reported AIS drafts in the underlying data. It is, however, important to note that drafts reported in AIS may not always be accurate, and the nearest high-resolution tidal station to the Study Area is located at The Battery.

These assumptions and inherent data limitations mean that there is some uncertainty in the SIREN modelling results, particularly with regard to groundings, in these locations.

---

<sup>26</sup> New York State Department of State (NYSDS), *NY Harbor – Elevation of the Seafloor: e4sciences Survey 2015* [data set], accessed October 16, 2025, <https://www.arcgis.com/home/item.html?id=a972e361352a47e2b4d2f8de36751b42&utm>.



**Figure 8-7: Supplemental Bathymetry Data Taken from NY Harbor Survey**

Furthermore, while AIS data provides a robust representation of vessel movements, limitations in the free US Marine Cadastre AIS dataset (especially the lack of vessel-specific GPS antenna offset dimensions) introduces uncertainty in the precise positioning of vessel envelopes. This is especially relevant for larger vessels, and less impactful for smaller vessels (e.g., recreational or ferry vessels) where positional uncertainty could be in the order of approximately 5 to 10 meters (16.4 to 32.8 feet). For cruise ships operating at MCT, a programmatic correction was applied to accurately align vessel positions using known geometry and AIS metadata, improving fidelity for these key vessel classes and the largest vessels in the Study Area.

In addition, the following assumptions were also included in the SIREN modelling:

- As with the Desktop Navigation Simulations, bathymetry inside the proposed MCT berths was assumed to be similar to dredge depths currently present at MCT, and were applied as a constant 11.9 meters (39 feet) below MLLW datum.
- As with the Desktop Navigation Simulations, a representative interpolated surface was used to approximate the spatiotemporal variation of currents inside the MCT berth beyond the free stream current conditions reported in historical data, in absence of detailed hydrodynamic modelling.
- The speed and direction of both currents and winds followed patterns according to historical data.
- Traffic volumes in the future (beyond cruise ships) were assumed to be similar to existing conditions (e.g., there was no scaling of ferry vessels, recreational vessels, etc.).
- Where speeds and/or headings were either missing or determined to be anomalous, they were replaced with computed speeds (based on timing between known points) and coursing (based on direction between known points).
- Human powered boaters and other craft without AIS (e.g., kayakers or other recreational operations) were not included in the modelling due to the lack of data to quantify their volume, location, and frequency.

### 8.1.2.2 *Future Cruise Ship Scheduling*

Future cruise ship activity at MCT within the SIREN modelling framework was based on a projected range of potential future cruise call volumes under different development and demand scenarios. For the purposes of the navigational risk assessment, a higher-range projection of cruise ship calls in New York Harbor was selected as the most conservative estimate. Scaling for existing trends, this analysis estimated approximately 340 annual cruise ship calls at MCT in the future condition.

This represents a near doubling of existing cruise traffic, which historically averages around 170 calls per year based on 2023 and 2024 data. This projection provided an estimate for assessing the highest level of future cruise traffic conditions reasonably expected and associated navigational risks in the Hudson River adjacent to the terminal. For this, it was assumed that the monthly cruise ship calls volumes would be scaled according to existing trends.

To translate this annual and monthly forecast into a schedule for the SIREN model, a simplified temporal allocation was developed using the historical AIS-based cruise call records as a baseline. New vessel movements were inserted into days without existing arrivals, ensuring that the total number of daily arrivals never exceeded three cruise ship calls per day, consistent with operational and berthing constraints at MCT.

The future cruise fleet composition was distributed according to the projected mix from historical trends. In assigning berths, Icon Class-sized vessels were assumed to have priority at the newly constructed North and South Pier inner berths, while the Breakaway Plus Class-sized vessels were assigned preferential access to the berth located at the south end of the South Pier. When multiple berths were available, it was assumed that arriving cruise ships would preferentially occupy the inner berths first, optimizing maneuvering efficiency and available space for berthing.

For vessel classes not explicitly simulated in the desktop navigation studies, their arrival and departure maneuvering envelopes were assumed to resemble existing cruise ship movements, adjusted spatially to reflect the additional clearance required by the MCT expansion. For the Icon Class cruise sized ships, the specific maneuvering paths derived from the desktop navigation simulations were used directly, with all arrivals performed bow first and departures stern first, in line with operational preferences established through consultation with pilots and simulation results.

Finally, the timing of cruise ship arrivals on any given day were set to follow existing historical trends, with cruise ships arriving in the early morning (e.g., 6:00 am local time) and departing in the evening (e.g., 7:00 pm local time).

#### 8.1.2.3 *Routing of Background Traffic to Avoid Proposed Project*

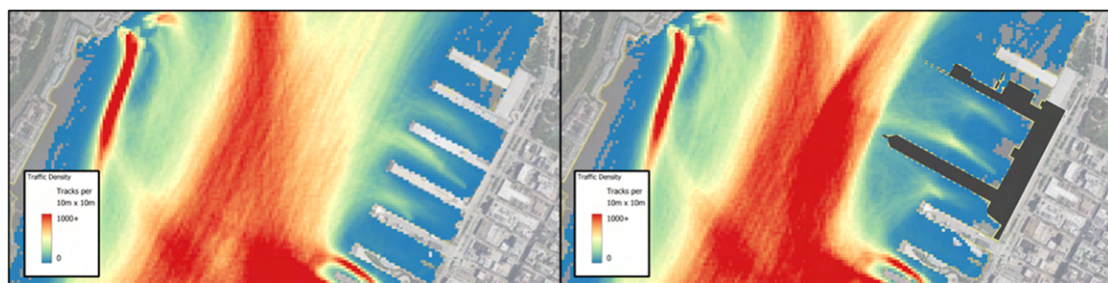
To account for the influence of the proposed MCT expansion on existing vessel traffic patterns in the Hudson River, an adjustment was applied to the background vessel routes in the SIREN model to ensure realistic spatial behavior in response to the new terminal footprint. Under the assumption that existing traffic patterns remained unchanged, a portion of vessel movements would now directly overlap with the future terminal piers (see Section 6.3.1). Of course, this would not happen in reality, as a portion of vessel traffic would essentially sail directly into the proposed terminal piers.

To address this, the model incorporated a route-shifting procedure for affected traffic segments. Specifically, for vessels whose existing tracks would intersect the extended pier structures, their paths were laterally offset further into the Hudson River, maintaining the same distribution of passing distance relative to the future terminal that they currently maintain with the existing piers. This ensured continuity in navigational behavior and realistic proximity relationships between through traffic and the expanded terminal.

For background traffic that did not overlap with the proposed pier extensions, the existing routes were left unchanged, preserving the natural variability and distribution of vessel movements throughout the remainder of the Study Area. This approach represents the minimal reasonable adjustment to existing traffic patterns: one that assumes vessels will continue to navigate as they presently do, only shifting when physical overlap would otherwise occur.

Importantly, this represents a conservative assumption in regard to allisions at MCT because background traffic continues to pass as close as historically observed, rather than assuming the establishment of a formal exclusion or buffer zone around the terminal. As a result, this approach produces a higher modeled exposure to potential allision risk than would likely occur in reality if operational traffic management or navigational exclusion areas were implemented and enforced, thereby providing a precautionary assessment framework within the SIREN modelling. Exclusion zones are discussed further in Section 5.8 as a potential mitigation measure.

A density map showing the existing and future conditions of background traffic in the Hudson River with these assumptions incorporated in shown in Figure 8-8.



**Figure 8-8: Density of Background Traffic in Hudson River under Existing and Assumed Future Conditions Near MCT**

#### 8.1.2.4 SIREN Model Outputs

##### 8.1.2.4.1 Overview of MISLE Data

As noted previously, the USCG MISLE database was used to baseline incidents in the study area. Table 8-1 provides a summary table presenting the number of collisions, allisions, and groundings recorded each year between 2000 and 2024 in the database, together with the corresponding accident frequencies and recurrence intervals.

This provides a concise overview of the historical accident record in the Study Area and forms the quantitative basis for comparison with the simulated accident rates generated through SIREN risk modelling.

##### 8.1.2.4.2 Overall Summary

To provide a high-level overview of navigational risk in the Study Area, two summary tables are presented: one for existing conditions and one for future conditions, showing the modeled accident frequency and recurrence interval for collisions, allisions, and groundings. These tables offer a concise comparison of risk across the Study Area and between operational scenarios, reflecting the combined influence of vessel traffic, terminal footprint, and environmental conditions.

**Table 8-2: Overall SIREN Model Results for Existing Conditions in the Study Area**

Type	Accident Frequency (average accidents per year)			Recurrence Interval (average number of years between accidents)		
	Powered	Drifting	Total	Powered	Drifting	Total
Collisions	0.19	0.03	0.22	5.15	33.78	4.47
Allisions	1.02	0.19	1.21	0.98	5.28	0.83
Groundings	0.22	0.05	0.27	4.45	21.23	3.68
Total	1.44	0.27	1.71	0.69	3.76	0.59

**Table 8-3: Overall SIREN Model Results for Proposed Future Conditions in the Study Area**

Type	Accident Frequency (average accidents per year)			Recurrence Interval (average number of years between accidents)		
	Powered	Drifting	Total	Powered	Drifting	Total
Collisions	0.22	0.03	0.25	4.71	30.12	4.07
Allisions	1.05	0.20	1.25	0.96	4.96	0.80
Groundings	0.22	0.05	0.27	4.49	21.51	3.72
Total	1.49	0.28	1.77	0.68	3.55	0.57

The existing condition results show a close correspondence with the historical MISLE database records, confirming that the model reasonably captures the spatial and temporal distribution of traffic and accident frequency while accounting for the assumptions and limitations discussed above.

It should be noted that drifting accidents represent a smaller proportion of overall risk; this is a function of the joint probability inherent in drifting events, which require not only the occurrence of an initial mechanical failure, but also the subsequent movement of the vessel under forcing from environmental conditions and resulting in an accident prior to vessel recovery (if recovery is achieved).

Comparing existing and future conditions, the SIREN outputs indicate that the largest changes in risk are associated with collisions and allisions, reflecting both the increase in overall traffic (particularly cruise ship movements), the change in background vessel traffic density in the Hudson River, and the addition of the MCT pier footprint. In contrast, grounding risk remains effectively unchanged across the Study Area, consistent with the unchanged bathymetric conditions across the Study Area, including within the MCT basin which has been assumed to maintain a similar level of dredge depths as currently exists according to the Spring 2025 post dredge survey.

In total, across the Study Area, the following takeaways can be extracted from this high-level summary.

- An overall increase of 0.07 accidents per year is expected, broken down into approximately 0.04 additional allisions per year (rounded to two decimal places), and 0.03 collisions per year (rounded to two decimal places).
- In terms of recurrence intervals, this translates into an average of 1 additional accident every 17 years (rounded to the nearest year), broken down into 1 additional allision every 25 years (rounded to the nearest year) and 1 additional collision every 33 years (rounded to the nearest year).

Overall, the modeled changes in navigational risk represent a relatively small increase to the total risk across the Study Area. This assessment assumes that background traffic follows the minimal impact offset assumptions outlined in Section 8.1.2.3, whereby vessels shift only as needed to maintain existing passing distances from the expanded MCT piers.

Even when considering that the largest vessels in the system (cruise ships) are effectively doubling in number (see Section 8.1.2.2), the infrequent nature of these movements means that the absolute contribution to total accident frequency remains modest.

Consequently, while the addition of the MCT expansion and future cruise ship operations does increase the likelihood of collisions and allisions interactions, the overall risk profile across the Hudson River remains largely consistent with existing conditions under these assumptions.

#### 8.1.2.4.3 Collision Risk in the Study Area

This sub-section presents an overview of collision risk specifically, broken down between vessel types for both existing and future conditions. This is shown in Table 8-4 and Table 8-5. These tables are color-coded to visually aid in understanding where risk is concentrated. Note that the color scale is not equal between the two tables and simply provides a visual indication of where risk is concentrated for that particular scenario.

Analysis of these results indicates that the vast majority of collision risk occurs between ferries interacting with other ferries, with a smaller contribution from ferries interacting with vessels in the Other vessel category. This pattern reflects the high frequency of ferry movements within the Study Area relative to other vessel types.

Collision risk probability heatmaps for the Study Area are presented in Figure 8-9 for both existing and proposed future conditions. As expected, the largest change in collision risk is concentrated directly adjacent to the Proposed project, where navigational space is most constricted and traffic density changes are highest.

A smaller increase is also observed along the approach and departure paths south of MCT, reflecting additional potential interactions between background traffic and the increased cruise ship activity. Among these, the greatest risk to vessel operations in the Study Area arises from ferry traffic, which dominates overall traffic in the system; the likelihood of a

collision involving a ferry is approximately one order of magnitude higher than with any other vessel type.

Overall, the increase in collision risk across the Study Area is relatively small, equating to:

- Approximately 1 additional collision every 33 years (rounded to the nearest year).
- For cruise ships specifically, the model estimates 1 additional collision involving a cruise ship approximately every 86 years.

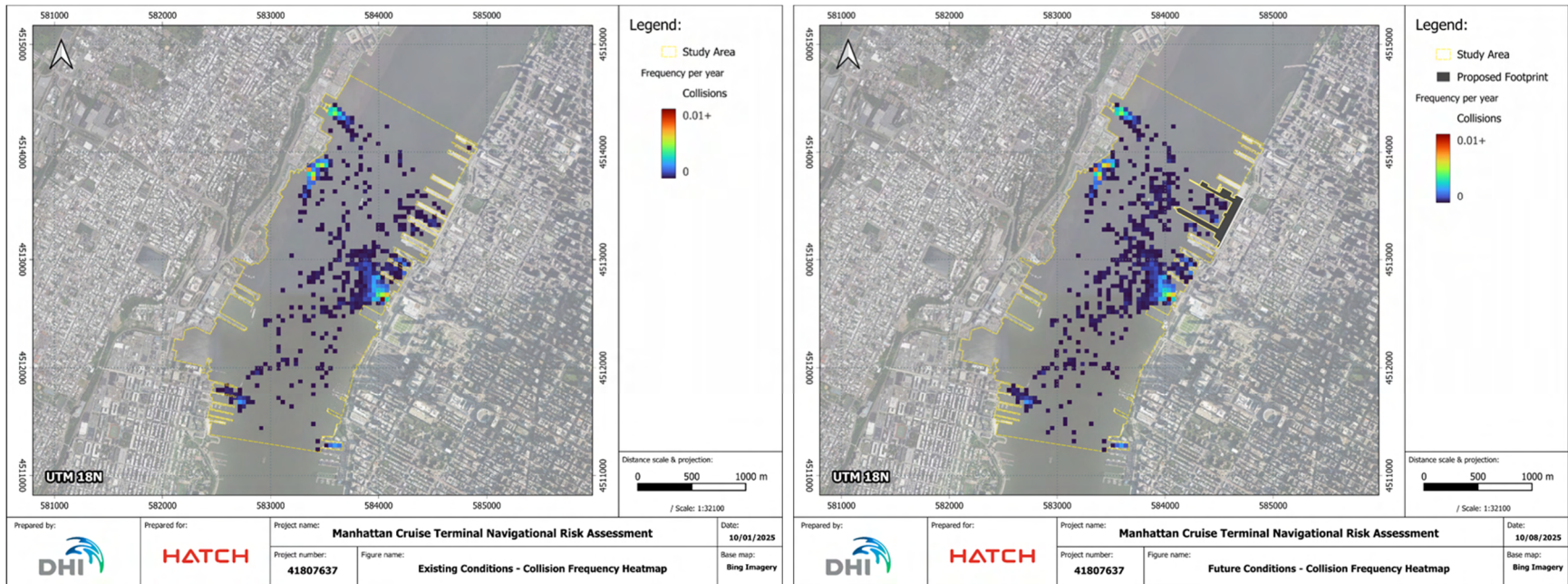
This highlights that the majority of the increase in collision risk is driven by adjustments in background traffic due to the Proposed Project rather than the cruise ship movements themselves.

**Table 8-4: Existing Collision Risk Frequency Broken Down by Vessel Type**

Existing Collision Frequency (average number of collisions per year)										
Type	Cargo	Cruise	Fishing	Military	Other	Passenger	Recreational	SAR	Tanker	Tug/Tow
Cargo	-	-	-	-	1.29E-04	1.29E-04	-	-	-	1.29E-04
Cruise	-	3.00E-04	-	-	2.00E-04	3.42E-03	-	-	-	8.00E-04
Fishing	-	-	-	-	-	-	-	-	-	-
Military	-	-	-	-	-	-	-	-	-	8.17E-04
Other	1.29E-04	2.00E-04	-	-	8.74E-04	1.36E-02	-	1.29E-04	-	1.27E-03
Passenger	1.29E-04	3.42E-03	-	-	1.36E-02	1.88E-01	8.23E-04	9.03E-04	1.34E-03	8.35E-03
Recreational	-	-	-	-	-	8.23E-04	-	-	-	-
SAR	-	-	-	-	1.29E-04	9.03E-04	-	-	-	1.29E-04
Tanker	-	-	-	-	-	1.34E-03	-	-	-	1.00E-04
Tug/Tow	1.29E-04	8.00E-04	-	8.17E-04	1.27E-03	8.35E-03	-	1.29E-04	1.00E-04	2.16E-03

**Table 8-5: Proposed Future Collision Risk Frequency Broken Down by Vessel Type**

Future Collision Frequency (average number of collisions per year)										
Type	Cargo	Cruise	Fishing	Military	Other	Passenger	Recreational	SAR	Tanker	Tug/Tow
Cargo	-	1.29E-04	-	-	1.29E-04	2.58E-04	-	-	-	1.29E-04
Cruise	1.29E-04	1.00E-04	-	-	5.16E-04	1.39E-02	4.90E-05	-	-	1.60E-03
Fishing	-	-	-	-	-	-	-	-	-	-
Military	-	-	-	-	-	-	-	-	-	7.55E-04
Other	1.29E-04	5.16E-04	-	-	1.00E-03	1.44E-02	-	1.29E-04	-	2.22E-03
Passenger	2.58E-04	1.39E-02	-	-	1.44E-02	1.92E-01	8.94E-04	1.00E-03	1.34E-03	1.09E-02
Recreational	-	4.90E-05	-	-	-	8.94E-04	-	-	-	1.00E-04
SAR	-	-	-	-	1.29E-04	1.00E-03	-	-	-	1.29E-04
Tanker	-	-	-	-	-	1.34E-03	-	-	-	-
Tug/Tow	1.29E-04	1.60E-03	-	7.55E-04	2.22E-03	1.09E-02	1.00E-04	1.29E-04	-	3.95E-03



**Figure 8-9: Existing (left) and Proposed Future (right) Collision Risk Frequency Density Maps in Study Area**

#### 8.1.2.4.4 Grounding Risk in the Study Area

The breakdown of grounding risk by vessel type for both existing and future conditions is summarized in and Table 8-7.

These tables are color-coded to visually aid in understanding where risk is concentrated. Note that the color scale is not equal between the two tables and simply provides a visual indication of where risk is concentrated for that particular scenario.

Analysis of these results shows that the majority of grounding risk is associated with small ferry vessels, which is consistent with the historical MISLE data discussed previously, and the overall trend of this type of vessel making up the majority of traffic in the Study Area.

For cruise ships, grounding risk is very low under existing conditions and is effectively reduced to zero in the future scenario due to the assumed planned dredge levels at MCT, which provide adequate under-keel clearance for even the Design Vessel across the full range of tidal levels observed at the terminal.

Overall, because the bathymetry across the Study Area remains largely unchanged (with only minor modifications at MCT) the total grounding risk between existing and future conditions remains effectively the same. This is apparent in Figure 8-10, which presents grounding risk frequency heatmaps for both existing and proposed future conditions.

Most traffic adjustments involve ferry vessels, which have small drafts and the changes in their routes primarily occur at deeper central portions of the Hudson River where grounding is not a concern.

Small changes in grounding risk observed for some vessel types are primarily a result of minor shifts in their routes, which slightly alter the tidal conditions at the time of arrival or departure from their respective piers.

Given the uncertainties in some of the shallow areas (as noted in Section 8.1.2.1, where grounding risk is concentrated), these variations represent a very minor overall change in grounding risk across the domain.

Overall, when rounded to the nearest year of recurrence interval between groundings compared to existing and proposed future conditions, there is no appreciable change in grounding risk.

**Table 8-6: Existing Grounding Risk Frequency Broken Down by Vessel Type**

Existing Grounding Frequency (average number of groundings per year)			
Type	Powered	Drifting	Total
Cargo	-	-	-
Cruise	1.59E-04	3.00E-04	4.59E-04
Fishing	-	-	-
Military	-	1.00E-04	1.00E-04
Other	2.07E-02	1.40E-03	2.21E-02
Passenger	1.89E-01	3.81E-02	2.27E-01
Recreational	1.59E-04	1.00E-04	2.59E-04
SAR	-	-	-
Tanker	9.86E-03	1.20E-03	1.11E-02
Tug/Tow	4.77E-03	5.90E-03	1.07E-02
Total	2.25E-01	4.71E-02	2.72E-01

**Table 8-7: Proposed Future Grounding Risk Frequency Broken Down by Vessel Type**

Future Grounding Frequency (average number of groundings per year)			
Type	Powered	Drifting	Total
Cargo	-	-	-
Cruise	-	-	-
Fishing	-	-	-
Military	-	1.00E-04	1.00E-04
Other	2.04E-02	2.50E-03	2.29E-02
Passenger	1.89E-01	3.87E-02	2.28E-01
Recreational	1.59E-04	-	1.59E-04

Future Grounding Frequency (average number of groundings per year)			
Type	Powered	Drifting	Total
SAR	-	-	-
Tanker	9.86E-03	1.50E-03	1.14E-02
Tug/Tow	3.02E-03	3.70E-03	6.72E-03
Total	2.23E-01	4.65E-02	2.69E-01

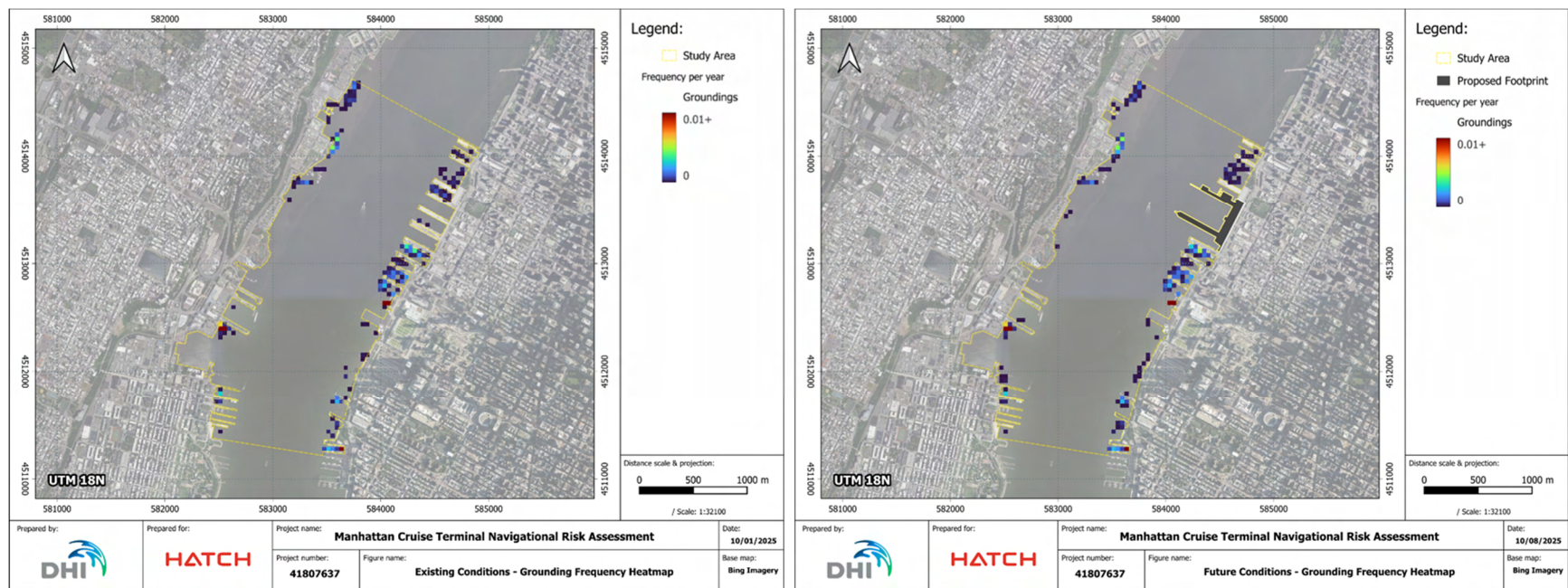


Figure 8-10: Existing (left) and Proposed Future (right) Grounding Frequency Density Maps in Study Area

#### 8.1.2.4.5 Allision Risk in the Study Area

The existing allision risk across the Study Area aligns closely with the historical MISLE data, reinforcing that the majority of allision risk is associated with ferry vessels, as expected, given their high traffic frequency and operations near various piers. This is shown in Table 8-8 and Table 8-9.

These tables are color-coded to visually aid in understanding where risk is concentrated. Note that the color scale is not equal between the two tables and simply provides a visual indication of where risk is concentrated for that particular scenario.

Because there are no major structures within the main channel of the Hudson River, allisions occur along the shoreline, reflecting potential vessel-to-structure allisions when vessels are arriving and departing from their respective piers and berths rather than interactions in open water. This is shown in Figure 8-11 which presents allision frequency heatmaps for both existing and proposed future conditions.

When comparing existing to future conditions, changes in allision risk are minimal. This is because most vessel routes remain unchanged near the shoreline of the Hudson River and near pier structures, and only a portion of traffic near MCT is shifted into the middle of the channel to accommodate the expanded terminal footprint. In addition, it was assumed that clearance between the proposed MCT footprint reflects a similar distribution of clearance to the existing terminal.

As a result, the only appreciable increases in risk are concentrated near MCT, and particularly for cruise ships, where powered allisions are the primary concern; these are addressed in more detail in the following section.

Overall, across the entire Study Area, the projected change in allision risk is small, representing:

- Approximately 1 additional allision every 25 years on average.
- Localized adjustments around MCT rather than widespread changes throughout the Hudson River and Study Area driving changes.

**Table 8-8: Existing Allision Risk Frequency Broken Down by Vessel Type**

Existing Allision Frequency (average number of groundings per year)			
Type	Powered	Drifting	Total
Cargo	-	-	-
Cruise	2.94E-02	1.32E-02	4.26E-02
Fishing	1.86E-04	1.00E-04	2.86E-04
Military	-	3.00E-04	3.00E-04
Other	3.20E-02	3.70E-03	3.57E-02
Passenger	9.38E-01	1.69E-01	1.11E+00
Recreational	2.98E-03	1.80E-03	4.78E-03
SAR	-	-	-
Tanker	9.30E-03	1.00E-04	9.40E-03
Tug/Tow	8.00E-03	1.50E-03	9.50E-03
Total	1.02E+00	1.89E-01	1.21E+00

**Table 8-9: Proposed Future Allision Risk Frequency Broken Down by Vessel Type**

Future Allision Frequency (average number of groundings per year)			
Type	Powered	Drifting	Total
Cargo	-	-	-
Cruise	5.52E-02	2.34E-02	7.86E-02
Fishing	1.86E-04	-	1.86E-04
Military	-	2.00E-04	2.00E-04
Other	3.12E-02	2.50E-03	3.37E-02
Passenger	9.38E-01	1.72E-01	1.11E+00
Recreational	2.98E-03	1.40E-03	4.38E-03
SAR	-	-	-

Future Allision Frequency (average number of groundings per year)			
Type	Powered	Drifting	Total
Tanker	8.18E-03	2.00E-04	8.38E-03
Tug/Tow	7.44E-03	1.70E-03	9.14E-03
Total	1.05E+00	2.02E-01	1.25E+00

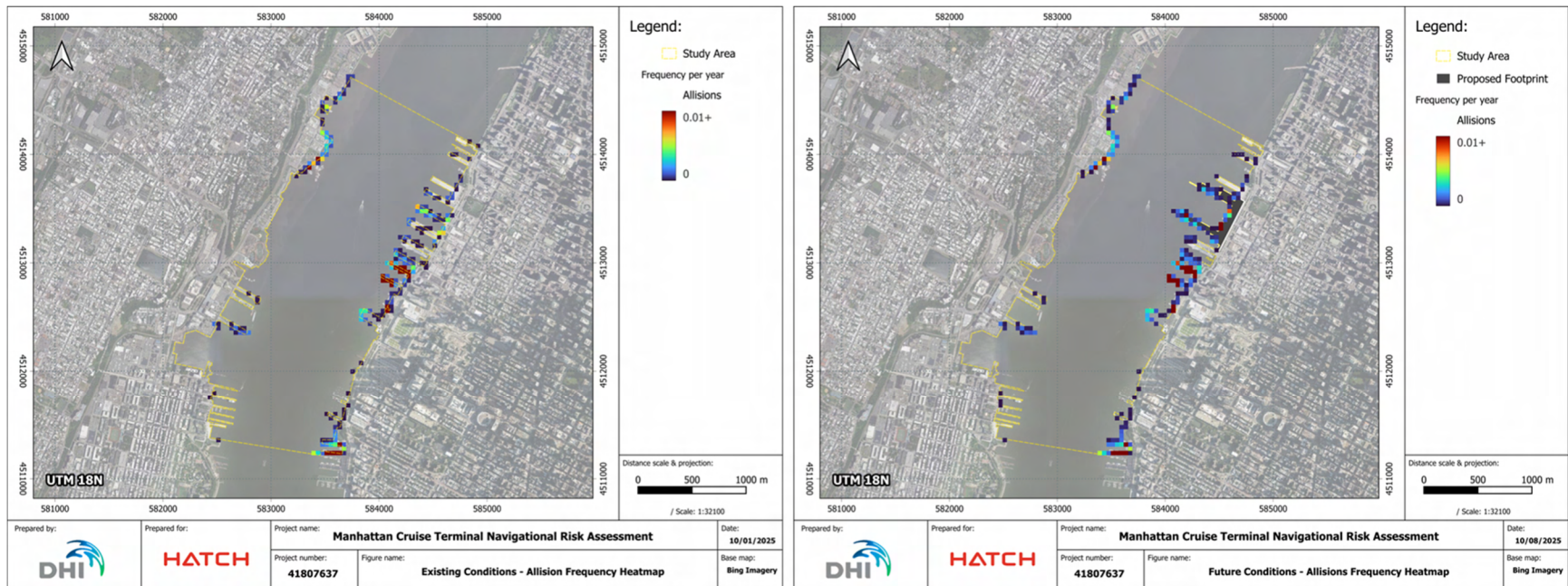


Figure 8-11: Existing (left) and Proposed Future (right) Allision Frequency Density Maps in Study Area

#### 8.1.2.4.6 Allision Risk at MCT

The allision risk analysis indicates that the majority of changes across the Study Area are concentrated at MCT, due primarily to the terminal expansion and the increase in cruise ship calls.

Under existing conditions, MCT accounts for approximately 5% of overall allision risk. Under the Proposed Project, this increases to roughly 8% of the total Study Area risk. Two tables (Table 8-10 and Table 8-11) break down allisions by vessel type for existing and future scenarios, showing that the majority of allision risk at MCT is associated with cruise ships. This generally aligns with the historical MISLE analysis and reflects the fact that the primary operational change at MCT in the future scenario is the increased frequency and size of cruise vessels.

In the future scenario, cruise ship calls are effectively doubled, with 18% of the increase from the largest vessels ever to call at the terminal (the Design Vessel), and 53% from Breakaway Plus class vessels, representing the mid-to-upper range of cruise ship sizes currently operating at MCT. This combination of increased traffic and larger vessels explains the intuitively expected modest increase in potential allisions at the terminal.

Two allision frequency heatmaps (Figure 8-12) illustrate these effects for both existing and proposed future conditions. In both existing and future conditions, a cluster of allision risk occurs at the inside face of the terminal, reflecting the close proximity of cruise ship bows to the inner portion of the terminal structures during mooring, and representing probabilities of slowly making contact with this part of the terminal structure. In the existing allision map, a clear concentration is seen at the south side of Pier 90, consistent with AIS data, indicating this as the most frequented berth, and historically corroborated by previous contact incidents.

The future allision map shows similar clusters, with some minimal additional risk located at the south side of the new piers, indicative of these same sorts of events. Additionally, there is a cluster of potential allision risk at the north side of the South Pier, where cruise ships are maneuvering in and out, and is concentrated beyond the line where the structure's dolphins would be located. This change reflects assumptions applied in the SIREN modeling; historic cruise ship maneuvers were adjusted to accommodate the terminal expansion but were not explicitly modeled in the desktop navigation simulations. Thus, there is some uncertainty in exactly where and what turning rate their maneuvers would begin and end (see Section 6.3.2).

For future phases of the project, performing detailed navigation simulations for a wider range of cruise ships would help refine standard operating procedures and potentially mitigate this risk. Overall, the analysis indicates that the majority of the allision risk increase in the Study Area is concentrated at MCT, with:

- An average increase of one additional allision every 25 years.

- The SIREN model estimating approximately 90% of this increase is attributable to cruise ship operations, with the remaining 10% is associated with other vessels such as tugs, bunkering operations, and a small proportion of passing background traffic.

**Table 8-10: Existing Allision Risk Frequency at MCT Broken Down by Vessel Type**

Existing Allision Frequency (average number of groundings per year)			
Type	Powered	Drifting	Total
Cargo	-	-	-
Cruise	2.88E-02	1.30E-02	4.18E-02
Fishing	-	-	-
Military	-	2.00E-04	2.00E-04
Other	1.12E-03	3.00E-04	1.42E-03
Passenger	1.12E-03	5.00E-04	1.62E-03
Recreational	-	-	-
SAR	-	-	-
Tanker	1.12E-03	-	1.12E-03
Tug/Tow	6.51E-03	8.00E-04	7.31E-03
Total	3.87E-02	1.48E-02	5.35E-02

**Table 8-11: Proposed Future Allision Risk Frequency at MCT Broken Down by Vessel Type**

Future Allision Frequency (average number of groundings per year)			
Type	Powered	Drifting	Total
Cargo	-	-	-
Cruise	5.51E-02	2.33E-02	7.84E-02
Fishing	-	-	-
Military	-	2.00E-04	2.00E-04
Other	5.58E-04	2.00E-04	7.58E-04
Passenger	1.86E-03	4.90E-03	6.76E-03
Recreational	-	-	-
SAR	-	-	-

Future Allision Frequency (average number of groundings per year)			
Type	Powered	Drifting	Total
Tanker	-	1.00E-04	1.00E-04
Tug/Tow	6.14E-03	1.10E-03	7.24E-03
Total	6.36E-02	2.98E-02	9.34E-02

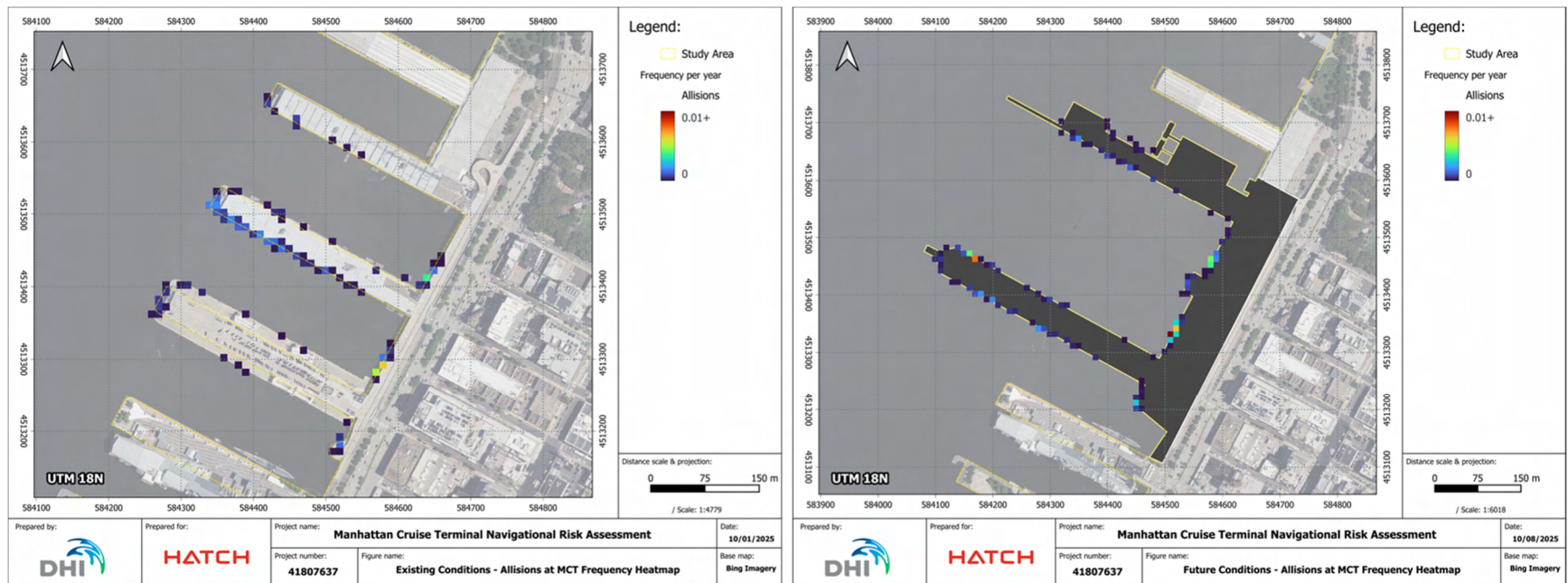


Figure 8-12: Existing (left) and Proposed Future (right) Allision Frequency Density Maps in at MCT

## 8.2 Future Considerations

### 8.2.1 *Hydrodynamic Modelling and Sedimentation*

While the current desktop navigation simulations provide valuable insight into the feasibility and safety of cruise ship operations at the Proposed Project, it is important to note that detailed hydrodynamic modeling was outside the scope of this study. Consequently, simplified assumptions were made regarding how the terminal extension and associated structures, including new dolphins and pier extensions, would influence the local river current patterns in the Hudson River.

These structural modifications will likely interact with the river's flow field in complex ways that cannot be accurately represented without dedicated hydrodynamic analysis, which was not in the scope of this NSRA. The extended piers and mooring dolphins will partially obstruct and redirect the main flow, potentially shifting the high-velocity core of the river further into the channel. This could lead to localized increases in current velocities in the channel. At the same time, the partial blockage effects of the dolphins may induce zones of recirculation and flow separation, altering how current speeds decay around the ends of the piers and within the berth basin, and changing where minimum velocities occur.

These hydrodynamic changes are critical to more accurately understanding the operating environment for large cruise ships during approach, berthing, and departure. At a future stage in the analysis of the MCT redevelopment, a more detailed 2D or 3D numerical flow model would allow these effects to be quantified and visualized, providing realistic current inputs for any future full-mission bridge simulation exercises.

Such modeling would not only refine the accuracy of vessel maneuvering assessments but also help identify potential areas of concern, such as zones of accelerated flow, altered sediment transport patterns, or areas where thruster-induced scour could be exacerbated. This modeling would also help refine long-term maintenance dredging requirements and assess whether changes in local hydrodynamics due to the terminal expansion could influence sediment deposition or erosion patterns, particularly around ferry routes and maneuvering areas. This would provide a more robust basis for the environmental conditions used in navigation simulations to better refine standard and emergency operating procedures of cruise ships (and other vessels) going to MCT.

Undertaking this level of hydrodynamic modeling in future project phases would therefore be a valuable next step to ensure that navigational simulations reflect the true hydrodynamic environment, thereby supporting robust and reliable design and operational decision-making for the expanded terminal.

### 8.2.2 *Adjacent Vessels and Mooring Requirements*

It is recommended to further evaluate mooring configurations and interaction forces between adjacent vessels berthed at MCT, especially given the larger cruise ships with tremendous propulsion power expected to berth in the future. This analysis should consider environmental loading, passing and nearby berthing/unberthing vessel effects, and the adequacy of existing

fender systems and mooring bollard arrangements. Updated mooring simulations or physical modeling could also help optimize berth utilization and improve safety margins during berthing and unberthing operations.

### **8.2.3 *Planned Construction Works and Ferry Traffic***

In Weehawken, New Jersey, across the Hudson River from MCT, NY Waterway is considering a redevelopment of their ferry operational and maintenance yard. This proposed redevelopment reportedly includes removal of the barges and finger pier that current occupy the area as their main yard space, installation of a new pile-supported pier, and renewing the breakwater that currently extends south approximately 305 meters (1,000 feet). The redeveloped pier layout will reportedly extend an additional 30.5 meters (100 feet) into the navigable waterway, pushing the pier extent and the breakwater to the edge of the Federally Authorized Channel from the New Jersey side.

Due to the channel constriction resulting from the Proposed Project, the redevelopment of the NY Waterway yard may further impact vessel traffic in this section of the Hudson River. It is recommended that future assessments examine how narrowing the navigable waterway from both the east and west affects vessel operations in the area.

### **8.2.4 *Operational Procedure Review***

As a future recommendation, it would be beneficial to expand navigation simulations to a broader range of cruise vessels operating at MCT. This would refine the spatiotemporal patterns of arrival and departure maneuvers, ensuring that both risk modeling and terminal planning accurately reflect the diversity of vessel operations and potential impacts of the proposed terminal footprint.

Given the projected increase in large cruise ship calls, Standard Operating Procedures (SOPs) and Emergency Operating Procedures (EOPs) for pilotage, tug assistance, and berth approach paths should also be reviewed and updated based on data provided from desktop navigation simulations. Future navigation simulations for a wider range of cruise ship classes would support the refinement of these procedures and identify potential mitigations for localized increases in allision or maneuvering risk.

### **8.2.5 *Environmental and Climate Resilience***

Future assessments should also consider climate change and sea-level rise impacts on navigational safety, under-keel clearance, and terminal operability. Coupling hydrodynamic models with projected sea-level and storm surge scenarios would provide valuable insight into long-term resilience planning.

## **8.2.6 *Integration with AIS and Real-Time Monitoring***

Finally, implementing or expanding real-time AIS-based monitoring systems near MCT could improve situational awareness and early warning capabilities for abnormal vessel behavior or near-miss events. Data collected from such systems could support continuous risk calibration and model validation for future operational safety management and provide a real-time glimpse at operations to understand the statistics and metrics easily of what is going to and from MCT.

# Appendix A: Project Risk Register

**Table A-1: Overall Project Risk Register**

<b>Risk ID</b>	<b>Originator</b>	<b>Risk Description</b>	<b>Risk Mitigation</b>
1	Sandy Hook Pilots Metro Pilots	Coming out into the channel at strength of current can be difficult when maneuvering cruise ship	Real-time current sensor at end of pier or on a buoy at the end of the dolphin. Optimization of vessel schedules within reason to reduce interaction with strong currents during departure.
2	Habor Pilots of NYNJ	With the piers located farther out, there's a concern that towing vessels may continue operating as they currently do—providing only brief assistance—rather than remaining made fast for longer durations. This could pose challenges for maneuvering vessels that require sustained towing support while approaching the berths.	Tug support upon approach. Optimization of vessel schedules within reason to reduce interaction with strong currents during maneuvers.
3	Vane Brothers	Losing pivot point on Pier 90 if demolished, particularly with larger vessels and larger stems, may increase the potential to run out of room between cruise ships during maneuvering.	Schedule barge movements carefully. Maintain safe separation buffers. Utilize the increased basin space once constructed.
4	Metro Pilots	How will the current change as a result of the infrastructure change?	Assessment of hydrodynamics of the proposed piers and their affect on the channel currents in future studies. Detailed hydrodynamic modelling and sedimentation in future studies.
5	Vane Brothers	Current will continue to run through mooring dolphins and may cause unpredictable eddies and currents.	Assessment of hydrodynamics of the proposed piers and their affect on the waters within MCT.
6	Metro Pilots	Increased prop wash may affect construction, shoaling, and scouring, particularly with those ships that moor at MCT for a long period of time.	Propwash induced current and scour assessment in future studies.
7	Donjon	Scows are around 135' and there should be enough space at MCT, but coming out into the current could be difficult to maneuver.	Potential need for larger tugs to combat current speed.
8	Moran	There is a risk of a support vessel (tug) losing power and being more exposed to vessel traffic and environmental factors since it is further into the Hudson. There is a risk that the vessels are more susceptible to emergency scenarios as they will be in the middle of the channel rather than tucked away closer to MCT.	Use larger or more tugs. Schedule movements during lower current periods, as possible.
9	Metro Pilots Vane Moran	Usage of Hudson River area around MCT by recreational users. As the plan for the piers is to extend further into the channel, the recreational users will be more exposed to faster currents and potentially more unsafe conditions	Standby emergency response vessel during arrival and departure of cruise vessels. Safety vessel or standby vessel to collect people and recreational vessels in emergency scenarios. Dredge operations has a crew boat at all

Risk ID	Originator	Risk Description	Risk Mitigation
			times for safety. Increased signage, awareness, and best practice instructions for recreational users at their origin and destination piers/docks.
10	Habor Pilots of NYNJ	Contending with current for vessels responding to emergency scenarios.	increase on site emergency response capabilities with redeveloped terminal plan.
11	Metro Pilots Sandy Hook Pilots Vane	Vessels may use South Pier dolphins as a pivot point during future operations. There is a risk that if the pier is not designed for this type of operation. As a result, the vessels could be damaged or cause damage to the infrastructure.	Take into account pivoting forces on South Pier dolphin for vessel entering into southern berth and apply appropriate fendering.
12	Vane Brothers	Pier 90 is currently used as a bail out point during maneuvering of barges and removal of this pier may cause risk of contact incidents where there isn't a point for barge's to maneuver off of.	Additional tugs may be required for maneuvering barges into position at redesigned MCT.
13	Metro Pilots	There is the potential that the piers are being overbuilt and over-extended into the channel, as there is sufficient mooring to accommodate the cruise ships currently.	Cruise ships need the additional pier infrastructure for landside support and access to aft hatches, particularly for the larger vessels. Also, cruise ships currently have issues with mooring line leads.
14	Habor Pilots of NYNJ	Challenges with the extreme beams of ships overhanging onto the terminal areas and further constrict the space for support vessels to maneuver.	The majority of cruise ships expected in the future are already frequenting MCT, and there will be more space inside the main basin once the expansion is completed. Vessel-specific approach planning and increased tug support may be needed for largest vessels.
15	MAPONY	The Hudson River is shallower on the NJ side, so extending the piers further into the Hudson will force cruise ship and other vessel traffic towards the NJ side and may increase potential risk of groundings.	The spatial extent of vessel route offsets are not expected to drive deep draft vessels beyond a limit where there is sufficient under keel clearance in the main channel, or appreciably change route patterns in shallow areas on the New Jersey side. Updated bathymetry survey and/or monitoring and increased pilot awareness through NTMs.
16	New York Fire Department	Increased scheduled ferry traffic over time may cause issues for emergency response vessels accessing the terminal in an emergency.	Increased coordination between ferry schedules and emergency operations.
17	New York Parks New York Police Department	Commercial vessel traffic interaction with human-powered vessel traffic has the increased risk of casualties and collisions.	Stakeholder outreach; dedicated kayak zones; warnings during commercial and cruise ship arrivals, additional communication measures between kayakers and commercial vessel users through marine radios.
18	New York Parks	With the present pier configurations, upstream piers are able to break ice flows. There is an	Increased ice monitoring; schedule movements to avoid ice flows; timely ice-breaking measures.

Risk ID	Originator	Risk Description	Risk Mitigation
		increased risk of vessels colliding with bergs with the new pier configuration that extends further into the channel.	
19	NYC Department of Environmental Protection New York Police Department Fire Department of New York	Increased number of construction vessels at the terminal during construction activities will increase risk of collisions, allisions, and groundings	VTS will need to provide updates regarding vessel traffic, surveys, diving at the terminals, with potential to designate specific person to control area. USCG will have to provide Local Notices to Mariners. NYPD also suggested creating "frozen zones" while the project is ongoing.
20	New York Police Department	In the summer months particularly, jet ski traffic increases considerably.	Stakeholder outreach with jet ski clubs and businesses, as well as Jersey Marine Task Force, to discuss mitigation measures.
21	NYC Department of Environmental Protection	Extending the piers into the channel poses an increased risk for allisions.	Lighting at the ends of the piers, additional aids to navigation, signage on dolphins, warnings to keep public out.
22	Fire Department of New York	With longer piers, there is an increased risk of allision at the terminal.	Enforcement of an exclusion zone around the extended piers to have background traffic avoid it at a specified offset distance.
23	Fire Department of New York	FDNY needs access to water supply during construction phasing and after construction is completed during emergencies.	Ensure that there are locations for the "Three Forty Three" to tie up, and a dry pipe standpipe system at the piers with manifold will allow FDNY to supply piers with water.
24	Fire Department of New York	If there is an emergency on the vessel or at the terminal, there is an increased risk associated with evacuating people.	Emergency response plans/drills, designated evacuation routes, dedicated safety vessels standby.
25	NYC Department of Environmental Protection	Without increased vessel security waterside, there likely will be an increased risk of incidents and breaches.	Security zone enforcement, with potential engagement of port authority police department.
26	NY Waterway	Future pier and breakwater at Weehawken Yard to extend 100/200 feet off of the New Jersey pier headline, which may further encroach on the navigable channel and impact vessel traffic.	Future analyses related to the Proposed Project should include how the NY Waterway yard redevelopment will also affect vessel operations on the Hudson.
27	NY Waterway	Currently, NY Waterway doesn't receive arrival or departure schedules, which causes increased risk of collision since they can't plan efficiently.	Suggested that VTS provide supplemental broadcasts with notices of arrival and departure of cruise ships.
28	NY Waterway	Risk to visibility that may increase casualties.	VTS currently provides adequate updates.
29	NY Waterway	Impact of construction phasing on vessel traffic may increase risk of allisions or collisions.	NY Waterway suggested VTS to implement slow bell in area, and they also suggested that the USCG could implement public outreach through their inspectors to inspected vessels regarding input to the NSRA.
30	NY Outrigger	The potential for extended piers and increased boundary of the USCG security zone will likely	Establishing a human-powered boating corridor that is physically marked by buoys or signage

Risk ID	Originator	Risk Description	Risk Mitigation
		cause paddlers to have to stay closer to the center of the channel and away from the more protected waters of shore, which increases the risk of incidents involving human powered boaters.	outside of the main navigation channel and outside of the USCG MSZ.
31	NY Outrigger	Fast moving boats who don't communicate adequately via VHF can increase the risk of incidents.	Streamline communication via VHF radio between all vessel operators.
32	HOPS Education Subcommittee	A lack of lighting on the dolphins increases the risks of casualties.	Installation of lighting on dolphins for redeveloped pier structure to ensure that casualties are kept at a minimum.
33	NY Outrigger	The mooring dolphins extending into the faster currents towards the center of the channel have the potential to create a hydrodynamic straining affect that can potentially cause harm to human powered boaters transiting in the area.	It is recommended that a hydrodynamic analysis of the mooring dolphins and pier infrastructure be conducted in the future to understand the effect these structures will have on the water moving past MCT. Future design of these structures should consider the hydrodynamic analysis to ensure that unpredictable currents and straining affects are reduced.
34	Manhattan Kayak	Piers 76 to 99 forms a uniform shoreline that allows cruise ships, tugs, barges, ferries, dinner boats, yachts, speedboats, jet skis, sailboats, and paddlers to travel in roughly parallel paths up and down the river. Smaller, slower traffic—such as paddlers—most often keep outside the main navigation channel, and therefore out of the way of larger boats. Extending some pierheads would break that alignment and force all vessels to shift course around new obstructions, creating choke points, increasing concentration of vessel traffic around the terminal, and increasing collision risk.	Establishing a human-powered boating corridor that is physically marked by buoys or signage outside of the main navigation channel and outside of the USCG MSZ.
35	Manhattan Kayak	Longer piers would block sightlines, especially after dark or during sunset glare. Paddlers use white lights, but other vessels may not see them in time. Many vessels are not monitoring VHF, and even when they are, large steel cruise ships can block line-of-sight radio signals between boats on opposite sides. A past ferry/kayak collision off Pier 76 showed how sun glare and missed radio communication can combine to cause serious accidents.	Using a red/green hold up/proceed flag system could be deployed and possibly echoed with a similar flag or light system atop the outermost dolphins.
36	Manhattan Kayak and Village Community Boathouse	New structures extending far into the river would alter the tidal flow, forcing currents to accelerate around them and creating suction	It is suggested that a hydrodynamic analysis of the pier extensions with a cruise ship at berth be conducted in the future.

Risk ID	Originator	Risk Description	Risk Mitigation
		zones. This, combined with turbulent eddies, can capsize, trap, or crush paddlers against structures.	
37	Manhattan Kayak	Cruise-ship support tugs often maneuver without open radio calls, backing and pivoting near the pierheads to dock, undock, and position barges. Extending the piers would leave paddlers less room to stay clear of these operations, forcing them closer to the main navigation channel, where conditions are rougher due to vessel traffic, wakes, and wind.	It is recommended that a hydrodynamic analysis of the mooring dolphins and pier infrastructure be conducted in the future to understand the effect these structures will have on the water moving past MCT. Future design of these structures should consider the hydrodynamic analysis to ensure that unpredictable currents and straining affects are reduced.
38	Village Community Boathouse	The risk of a new construction that extend out into the channel is the need to venture significantly further out towards the middle of the river to pass by. That puts them closer to those larger vessels, exposes them to more wind and current, and leaves them farther from potential egress points.	Deploying a safety boat or water traffic controller specifically looking out for the interests of recreational boaters would reduce risks, particularly during cruise ship arrivals or departures.
39	Village Community Boathouse	The terminal is located at a bend in the river, and for small and human-powered boats moving north or south along the pierhead line, the cruise ships would potentially block the view of whatever vessel or vessels might be headed in the opposite direction. Glare and lack of visibility due to weather conditions also pose a risk.	Devising of a monitoring and communication system with a couple of levels of redundancy: regular radio calls on channel 13 that take place at, say, 30, 15, 10 and 5 minutes before cruise ship landings and departures, for example.
40	DSNY and Manhattan Kayak	Communication between cruise ships and other vessel traffic is a constant risk for collision and vessel delays in the harbor and around MCT. Also, The Pier 84 public launch is open to the public, including visitors who may be unfamiliar with river currents, vessel traffic, and VHF protocols. Even with signage or outreach, visiting paddlers may inadvertently get trapped by these complex hazards.	Increase dialogue between all stakeholders within the harbor and implement training for uninformed users. Institute a standard operating procedure for communication while transiting by MCT to inform all users of vessel traffic movements.

# **Appendix B: HAZID Workshop Minutes**

**Table B-1: Stakeholder Engagement Workshops Conducted for the NSRA**

<b>Workshop Number</b>	<b>Workshop Date</b>	<b>Stakeholder Groups</b>
1	September 17, 2025	New York Harbor Commercial Operators
2	September 29, 2025	New York City Agencies
3	October 1, 2025	New York Harbor Ferry Operators
4	October 14, 2025	Human Powered Boaters
5	October 23, 2025	Adjacent Facilities and Other Users

## MCT NSRA – New York Harbor Commercial Operators Risks and Hazards Workshop Minutes

Meeting Date: September 17, 2025

Location: Sandy Hook Pilots Office

Present: Brian Henry, Donjon  
Russel Henchman, McAllister  
Brendan Collins, Moran  
Nathan Hauser, Moran  
John De Cruz, Sandy Hook  
Jim Mahlman, Sandy Hook  
Brian Rau, Vane  
Steve Lyman, MAPONY  
Jon Miller, Metro Pilots

NYCEDC  
Giacomo Landi  
Allison Dees  
Jackie Ting

Hatch  
Joshua Nelson  
Tomer Chen  
Spencer Robins

Purpose: Harbor Ops Risk and Hazards Workshop for MCT Navigation Safety Risk Assessment

### General Discussion

On September 17, 2025, NYCEDC convened a hazard and risk assessment workshop with representatives from the maritime industry in the New York / New Jersey Harbor regarding the Manhattan Cruise Terminal (MCT) Navigation Safety Risk Assessment (NSRA). Those that attended the meeting included representatives from pilots' associations who would be involved in navigating cruise ships on the Hudson River, towing companies who would be involved in cruise ship berthing and unberthing, dredging and bunkering companies, and those representing the overall interests of the commercial maritime industry in the region. Also in attendance were representatives from NYCEDC and Hatch.

After presenting the overall configuration of the proposed terminal, the participants were asked general questions regarding the NSRA as well as the effect that the proposed terminal will have on navigation in the area of the Hudson River around MCT. Below is a compilation of items that were discussed with the originator of the discussion point bolded.

- **Jon Miller** suggested that there would be a significant increase in current speed when entering the channel due to the proposed extensions. He also had particular interest in the structure of dolphins and fendering. He noted that cruise lines have had issues with leads on the mooring lines.

Mr. Miller was also interested in who is asking for longer piers at MCT? His argument was that there is sufficient mooring at the terminal to accommodate the current vessels. However, cruise lines don't have sufficient space for land-side support.

- **Brian Rau** noted that maneuvering barges into the terminal may become more difficult if Pier 90 will be removed, and that there shouldn't be any issue with special anchorages near MCT.
- **Brian Henry** noted that the dredging scows that go out into the channel will likely need larger tugs to combat increased current speed due to the increase of the length of the piers. This has the potential to increase cost for EDC for dredging projects.

- Russ Henchman noted that winter ice floes transit the navigation channel and may cause navigation issues that should be kept in consideration. He also noted that ship overhang between the waterline beam and extreme beam currently poses a challenge for barges conducting bunkering operations and may pose a greater risk with larger vessels.
- Jim Mahlman mentioned the cofferdam project on the Hudson River (the Hudson River Ground Stabilization Project associated with the Gateway Project), which started in 2024. It impacts navigation on the Hudson and would explain the dispersed AIS transit patterns data for cruise ships that had to navigate around the project.
- Steve Lyman Noted that the river is shallower on the NJ side and that this may cause increased congestion due to constriction of the river.
- Nathan Hauser was interested in how the customer experience will improve for those who use the new terminal. EDC noted that the entire Master Planning process includes a new terminal intended to make the passenger experience smoother and more efficient.

## Questions

Subsequent to discussions regarding the NSRA and the proposed redevelopment plan, the group transitioned into the hazard and risk identification portion of the workshop. This included a list of questions as shown below, organized into sections, for the attendees to answer.

Answers were written by attendees on notecards, which were later collected and have been compiled below. Attendees generally provided answers related to the overall topics in the various sections. Where specific questions were answered, they have been called out below. Due to time constraints, the workshop focused on sections 1 & 2 as well as solicitation of potential mitigation measures.

### 1. Maneuvering, Berthing, and Transiting Around MCT

1.1. Are there any specific navigational challenges you currently face in this section of the river?

- **Jim Mahlman** noted that there are strong currents present at MCT.
- **Jon Miller** noted that Hudson River Gateway Project currently poses a risk when navigating to MCT and that bow-first approach is preferred at MCT as there is more power in the stern of the cruise ships.
- **Russel Henchman** noted that there are strong currents present at MCT and high vessel traffic.

1.2. How do you expect the proposed MCT redevelopment project, as outlined in the presentation, to affect your operations?

- **Jim Mahlman** noted that the risk due to potential increase in current speeds while docking and undocking will become more acute with less maneuvering room in the river.
- **Brian Rau** also noted that there may be a risk associated with potential increased current speeds interacting with vessel traffic. He also noted that the demolition of Pier 90 would remove the pivot point making it harder to get bunker barges in and out from alongside the vessel, and that the proposed plan may reduce overall navigational room.

- **Jon Miller** did not see any issue with narrowing of the federal channel or challenges with navigation.
- **Nathan Hauser** suggested that larger tugs may be required for maneuvering operations at the terminal and more often.
- **Russel Henschman** noted that the cross-vessel current during maneuvering operations may increase and affect docking operations.

1.3. What specific concerns regarding vessel maneuverability or navigational safety do you have if the project were constructed as proposed?

- **Jim Mahlman** reiterated that there will be a constraint with maneuvering room and that the cruise ships will likely need to introduce transit windows around slack water
- **Brian Rau** reiterated the points of others in terms of concerns regarding maneuverability and navigability and also noted the potential risk of currents and eddies within the slips after construction. Another point of discussion was the increased weight and size of bunker barges necessary to service larger cruise ships that will potentially call at MCT, as well as the fact that there will potentially need to be more tugs to get alongside which may increase cost.
  - **Jon Miller** noted that human powered vessel traffic poses a hazard.

## 2. Impact of MCT Redevelopment and Narrowing of the Navigational Channel

2.1. How do you foresee the proposed redevelopment project impacting the safety or flow of traffic in this part of the river, particularly during high-traffic periods?

- **Jim Mahlman** indicated that he expects no impact to the safety or flow of traffic, except for impacts on human powered vessel traffic.
- **Brian Henry** also indicated that human powered vessel traffic may be impacted.
- **Nathan Hauser** had no concerns with the redevelopment proposal or the narrowing of the navigational channel.
- **Russel Henschman** noted that there likely wouldn't be too much of an issue regarding vessel traffic as there is sufficient space in the river.

2.2. What additional buffer, if any, would you require between the proposed project and the navigable channel to maintain safe operations?

- **Jim Mahlman** suggested that the piers, once constructed, are to be well lit and charted on the navigational charts.
- **Russel Henschman** suggested that the piers be highly visible with lighting installed.

2.3. What type of facility/infrastructure changes, operational modifications, or other investments might you need to make to operate in a narrower channel? If so, how likely is it that you will be able to make these investments in the short term (2 to 5 years)? In the longer term (greater than 5 years)?

- **Jim Mahlman** did not see the need for additional investment from Sandy Hook Pilots to modify operations.

2.4. How do you see emergency response operations changing as a result of the proposed redevelopment?

- **Jim Mahlman** did not see emergency response changing.
- 2.5. What additional safety requirements would you suggest in anticipation of transiting ships similar in size to the Icon Class and the pier extensions?
- **Jim Mahlman** strongly suggested that a real-time current sensor be installed at the end of the proposed piers.
  - **Jon Miller** suggested that the hydrodynamics at the terminal are to be assessed prior to construction.
  - **Russel Henchman** reiterated the suggestion of adding a current meter at the end of the proposed piers, as well as requiring that a fire boat or public safety vessel be on standby when there is human powered vessel traffic to monitor their movements and respond to emergencies.
- 2.6. What passing maneuverings (bow to bow, not overtaking, etc.) would be feasible in the channel with the increased height, length overall, and beam of the Icon Class-sized vessels?
- **Jim Mahlman** suggested that the same passing maneuvers as are currently in place be imposed in the future: no meet / no pass during docking and undocking.

### 3. Environmental or Other Operational Hazards

- 3.1. What risks associated with weather, current, tidal range, wind, visibility, ice, etc. might you expect with the proposed redevelopment?
- **Nathan Hauser** suggested that ice floes can present challenges associated with the risk of damage to infrastructure, clearing from berth before docking, and may impede vessel operations (although tugs are often used for clearing ice).
- 3.2. What type of challenges associated with communication with vessel traffic do you anticipate?
- Question not directly addressed by participants
- 3.3. What type of vessel or terminal security issues do you foresee?
- Question not directly addressed by participants

### 4. Mitigation Measures

- 4.1. Do you have any recommendations for design or operational mitigations that could reduce potential risks associated with the MCT redevelopment?
- **Jim Mahlman** suggested installing a camera system at the end of dolphins to see traffic up and down the river.
- 4.2. What, if any, additional Aids to Navigation would assist with transiting at MCT?
- Question not directly addressed by participants.
  - Is there anything else we should consider in the Navigation Safety Risk Assessment?
  - Question not directly addressed by participants.

## Risks

The risks and hazards that were identified during the workshop have been compiled in the table below, with their respective mitigation measures as applicable.

**Table B-2: HAZID Risk Register for Deep Draft and Commercial Vessel Operators and Pilots**

<b>Risk ID</b>	<b>Originator</b>	<b>Risk Description</b>	<b>Potential Mitigation Measures</b>
1	Jim Mahlman - Sandy Hook Pilots Jon Miller - Metro Pilots	Coming out into the channel at strength of current can be difficult when maneuvering cruise ship	Real-time current sensor at end of pier or on a buoy at the end of the dolphin. Optimization of vessel schedules within reason to reduce interaction with strong currents during departure.
2	Russ Henschman - Habor Pilots of NYNJ	With the piers located farther out, there's a concern that towing vessels may continue operating as they currently do—providing only brief assistance—rather than remaining made fast for longer durations. This could pose challenges for maneuvering vessels that require sustained towing support while approaching the berths.	Tug support upon approach. Optimization of vessel schedules within reason to reduce interaction with strong currents during maneuvers.
3	Brian Rau - Vane Brothers	Losing pivot point on Pier 90 if demolished, particularly with larger vessels and larger stems, may increase the potential to run out of room between cruise ships during maneuvering.	Schedule barge movements carefully. Maintain safe separation buffers. Utilize the increased basin space once constructed.
4	Jon Miller - Metro Pilots	How will the current change as a result of the infrastructure change?	Assessment of hydrodynamics of the proposed piers and their affect on the channel currents in future studies. Detailed hydrodynamic modelling and sedimentation in future studies.
5	Brian Rau - Vane Brothers	Current will continue to run through mooring dolphins and may cause unpredictable eddies and currents.	Assessment of hydrodynamics of the proposed piers and their affect on the waters within MCT.
6	Jon Miller - Metro Pilots	Increased prop wash may affect construction, shoaling, and scouring, particularly with those ships that moor at MCT for a long period of time.	Propwash induced current and scour assessment in future studies.
7	Brian Henry - Donjon	Scows are around 135' and there should be enough space at MCT, but coming out into the current could be difficult to maneuver.	Potential need for larger tugs to combat current speed.
8	Nathan Hauser - Moran	There is a risk of a support vessel (tug) losing power and being more exposed to vessel traffic and environmental factors since it is further into the Hudson. There is a risk that the vessels are more susceptible to emergency scenarios as they will be in the middle of the channel rather than tucked away closer to MCT.	Use larger or more tugs. Schedule movements during lower current periods, as possible.
9	Jon Miller - Metro Pilots Brian Rau - Vane Nathan Hauser - Moran	Usage of Hudson River area around MCT by human powered boaters. As the plan for the piers is to extend further into the channel, the human powered boaters will be more exposed to faster currents and potentially more unsafe conditions	Standby emergency response vessel during arrival and departure of cruise vessels. Safety vessel or standby vessel to collect people and human powered vessels in emergency scenarios. Dredge operations has a crew boat at all times for safety. Increased signage, awareness, and best practice instructions for human powered

Risk ID	Originator	Risk Description	Potential Mitigation Measures
			boaters at their origin and destination piers/docks.
10	Russ Henschman - Harbor Pilots of NYNJ	Contending with current for vessels responding to emergency scenarios.	increase on site emergency response capabilities with redeveloped terminal plan.
11	Jon Miller - Metro Pilots Jim Mahlman - Sandy Hook Pilots Brian Rau - Vane	Vessels may use South Pier dolphins as a pivot point during future operations. There is a risk that if the pier is not designed for this type of operation. As a result, the vessels could be damaged or cause damage to the infrastructure.	Take into account pivoting forces on South Pier dolphin for vessel entering into southern berth and apply appropriate fendering.
12	Brian Rau - Vane Brothers	Pier 90 is currently used as a bail out point during maneuvering of barges and removal of this pier may cause risk of contact incidents where there isn't a point for barge's to maneuver off of.	Additional tugs may be required for maneuvering barges into position at redesigned MCT.
13	Jon Miller - Metro Pilots	There is the potential that the piers are being overbuilt and over-extended into the channel, as there is sufficient mooring to accommodate the cruise ships currently.	Cruise ships need the additional pier infrastructure for landside support and access to aft hatches, particularly for the larger vessels. Also, cruise ships currently have issues with mooring line leads.
14	Russ Henschman - Harbor Pilots of NYNJ	Challenges with the extreme beams of ships overhanging onto the terminal areas and further constrict the space for support vessels to maneuver.	The majority of cruise ships expected in the future are already frequenting MCT, and there will be more space inside the main basin once the expansion is completed. Vessel-specific approach planning and increased tug support may be needed for largest vessels.
15	Steve Lyman - MAPONY	The Hudson River is shallower on the NJ side, so extending the piers further into the Hudson will force cruise ship and other vessel traffic towards the NJ side and may increase potential risk of groundings.	The spatial extent of vessel route offsets are not expected to drive deep draft vessels beyond a limit where there is sufficient under keel clearance in the main channel, or appreciably change route patterns in shallow areas on the New Jersey side. Updated bathymetry survey and/or monitoring and increased pilot awareness through NTMs.

## MCT NSRA – NYC Agencies Risks and Hazards Workshop Notes

Meeting Date: September 29, 2025

Location: NYCEDC Offices

Present: Sean Fitzgerald, FDNY Marine  
Keith Nebel, FDNY Marine  
Jason Ronayne, FDNY Marine  
Phil Marino, FDNY Marine  
Luis Ramirez, NYPD Harbor Unit  
Mark Landi, NYPD Harbor Unit  
Brian Kelly, NYC DEP  
Johnwis Garcia, NYC DEP  
Nate Grove, NYC Parks  
Christopher Ameigh, NYC Parks

NYCEDC  
Giacomo Landi  
Allison Dees  
Jackie Ting  
Sudhir Puthran  
Tara Das

Hatch  
Joshua Nelson  
Tomer Chen  
Spencer Robins

Purpose: NYC Agencies Risk and Hazards Workshop for MCT Navigation Safety Risk Assessment

### General Discussion

On September 29, 2025, NYCEDC convened a hazard and risk assessment workshop with representatives from various New York City government agencies regarding the Manhattan Cruise Terminal (MCT) Navigation Safety Risk Assessment (NSRA). Those that attended the meeting included representatives from the New York Police Department (NYPD), Fire Department of New York (FDNY), New York City Department of Parks and Recreation (“Parks”), and the New York City Department of Environmental Protection (DEP). Also in attendance were representatives from NYCEDC and Hatch.

After presenting the overall configuration of the proposed terminal, the participants were asked general questions regarding the NSRA as well as the effect that the proposed terminal will have on navigation in the area of the Hudson River around MCT. Below is a compilation of items that were discussed with the originator of the discussion point bolded.

- NYPD:
  - ◆ NYPD have a 35-foot boat assigned to Pier 86. To get into that boat, personnel have to climb a ladder, providing limited access in the winter on the Hudson. In a future terminal design, the department has requested that accommodation be made for their vessels with lower freeboard for emergency situations, like ladders.
  - ◆ NYPD personnel discussed evacuation procedures in case of a fire, security breach, or other emergency at the terminal.
- FDNY:

- ◆ FDNY noted that, in the event of an emergency, they would require space to moor their fire boat, the “Three Forty Three,” to provide water to the terminal. They would also require accessibility for smaller boats to shuttle medical personnel and responding to medical emergencies. They likely need one landing point at each of the new piers for the 140-foot boat in case of a fire, with the north side of the north pier appearing to provide sufficient access in the planned configuration.
- Parks:
  - ◆ Had no specific comments regarding the NSRA.
- DEP:
  - ◆ Had no specific comments regarding the NSRA.

## Questions

After discussions regarding the NSRA and the proposed redevelopment plan, the group transitioned into the hazard and risk identification portion of the workshop. This included a list of questions as shown below, organized into sections, for the attendees to answer.

Answers were written by attendees on notecards, which were later collected and have been compiled below. Attendees generally provided answers related to the overall topics in the various sections. Where specific questions were answered, they have been called out below.

### 1. Maneuvering, Berthing, and Transiting Around MCT

- 1.1. What do typical operations around MCT look like for your agency? Are there any specific interactions between MCT and your nearby facilities or operations?
  - **FDNY** accesses the facility from the water during an emergency, as it is the most efficient way of getting people into the facility, but they noted that the current arrangement is not conducive for emergency response. They also do ship familiarization exercises at the terminal and respond to traffic accidents, fires, and medical emergencies. FDNY operates a 140-foot fire boat and several 33-foot aluminum rescue boats that need mooring, personnel, and fire equipment access at the terminal.
  - **NYPD** currently does routine patrol from the waterside at MCT.
  - **DEP** noted limited interaction with MCT, but that their vessels transit the Hudson to their North River Plant.
  - **Parks** noted no direct interactions with MCT.
- 1.2. Are there any specific navigational challenges you currently face in this section of the river?
  - **FDNY and DEP** identified increased scheduled ferry traffic as a navigation hazard in the area.
  - **NYPD** noted that at night it is difficult to see human powered vessel users and could be a hazard on the river, particularly for vessels berthing and unberthing.

### 2. Impact of MCT Redevelopment

- 2.1. How do you expect the proposed MCT redevelopment project, as outlined in the presentation, to affect your operations?

- **FDNY** suggested that there would be a minimal delay in responding to emergencies at the redeveloped terminal (on the order of 30 seconds). That said, they noted that they will need mooring points on dolphins and bulkheads. Their response tactic for the 140-foot vessel would have to adapt, and operations such as access, boarding, and person removal will have to change. They also suggested that increased currents towards the center of the channel will make mooring more challenging.
  - **NYPD** personnel did not see the redevelopment proposal affecting their operations.
- 2.2. What specific concerns regarding emergency response do you have if the project were constructed as proposed, and how do you see emergency response changing?
- **FDNY** noted that their standard operating procedures would likely have to be continuously modified and personnel familiarized during construction phasing.
  - **NYPD and FDNY** inquired as to where will people go in case of an emergency at the terminal or onboard a vessel calling at the terminal.
- 2.3. How do you foresee the proposed redevelopment project impacting the safety or flow of traffic in this part of the river, particularly during high-traffic periods?
- **DEP** suggested that informing the public of the new channel development would be necessary.
- 2.4. What type of operational modifications or other investments might you need to make for any emergency operations at the redeveloped terminal? If investments are required, how likely is it that you will be able to make these investments in the short term (2 to 5 years)? In the longer term (greater than 5 years)?
- **DEP** did not see any need for additional investment on their end.
  - **FDNY** suggested a dedicated command post at the terminal. They also specifically indicated that their existing vessels paired with a landside response would be sufficient to handle emergencies at the terminal.
- 2.5. What additional safety requirements would you suggest?
- **FDNY** suggested installation of dry pipe standpipe manifolds for provision of water during fires, which would help in case one of the fire boats was having trouble docking at one of the other pier locations. They also suggested installation of fire hydrants over the length of the terminal piers.
  - **DEP** suggested including aids to navigation, signage on dolphins, and warning signs to keep public out.
- 2.6. How do you anticipate the proposed redevelopment to affect recreational vessel traffic transiting around MCT?
- **NYPD** noted that the redevelopment may create additional interaction with jet skis.
  - **Parks** suggested increased usage by kayakers, stand-up paddleboards, etc.
- 3. Environmental or Other Operational Hazards**
- 3.1. What risks associated with weather, current, tidal range, wind, visibility, ice, etc. might you expect with the proposed redevelopment?
- **Parks** noted that the extended reach of the piers into the channel, combined with the absence of upstream piers to initiate icebreaking, can lead to significant challenges. Ice

floes may pose risks to infrastructure, complicate berth clearance prior to docking, and potentially disrupt vessel operations. **NYPD** did not think this would be an issue.

- **NYPD and FDNY** both noted that the tidal ranges on the Hudson and the low freeboard of some of their vessels should be taken into account when considering access to the terminal.
- 3.2. What type of challenges associated with communication with vessel traffic do you anticipate?
- **DEP** noted that there will likely be many construction vessels during construction phasing and that VTS and Local Notices to Mariners will likely need to be continuously updated.
  - **NYPD** did not foresee communication issues.
- 3.3. What type of vessel or terminal security issues do you foresee?
- **NYPD** noted that limited waterside access for emergency personnel during a security emergency could be a risk.
  - **DEP** suggested that enforcement of a security zone will be a challenge.

#### 4. Mitigation Measures

- 4.1. Do you have any recommendations for design or operational mitigations that could reduce potential risks associated with the MCT redevelopment?
- **DEP** suggested that mooring dolphins and piers be well lit for visibility, and creation of a new traffic pattern around the terminal. They also suggested reaching out to Port Authority Police Department for additional security zone enforcement, as well as designating a dedicated VTS operator for the terminal during the construction process and a “slow speed” designation.
  - **NYPD** personnel suggested creating “frozen zones.”
  - **FDNY** suggested that NYCEDC send updates to agencies throughout the construction phasing process to provide information on accessibility.
  - **Parks** suggested providing updates on construction phasing to other organizations, like Fleet Week, so that they have enough time to plan ahead if necessary.
- 4.2. Is there anything else we should consider in the Navigation Safety Risk Assessment?
- **NYPD** personnel suggested meeting with local kayaker organizations and jet ski organizations (Marine Task Force).

## Risks

The risks and hazards that were identified during the workshop have been compiled in the table below, with their respective mitigation measures as applicable.

**Table B-3: NYC Agencies Risk Register**

Risk ID	Originator	Risk Description	Potential Mitigation Measures
1	FDNY	Increased scheduled ferry traffic over time may cause issues for emergency response vessels accessing the terminal in an emergency.	Increased coordination between ferry schedules and emergency operations.

<b>Risk ID</b>	<b>Originator</b>	<b>Risk Description</b>	<b>Potential Mitigation Measures</b>
2	New York Parks NYPD	Commercial vessel traffic interaction with human-powered vessel traffic has the increased risk of casualties and collisions.	Stakeholder outreach; dedicated kayak zones; warnings during commercial and cruise ship arrivals, additional communication measures between kayakers and commercial vessel users through marine radios.
3	New York Parks	With the present pier configurations, upstream piers are able to break ice flows. There is an increased risk of vessels colliding with bergs with the new pier configuration that extends further into the channel.	Increased ice monitoring; schedule movements to avoid ice flows; timely ice-breaking measures.
4	NYC Department of Environmental Protection NYPD FDNY	Increased number of construction vessels at the terminal during construction activities will increase risk of collisions, allisions, and groundings	VTS will need to provide updates regarding vessel traffic, surveys, diving at the terminals, with potential to designate specific person to control area. USCG will have to provide Local Notices to Mariners. NYPD also suggested creating "frozen zones" while the project is ongoing.
5	NYPD	In the summer months particularly, jet ski traffic increases considerably.	Stakeholder outreach with jet ski clubs and businesses, as well as Jersey Marine Task Force, to discuss mitigation measures.
6	NYC Department of Environmental Protection	Extending the piers into the channel poses an increased risk for allisions.	Lighting at the ends of the piers, additional aids to navigation, signage on dolphins, warnings to keep public out.
7	FDNY	With longer piers, there is an increased risk of allision at the terminal.	Enforcement of an exclusion zone around the extended piers to have background traffic avoid it at a specified offset distance.
8	FDNY	FDNY needs access to water supply during construction phasing and after construction is completed during emergencies.	Ensure that there are locations for the "Three Forty Three" to tie up, and a dry pipe standpipe system at the piers with manifold will allow FDNY to supply piers with water.
9	FDNY	If there is an emergency on the vessel or at the terminal, there is an increased risk associated with evacuating people.	Emergency response plans/drills, designated evacuation routes, dedicated safety vessels standby.
10	NYC Department of Environmental Protection	Without increased vessel security waterside, there likely will be an increased risk of incidents and breaches.	Security zone enforcement, with potential engagement of port authority police department.

## MCT NSRA – New York Harbor Ferry Operators Risks and Hazards Workshop Minutes

Meeting Date: October 1, 2025

Location: NYC EDC Offices

Present: NY Harbor Ferry Operators  
Bill Buckley, Hornblower  
Gordon Loebel, NYC Ferry  
Alan Warren, NY Waterway  
Donald Liloia, NY Waterway

NYCEDC  
Giacomo Landi  
Allison Dees  
Jackie Ting  
Sudhir Puthran

Hatch  
Joshua Nelson  
Tomer Chen  
Spencer Robins

Purpose: NY Harbor Ferry Operators - Risk and Hazards Workshop for MCT Navigation Safety Risk Assessment

### General Discussion

On October 1, 2025, NYCEDC convened a hazard and risk assessment workshop with representatives from various New York harbor ferry operators regarding the Manhattan Cruise Terminal (MCT) Navigation Safety Risk Assessment (NSRA). Those that attended the meeting included representatives from Hornblower, NY Waterway, and NYC Ferry. Also in attendance were representatives from NYCEDC and Hatch. New York Cruise Lines was invited but could not attend the workshop.

After presenting the overall configuration of the proposed terminal, the participants were asked general questions regarding the NSRA as well as the effect that the proposed terminal will have on navigation in the area of the Hudson River around MCT. Below is a compilation of items that were discussed with the originator of the discussion point bolded.

- NY Waterway:
  - ♦ **NY Waterway** estimated that the cruise ship calls only affect their operations 430 hours per year. They were also amenable to accommodating other cruise ships as NY Waterway provides parking for passengers coming from New Jersey and also provides excursions for cruise ship passengers. To facilitate efficient planning of ferry schedules, they suggested being informed of cruise ship schedules ahead of time. This would allow ferry operators to reroute their vessels around the cruise ships, thus mitigating future casualty risks.
  - ♦ They also inquired about the 2D Desktop Navigation Simulation and how the extent of the ships into the channel affect vessel traffic, particularly during cruise ship unberthing maneuvers. They noted that ferries typically stay as close as possible to the New Jersey shoreline, and that their traffic patterns will likely have to change with the cruise ships extending further into the channel.
  - ♦ Representatives noted previous deauthorization initiatives in the Hudson River Federally Authorized Navigation Channel.

- Neither representatives from Hornblower or NYC Ferry had comment in this section.

## Questions

After discussions regarding the NSRA and the proposed redevelopment plan, the group transitioned into the hazard and risk identification portion of the workshop. This included a list of questions as shown below, organized into sections, for the attendees to answer.

Answers were written by attendees on notecards, which were later collected and have been compiled below. Attendees generally provided answers related to the overall topics in the various sections. Where specific questions were answered, they have been called out below.

### 1. Maneuvering, Berthing, and Transiting Around MCT

- 1.1. What do typical operations around MCT look like for you? What are the specific interactions between MCT, your vessels, and your nearby facilities and operations?
  - **Hornblower** reported that they don't have any current operations in the area.
  - **NYC Ferry** also indicated that they don't currently have operations in the area.
  - **NY Waterway** noted that they have ferry landing at Pier 79, in Weehawken, and in Hoboken at 14<sup>th</sup> St. and Lincoln Harbor, and that they have their homeport across the river in Weehawken as well. NY Waterway ferries typically stay close to the New Jersey shoreline, but stay a minimum of approximately 1,000 feet off the shore for casualty mitigation purposes due to shallower water on the New Jersey side. Currently, their Edgewater route ferries typically stay 1/3 of the width of the channel off of the NY shoreline.
- 1.2. Are there any specific navigational challenges you currently face in this section of the river?
  - **NY Waterway** noted that the current typically is in an ebb flow during their ferry transits, which is something their operators have to deal with when routing around other vessels. They also noted that they typically interact with cruise ships in the afternoon when the cruise ships unberth.

### 2. Impact of MCT Redevelopment

- 2.1. How do you expect the proposed MCT redevelopment project, as outlined in the presentation, to affect your operations?
  - **Hornblower** suggested that if there was a ferry terminal added to the north side of the north pier, that NYC Ferry would likely call there on a limited basis at EDC's discretion. They also noted that passenger ferries are highly maneuverable, so they don't expect major impact to their operations.
  - **NY Waterway** noted that their ferry operators would likely have to transit closer to the center of the channel and that their schedules may have to change.
- 2.2. What specific concerns regarding emergency response do you have if the project were constructed as proposed, and how do you see emergency response changing?
  - Neither **Hornblower** nor **NY Waterway** commented on this question.
- 2.3. How do you foresee the proposed redevelopment project impacting the safety or flow of traffic in this part of the river, particularly during high-traffic periods?

- **NY Waterway** indicated that the narrowed channel could potentially impact vessel traffic flow.
- 2.4. What type of operational modifications or other investments might you need to make for any emergency operations at the redeveloped terminal? If investments are required, how likely is it that you will be able to make these investments in the short term (2 to 5 years)? In the longer term (greater than 5 years)?
- **NY Waterway** noted that they are currently in the process of developing a new pier and breakwater at their yard in Weehawken. They indicated that they would potentially have to make an adjustment to their plans to take into account cruise ship traffic potentially extending further to the West side of the river.
  - What additional safety requirements would you suggest?
  - **NY Waterway** indicated that it would be easier and more efficient to plan ferry routes if cruise ship call timing and schedules were known in advance.
- 2.5. How do you anticipate the proposed redevelopment to affect recreational vessel traffic transiting around MCT?
- **NY Waterway** noted that there are many tour boats that transit close to the New York side of the river, which should be accounted for. They also noted that the redevelopment may cause vessel delays or impacts to vessel schedules in general.
- 3. Environmental or Other Operational Hazards**
- 3.1. What risks associated with weather, current, tidal range, wind, visibility, ice, etc. might you expect with the proposed redevelopment?
- **NY Waterway** suggested that ice floes could affect berthing at MCT.
- 3.2. What type of challenges associated with communication with vessel traffic do you anticipate?
- **NY Waterway** noted that fog (visibility) could affect vessel traffic in general, but that VTS currently broadcasts related updates.
- 3.3. What type of vessel or terminal security issues do you foresee?
- **NYC Ferry** noted that the maritime security zone around MCT is not typically enforced.
- 4. Mitigation Measures**
- 4.1. Do you have any recommendations for design or operational mitigations that could reduce potential risks associated with the MCT redevelopment?
- **NY Waterway** suggested implementing a slow bell for vessels transiting near MCT during construction phases, and for VTS to provide supplemental broadcasts with notices of departure of cruise ships. They also suggested that the USCG could implement public outreach through their inspectors to inspected vessels regarding input to the NSRA.
- 4.2. Is there anything else we should consider in the Navigation Safety Risk Assessment?
- Neither Hornblower nor NY Waterway commented on this question.

## Risks

The risks and hazards that were identified during the workshop have been compiled in the table below, with their respective mitigation measures as applicable.

**Table B-4: New York Harbor Ferry Operators HAZID Risk Register**

<b>Risk ID</b>	<b>Originator</b>	<b>Risk Description</b>	<b>Potential Mitigation Measures</b>
1	NY Waterway	Future pier and breakwater at Weehawken Yard to extend 100/200 feet off of the New Jersey pier headline, which may further encroach on the navigable channel and impact vessel traffic.	Future analyses related to the Proposed Project should include how the NY Waterway yard redevelopment will also affect vessel operations on the Hudson.
2	NY Waterway	Currently, NY Waterway doesn't receive arrival or departure schedules, which causes increased risk of collision since they can't plan efficiently.	Suggested that VTS provide supplemental broadcasts with notices of arrival and departure of cruise ships.
3	NY Waterway	Risk to visibility that may increase casualties.	VTS currently provides adequate updates.
4	NY Waterway	Impact of construction phasing on vessel traffic may increase risk of allisions or collisions.	NY Waterway suggested VTS to implement slow bell in area, and they also suggested that the USCG could implement public outreach through their inspectors to inspected vessels regarding input to the NSRA.

## MCT NSRA – New York Harbor Human Powered Boaters Risks and Hazards Workshop Minutes

Meeting Date: October 14, 2025

Location: NYC EDC Offices

Present: NY Harbor Human Powered Boater Representatives  
Maggie Flanagan, Harbor Ops. Education Subcommittee  
Martin Sweeney, Downtown Boathouse  
Julie Rwan, President, New York Outrigger  
Carter Craft, Managing Member, Outside New York  
Eva Rivlin, New York City Water Trail Association (Virtual attendee)  
Suzy Basu, Manhattan Kayak Company (Virtual attendee)  
Eric Stiller, Owner, Manhattan Kayak Company (Virtual attendee)  
Jay Cartagena, Manhattan Kayak Company (Virtual attendee)

NYCEDC  
Giacomo Landi  
Allison Dees  
Jackie Ting  
Sudhir Puthran  
Tara Das

Hatch  
Joshua Nelson  
Tomer Chen  
Spencer Robins

Purpose: NY Harbor Human Powered Boaters - Risk and Hazards Workshop for MCT Navigation Safety Risk Assessment

### General Discussion

On October 14, 2025, NYCEDC convened a hazard and risk assessment workshop with representatives from various New York harbor human powered boater operators and interest groups regarding the Manhattan Cruise Terminal (MCT) Navigation Safety Risk Assessment (NSRA). Those that attended the meeting in person included representatives from the Harbor Ops (HOPS) Education Subcommittee, New York Outrigger, and Downtown Boathouse. Representatives from the New York City Water Trail Association (NYCWTA) and Manhattan Kayak Company also attended virtually, and a representative from Outside New York attended for the first half of the meeting. Also in attendance were representatives from NYCEDC and Hatch.

After presenting the overall configuration of the proposed terminal, the participants were asked general questions regarding the NSRA as well as the effect that the proposed terminal will have on navigation in the area of the Hudson River around MCT. Below is a compilation of items that were discussed with the originator of the discussion point bolded.

- HOPS Education Subcommittee:

- ◆ Suggested accommodation of historical ships and tall ships, such as the “Grain du Sail” sailing cargo ship, for tying up on the north side of the future North Pier.
- ◆ Stressed that future design considerations should allow for various types of vessels to berth, including historical vessels, and referenced Piers 15, 17 and West Harlem Piers as examples of “hostile” infrastructure.
- ◆ Suggested that the future dredging plan should include auxiliary piers on the north side of the future North Pier to accommodate other users.
- Downtown Boathouse:
  - ◆ Also suggested consideration of accommodation of historical vessels tying up on the north side of the North Pier.
  - ◆ Wanted to understand how the maritime security zone around MCT will change in redeveloped plan.
- NY Outrigger:
  - ◆ Inquired as to how the additional 650-foot extension of the piers in the proposed plan compares to the current footprint, and whether it would just be Piers 88, 90, and 92 that are affected.
- Netherlands Consulate:
  - ◆ Was interested to understand what the current maintenance dredging operations are and how that is expected to change in the future.
- NYCWTA:
  - ◆ Asked whether the redevelopment proposal considers an increase in annual vessel traffic and berthing at MCT.

## Questions

After discussions regarding the NSRA and the proposed redevelopment plan, the group transitioned into the hazard and risk identification portion of the workshop. This included a list of questions as shown below, organized into sections, for the attendees to answer.

Answers were written by attendees on notecards, which were later collected and have been compiled below. Attendees generally provided answers related to the overall topics in the various sections. Where specific questions were answered, they have been called out below. Carter Craft of Outside New York departed after the first part of the meeting and was not present during the HAZID portion.

### 1. Current Usage and Operations Around MCT

1.1. What is your name and what organization do you represent?

- **Maggie Flanagan** is the Vice Chair of the Harbor Ops Education Subcommittee, and also represents the Harbor Estuary Group and Classic Harbor Lines.
- **Martin Sweeney** represents Downtown Boathouse
- **Julie Rwan** represents New York Outrigger
- **Jay Cartagena** is the General Manager and lead guide for Manhattan Kayak Company

- **Suzy Basu** represents Manhattan Kayak Company
  - **Eric Stiller** is the Owner of the Manhattan Kayak Company
  - **Eva Rivlin** represents New York City Water Trail Association (NYCWTA)
- 1.2. What type of recreational activities does your organization/users engage in on the Hudson River?
- **HOPS Education Subcommittee** coordinates maritime events, regattas, and safe boating programs.
  - **Downtown Boathouse** provides free kayaking from Pier 26 Hudson River Park and Governors Island.
  - **New York Outrigger** provides outrigger canoe paddling (1 person, 2 person, and 6 person) and stand-up paddle boarding out of Pier 96. They also provide free lessons and low-cost coaching.
  - **Manhattan Kayak Company** provides daily waterfront programming out of Pier 84, as well as stores boats for private human powered boaters.
  - **NYCWTA** advocates for paddling and rowing throughout NYC.
- 1.3. How frequently do your users utilize the area of the Hudson River near MCT for recreational purposes?
- **HOPS Education Subcommittee** coordinates safe boating programs (about 1 per month in the spring, summer, and fall), and have marine events in the summer.
  - **Downtown Boathouse** conduct volunteer trips that pass MCT around 6 times per year.
  - **New York Outrigger** noted that paddlers operate on this area of the Hudson up to 6 days a week through the organization. There is also a public launch at the park that anyone can use at any time. For introductory sessions, paddlers typically stay within Pier 96 watershed, while more experienced users traverse across the entire river.
  - **Manhattan Kayak Company** organizes 1-3 beginner trips per day across MCT and run 4 trips per day on weekends, which includes 1 trip for intermediate/expert kayakers.
  - **NYCWTA** paddlers operate daily from May to November and occasionally from December to April.
- 1.4. What time of year and/or time of day do your users typically use this section of the river?
- **HOPS Education Subcommittee** did not specifically answer this question.
  - **Downtown Boathouse** main operations are from May to October during daylight hours.
  - **New York Outrigger** main operations are from May to October, 6 days a week. They operate 1 day per week from November to April.
  - **Manhattan Kayak Company** from May 1 to November 1 organizes 1-3 beginner trips per day across MCT and run 4 trips per day on weekends, which includes 1 trip for intermediate/expert kayakers.
  - **NYCWTA** paddlers operate daily from May to November and occasionally from December to April, predominantly during daytime/evening hours.

- 1.5. What are your users' typical routes and how far off of the Manhattan shoreline do they typically transit?
- **HOPS Education Subcommittee** operators typically transit relatively close to Manhattan pierhead line, though wide enough to accommodate security zones.
  - **Downtown Boathouse** paddlers typically transit close to Manhattan side of the river, but also go to New Jersey side.
  - **New York Outrigger** paddlers transit the entire width of the river from the top of Manhattan to Sandy Hook. Depending on the current or tides, boats may be a few feet from shore or in the middle of the channel.
  - **Manhattan Kayak Company** paddlers typically go north because Pier 79 has historically been a safety hazard. They are typically out towards the center of the channel.
  - **NYCWTA** paddlers typically stay out of the center of the channel when possible and are typically within 100-200 yards of the pier/shoreline for safety.
- 1.6. Do your users launch or land their vessels near MCT? If so, where?
- **HOPS Education Subcommittee** operators use Pier 84 to support events.
  - **Downtown Boathouse** does not have paddlers that launch near MCT.
  - **New York Outrigger** paddlers launch from Pier 96.
  - **Manhattan Kayak Company** paddlers launch from Pier 84.
  - **NYCWTA** paddlers typically launch from Pier 84 and 96 and from Hoboken. The 79<sup>th</sup> Street Boat Basin is another nearby launch site, and additional sites exist further south along the Manhattan and NJ shores.
- 1.7. Are there any specific waterside navigational challenges your users currently face in this section of the river?
- **HOPS Education Subcommittee** indicated that the current in the channel can be an issue if not respected or planned for adequately, and that human powered vessels are generally bound by the current.
  - **Downtown Boathouse** indicated that the USCG security zone around MCT and the ferry terminals on the New Jersey side pose the biggest waterside navigational challenges.
  - **New York Outrigger** noted that the strong currents in the channel can be a safety issue. They also noted that because of the USCG security zone around MCT, paddlers have to stay closer to the center of the channel and away from the more protected waters of shore, which can be a challenge. They noted that having a cruise ship berthed at MCT actually helps them with their navigation as it provides a visual cue.
  - **Manhattan Kayak Company** indicated that ferries traffic and strong currents are navigational challenges in this area of the Hudson.
  - **NYCWTA** noted that the primary navigational challenge around MCT is incoming/outgoing traffic.
- 1.8. How do your users typically operate when encountering larger vessels, like cruise ships?

- **HOPS Education Subcommittee** noted that it is usually fairly clear how larger vessels, particularly cruise ships, will maneuver during transit, so paddlers can take necessary precautions. Whereas with ferries, tugs, and other smaller vessels, they tend to maneuver faster and less predictably. This can be a challenge since VHF radios only work through line of sight, so their communications to other smaller vessels may be blocked by larger ships in the way.
- **Downtown Boathouse** noted that paddlers will stand down and defer to larger vessels. Their paddlers will always monitor VHF Channel 13 and provide a security call at the start of their transits indicating number of boats in the convoy, departure point, and destination.
- **New York Outrigger** noted that paddlers avoid routes near berthing/unberthing cruise ships and that their paddlers have fairly minimal interaction with cruise ships in general. Typically, if they see a cruise ship, they will paddle north or across to the NJ side of the river.
- **Manhattan Kayak Company** indicated that their paddlers typically communicate via VHF radio to larger vessels and have indicated that cruise captains have generally been responsive. Conversely, they indicated that it is more challenging to communicate with support vessels and sometimes do not get response from tug and barge operators.
- **NYCWTA** noted that cruise ship traffic is not as much of an issue for them, but that the choke point that cruise ships create can cause increased congestion and increased interaction with tugs and barges and ferry traffic.

## 2. Impact of MCT Redevelopment

2.1. How would the proposed MCT redevelopment affect the routes your users take on the water?

- **HOPS Education Subcommittee** did not answer this question directly.
- **Downtown Boathouse** brought up the concern that the redeveloped pier structures may potentially make the remaining width of the Hudson River Channel more congested.
- **New York Outrigger** noted that there is the potential that they significantly limit southbound routes from Pier 96 as the channel narrows and the potential hydrodynamic effects of the piers pose a hazard for human powered vessels to be sucked under the piers. There is also the concern of bottlenecking of traffic due to constricting of the channel, as well as increased collision risk with motorized and human-powered vessels.
- **Manhattan Kayak Company** did not answer this question directly.
- **NYCWTA** noted that the extension of the piers would potentially heighten the risk of potentially dangerous interactions with other larger vessels by pushing more traffic into a narrower channel.

2.2. What specific concerns regarding emergency response do you have if the project were constructed as proposed, and how do you see emergency response changing?

- **HOPS Education Subcommittee** suggested that there should be specific emergency response plans that specifically address rescue of paddlers around pier structures.
- **Downtown Boathouse** did not directly answer this question.

- **New York Outrigger** did not directly answer this question.
  - **Manhattan Kayak Company** suggested creating more streamlined protocols for communicating with other vessels transiting the area.
  - **NYCWTA** noted that as the Hudson is the most accessible river for paddlers in the area, there are often groups passing through from further launch sites, who may be less familiar with regular traffic patterns around MCT, which can pose a challenge for emergency response.
- 3. Environmental or Other Operational Hazards**
- 3.1. What risks associated with weather, current, tidal range, wind, visibility, ice, etc. might you expect with the proposed redevelopment?
- **HOPS Education Subcommittee** did not directly answer this question.
  - **Downtown Boathouse** did not directly answer this question.
  - **New York Outrigger** mentioned that piles generally create a suctioning effect as the currents flow through them; they suggested that this effect under the extended piers may pose an issue to human powered boats travelling nearby.
  - **Manhattan Kayak Company** agreed that the hydrodynamic effect through the new piles and at the end of the piers might change as a result of the redevelopment.
  - **NYCWTA** did not directly answer this question.
- 3.2. What type of challenges associated with communication with vessel traffic do you anticipate?
- **HOPS Education Subcommittee** did not directly answer this question.
  - **Downtown Boathouse** suggested fostering better communication between human powered boaters and commercial vessel operators.
  - **New York Outrigger** did not directly answer this question.
  - **Manhattan Kayak Company** suggested creating more streamlined protocols for communicating with other vessels transiting the area.
  - **NYCWTA** did not directly answer this question.
- 4. Mitigation Measures**
- 4.1. What features or design elements would make the proposed redevelopment more compatible for recreational users transiting by MCT?
- None of the human powered boater operators answered this question specifically, but all participants agreed that the extended pier structures should be designed to take into account hydrodynamic effects of the current going through the piles.
- 4.2. What suggestions do you have for improving the safety of interactions between recreational and commercial users in this area?
- **HOPS Education Subcommittee** suggested that the extended piers should have lighting installed to make them clear for all boaters and to foster better communication between human powered boaters and commercial vessel operators.

- **Downtown Boathouse** suggested fostering better communication between human powered boaters and commercial vessel operators. They also suggested that NYCEDC get involved in Shared Harbor Day in 2026.
- **New York Outrigger** suggested providing better training to human powered boaters.
- **Manhattan Kayak Company** suggested creating more streamlined protocols for communicating with other vessels transiting the area.
- **NYCWTA** did not directly answer this question.

4.3. Is there anything else we should consider in the Navigational Safety Risk Assessment?

- None of the human powered boater operators had specific comments regarding this question.

## Risks

The risks and hazards that were identified during the workshop have been compiled in the table below, with their respective mitigation measures as applicable.

**Table B-5: Human Powered Vessel Operator HAZID Risk Register**

Risk ID	Originator	Risk Description	Potential Mitigation Measures
1	NY Outrigger	The potential for extended piers and increased boundary of the USCG security zone will likely cause paddlers to have to stay closer to the center of the channel and away from the more protected waters of shore, which increases the risk of casualties for human powered boaters.	Establishing a human-powered boating corridor that is physically marked by buoys or signage outside of the main navigation channel and outside of the USCG MSZ.
2	NY Outrigger	Fast moving boats who don't communicate adequately via VHF can increase the risk of casualties.	Streamline communication via VHF radio between all vessel operators.
3	HOPS Education Subcommittee	A lack of lighting on the dolphins increases the risks of casualties.	Installation of lighting on dolphins for redeveloped pier structure to ensure that casualties are kept at a minimum.
4	NY Outrigger	The mooring dolphins extending into the faster currents towards the center of the channel have the potential to create a hydrodynamic straining affect that can potentially cause harm to recreational boaters transiting in the area.	It is recommended that a hydrodynamic analysis of the mooring dolphins and pier infrastructure be conducted in the future to understand the effect these structures will have on the water moving past MCT. Future design of these structures should consider the hydrodynamic analysis to ensure that unpredictable currents and straining affects are reduced.

Risk ID	Originator	Risk Description	Potential Mitigation Measures
5	Manhattan Kayak Company	Piers 76 to 99 forms a uniform shoreline that allows cruise ships, tugs, barges, ferries, dinner boats, yachts, speedboats, jet skis, sailboats, and paddlers to travel in roughly parallel paths up and down the river. Smaller, slower traffic—such as paddlers—most often keep outside the main navigation channel, and therefore out of the way of larger boats. Extending some pierheads would break that alignment and force all vessels to shift course around new obstructions, creating choke points, increasing concentration of vessel traffic around the terminal, and increasing collision risk.	Establishing a human-powered boating corridor that is physically marked by buoys or signage outside of the main navigation channel and outside of the USCG MSZ.
6	Manhattan Kayak Company	Longer piers would block sightlines, especially after dark or during sunset glare. Paddlers use white lights, but other vessels may not see them in time. Many vessels are not monitoring VHF, and even when they are, large steel cruise ships can block line-of-sight radio signals between boats on opposite sides. A past ferry/kayak collision off Pier 76 showed how sun glare and missed radio communication can combine to cause serious accidents.	Using a red/green hold up/proceed flag system could be deployed and possibly echoed with a similar flag or light system atop the outermost dolphins.
7	Manhattan Kayak Company	New structures extending far into the river would alter the tidal flow, forcing currents to accelerate around them and creating suction zones. This, combined with turbulent eddies, can capsize, trap, or crush paddlers against structures.	It is suggested that a hydrodynamic analysis of the pier extensions with a cruise ship at berth be conducted in the future.
8	Manhattan Kayak Company	Cruise-ship support tugs often maneuver without open radio calls, backing and pivoting near the pierheads to dock, undock, and position barges. Extending the piers would leave paddlers less room to stay clear of these operations, forcing them closer to the main navigation channel, where conditions are rougher due to vessel traffic, wakes, and wind.	It is recommended that a hydrodynamic analysis of the mooring dolphins and pier infrastructure be conducted in the future to understand the effect these structures will have on the water moving past MCT. Future design of these structures should consider the hydrodynamic analysis to ensure that unpredictable currents and straining affects are reduced.

**MCT NSRA – Adjacent Facilities to MCT and Other New York Harbor Users Risks and Hazards  
Workshop Minutes**

Meeting Date: October 23, 2025

Location: NYC EDC Offices

Present: NY Harbor Recreational Boater Representatives  
Eva Rivlin, NYC Water Trail Association  
Davis Janowski, Manhattan Kayak Company &  
NYC Water Trail Association  
Catie Savage, MCB4  
Carl Darmanin, Reicon  
Marina Balber, ConEd  
Rob Buchanan, NYC Water Trail Association  
Steering Committee & Village Community  
Boathouse  
Maeve Gately, Hudson River Community Sailing  
Richard Day, DSNY  
Andrew Feltes, ConEd  
Tom Adams, HRPT  
Omar Velasquez, DSNY  
Kimberly Williams, ConEd  
Nathan Hauser, Moran Towing  
Leslie Boghosian Murphy, MCB4  
Emily Ruby, Riverkeeper & Hudson River Trail  
Peter Ebright, New York Cruise Lines  
Stephen Lyman, MAPONY  
Shino Tanikawa, NYC Soil and Water Conservation  
District  
Steven Yarczower, Intrepid Museum

NYCEDC  
Giacomo Landi  
Allison Dees  
Jackie Ting  
Tara Das  
Alec Militic

Hatch  
Joshua Nelson  
Tomer Chen  
Spencer Robins

Purpose: Adjacent Facilities to MCT and Other New York Harbor Users - Risk and Hazards  
Workshop for MCT Navigation Safety Risk Assessment

## General Discussion

On October 23, 2025, NYCEDC convened a hazard and risk assessment workshop regarding the Manhattan Cruise Terminal (MCT) Navigation Safety Risk Assessment (NSRA) with representatives from adjacent facilities to MCT and other users of New York Harbor that were not able to be represented in previous stakeholder workshops. Those that attended the meeting in person included representatives from recreational boating groups, City agencies, commercial operators, and environmental organizations. All attendees were in person and no virtual attendance was available. Steven Yarczower, from the Intrepid Museum, and Em Ruby, from Riverkeeper, departed halfway through the meeting and did not participate in the HAZID portion of the workshop. Also in attendance were representatives from NYCEDC and Hatch.

After presenting the overall configuration of the proposed terminal, the participants were asked general questions regarding the NSRA as well as the effect that the proposed terminal will have on navigation in the area of the Hudson River around MCT. Once the workshop was completed, attendees were provided a copy of the questionnaire and were given an opportunity to respond via email. Rob Buchanan provided follow up responses with discussion items and risks.

Below is a compilation of items that were discussed with the originator of the discussion point bolded. Those who did not provide comment during the general discussion session of the workshop were not included in these minutes.

- Maeve Gately:
  - ◆ Inquired as to the exact area to be deauthorized and specifics regarding the NSRA/WRDA process.
  - ◆ Inquired as to whether projected increase in current speed in the center of the channel is being included in the modeling for the NSRA.
- Nathan Hauser:
  - ◆ Commented that Moran Towing has several new larger harbor tugs to accommodate larger ships calling in the harbor, and have desired to build hybrid or electric tugs.
- Rob Buchanan:
  - ◆ Stressed the importance of stakeholder engagement, such as these workshops, and wanted to understand what the timeline is for the NSRA and WRDA. He generally wanted more background to the NSRA and WRDA processes, including who will be evaluating the Proposed Project, timeline for response, the final form of the risk assessment, and if USACE and USCG would have a formal role.
  - ◆ Inquired as to whether the Maritime Security Zone would be extended further into the navigable waterway to accommodate the redeveloped MCT.
  - ◆ Wanted to know if stakeholders would have another chance to comment on the NSRA.
  - ◆ Noted that small and human-powered craft tend to navigate along the pierhead line not only to avoid the larger vessels in the middle of the channel, but also to minimize

the effects of wind and current and to be closer to landings and egress points in the event of an emergency.

- Eva Rivlin:
  - ◆ Inquired as to whether increased ferry, cruise, recreational, and other vessel traffic is being modeled in the NSRA, and whether there would be an increase in the dredging area and number of dredging events.
- Richard Day:
  - ◆ Inquired as to whether there would be an increase in the number of vessels calling at MCT as a result of the Proposed Project.
- Peter Ebright:
  - ◆ Commented that anything that brings more tourists and more vessel traffic to the New York would be good for business.
  - ◆ He noted that NYCL's main concern is that dredging at MCT would cause silt and dredge spoils to migrate to their piers further south.
- Leslie Boghosian Murphy:
  - ◆ Noted that Community Board 4 (CB4) and NYCEDC have been in discussions for years regarding MCT and that some of the main aspects that CB4 is looking for in the redeveloped MCT, including park space, public accessibility, and need for shore power.

## Questions

After discussions regarding the NSRA and the proposed redevelopment plan, the group transitioned into the hazard and risk identification portion of the workshop. This included a list of questions as shown below, organized into sections, for the attendees to answer.

Answers were written by attendees on notecards, which were later collected and have been compiled below. Attendees generally provided answers related to the overall topics in the various sections. Where specific questions were or weren't answered, they have been called out below. Steven Yarczower, from the Intrepid Museum, and Em Ruby, from Riverkeeper, departed halfway through the meeting and did not participate in the HAZID portion of the workshop. Names of specific people or organizations that did not comment on specific questions were omitted from these minutes.

### 1. Current Usage and Operations Around MCT

1.1. What is your name and what organization do you represent?

- See above

1.2. What type of activities does your organization/do your users engage in on the Hudson River?

- **ConEd** operates a steam generating plant at Pier 98. They use the pier for natural gas fuel oil deliveries in the winter. ConEd also provides power to MCT and occasionally perform transformer transports via Pier 84, 87, and 88. They also operate a substation at W. 49<sup>th</sup> St.

- **DSNY** have barge deliveries from their paper recycling facility on Pier 99 to their facility in Staten Island.
- **Moran** operates tugs and barges on the Hudson River, and provide harbor assist tugs for cruise ships calling at MCT.
- **Hudson River Park Trust** control boathouses to Pier 84 to the south and Pier 96 to the north. Their tenant, Circle Line, operates out of Pier 81 and Pier 83, and NYC Ferry operators out of their Pier 79.
- **Hudson River Community Sailing** operate daily from May through November transiting out of Pier 66 in 4-5-person, 26-foot keel boats.
- **Village Community Boathouse** rows out of 27-foot-long longboats.
- **Reicon** engages in construction activities around MCT (currently at Pier 94), and their parent company (Reinauer) has tugs and barges regularly transiting by MCT.
- **Manhattan Kayak Company** operates daily paddle board and kayaking trips through the spring and summer and over the weekends during the winter. From May 1 to Nov 1, run guided beginner kayak trips daily, from morning to night at slack current (weather permitting). 70 private kayaks, canoes, and paddleboards are stored year-round by independent paddlers who use the river 24/7/365 from Pier 84.
- **NYC Water Trail** paddlers transit by MCT year-round at all times of day in guided groups or as solo paddlers.

1.3. How frequently does your organization/do your users transit in the area of the Hudson River near MCT?

- **ConEd** noted that they had about three barge deliveries of oil in 2024. In a worst case scenario, they expect about five oil barge deliveries in a winter. Transformer transports may happen once or twice per year.
- **DSNY** noted that barges call four to five times per, typically transit between Pier 99 and Staten Island during a window of 3:00am and 3:00pm.
- **HRPT** has users constantly transiting near MCT.
- **Hudson River Community Sailing** sailors transit past MCT on a daily basis.
- **Village Community Boathouse** boaters operate weekly during the main season.
- **Reicon** vessels transit the area around MCT daily/weekly.
- **Manhattan Kayak Company** trips all launch and land at Pier 84, immediately south of the Terminal, and travel north alongside it before returning south along the same route.
- **NYC Water Trail** boaters typically have highest traffic on weekends between May and November.

1.4. Do your users launch or land near MCT?

- **ConEd** uses the Pier 98 for barges mooring there transiting from south to north.
- **DSNY** uses Pier 99 for barges mooring there transiting from south to north.
- **HRPT** has boathouses at Pier 84 and Pier 96 where recreational boaters launch from.

- **Hudson River Community Sailing** sailors launch from Pier 66, with 15 small boats at this location.
- **Village Community Boathouse & NYC Water Trail** boaters occasionally launch from Pier 84 and 86.
- **Manhattan Kayak Company** boaters launch out of Pier 84. The Pier 84 public launch, owned by the Hudson River Park Trust, is open for general use under MKC on-site management. MKC does not provide route guidance or assume responsibility for independent paddlers, who vary widely in skill and local knowledge. Public use is frequent as the Hudson grows in popularity for recreation.
- **NYC Water Trail** boaters launch out of Pier 84 and 96, with programs for novice and expert paddlers out of both locations. There are other launch sites around Manhattan that have guided trips past MCT in both directions.

1.5. How do your users/captains typically operate when encountering large vessels, like cruise ships?

- **Eva Rivlin** noted that typically, recreational boaters have to wait for traffic, which can be difficult depending on current and tide conditions.
- **DSNY** noted that their tug and barge operators navigate around other vessels.
- **ConEd** noted that their tug and barge operators navigate around other vessels.
- **Maeve Gately** noted that sailors stay well clear of cruise ship traffic.
- **Rob Buchanan** noted that boaters attempt to contact cruise ships via VHF Channel 13 to coordinate passing.
- **Reicon** vessels are AIS-monitored and operate as required by USCG.
- **Manhattan Kayak Company** boaters communicate to other vessels via VHF radio when transiting the area.
- **Eva Rivlin** noted that human powered boaters will always defer to larger motorized vessels and never presume right of way. Boaters generally use VHF radios, monitoring and communicating on channel 13, and larger vessels will often communicate location of human powered boaters.

1.6. Are there any specific waterside navigational challenges your users/captains currently face in this section of the river?

- **Eva Rivlin** expressed concern about the vessel traffic that services the cruise ships, rather than the cruise ships themselves. In particular, she noted that tugs transiting in and out of the MCT basin are typically less communicative, and that ferry traffic is especially bad at communication.
- **Nathan Hauser** the current challenge for Moran's tug and barge operators is limited working space for tugs berthing cruise ships at MCT.
- **Omar Velazquez** suggested that there aren't specific waterside traffic concerns for his operators.

- **Maeve Gately** noted that sailors have had a more difficult time with managing clearance with larger ships due to the HRGS project causing further congestion of vessel traffic south of MCT. Generally, cruise ships are able to stay out of the way.
- **Rob Buchanan** indicated that the uncertainty of cruise ships departure times poses a challenge for how much time paddlers have to transit past MCT as it can be difficult to hold position against the current. He also noted the challenge of rowing farther out into the channel as a result of the MSZ. Can be difficult for human powered boaters to communicate via radio as they are often using both hands to paddle.
- **Catie Savage** noted that boaters coming from Pier 96 heading south frequently cross to the New Jersey side of the river to avoid vessel traffic at the cruise terminal. She also noted that ferry traffic is the biggest concern as they move very quickly.
- **Davis Janowski** noted that the main challenge he and other boaters have is communicating with ferries and NYPD, as they are generally unresponsive on VHF radio, but boaters typically have good relationship with passenger vessels and USCG. He also noted that marine radios have less power to transmit communication. The other current challenge for them is the HRGS project.
- **Eva Rivlin** noted that visibility around MCT is already restricted and tug/barge traffic out of the terminal is unpredictable.

## 2. Impact of MCT Redevelopment

2.1. How would the proposed MCT redevelopment project, as outlined in the presentation, to affect your operations?

- **Andrew Feltes** did not expect the Proposed Project to affect operations.
- **Nathan Hauser** indicated that the Proposed Project would provide more room for tugs to assist cruise ship berthing and approaches at MCT.
- **Omar Velazquez** indicated that increased traffic in the waterways could cause delays to barge transport and increase possibility of accidents.
- **Tom Adams** hoped that the additional footprint of the Proposed Project would increase safety and connectivity between parks to the north and south.
- **Maeve Gately** expressed concern regarding increased traffic in a narrower area of the river as a result of the Proposed Project, blind spots around the extended piers, and the Maritime Security Zone being extended around the proposed redeveloped piers.
- **Richard Day** noted that there is the potential for traffic issues with DSNY barges if vessel traffic patterns and timing changes.
- **Rob Buchanan** noted that the Proposed Project adds hazards, both fixed objects and vessels, to the boaters' path. The project will force boaters to move further out into the navigable channel to account for the extended structure and the MSZ. The extended piers will also cause a potential visibility issue up and down stream.
- **Marina Balber** indicated that the Proposed Project will likely require an increase in local power demand in the future.

- **Kimberly Williams** indicated no foreseeable impact as a property owner or current services.
- **Carl Darmanin** does not expect the Proposed Project to affect their operations.
- **Davis Janowski** noted that boaters will potentially have to transit further out into the main channel or go north during construction periods. He also commented that there will be a likely increase in recreational boater traffic.
- **Eva Rivlin** expressed concern that increased traffic, decreased visibility due to line of sight infringement, and less navigable space in way of the redeveloped MCT will potentially increase risk of collisions with other vessels. She also indicated that human powered boaters being pushed further into the main channel will reduce their ability to keep clear of larger commercial vessels.

2.2. How do you foresee the proposed redevelopment project impacting the safety or flow of traffic in this part of the river, particularly during high-traffic periods?

- **Omar Velasquez** expressed concern regarding increase of ferry traffic as a result of constriction of the channel and that there is the potential for increased risk of collisions with other vessels.
- **Catie Savage** expressed concern regarding increase of ferry traffic as a result of constriction of the channel.
- **Nathan Hauser** commented that the Proposed Project would likely not have a significant impact on commercial vessel traffic.
- **Andrew Feltes** expects little to no impact to their operations as a result of the Proposed Project.
- **Maeve Gately** noted that their main concerns are related to ferries and changing patterns of tugs and barges. She also expressed concern over the potential that cruise ships may have to begin their approaches to the terminal further south.
- **Richard Day** expressed concern over potential increase in collisions and delays.
- **Rob Buchanan** noted that there would probably be increased number of scenarios where boaters would have to hold position to accommodate cruise ship traffic, which will be more difficult potentially because of increased current in the center of the river.
- **Kimberly Williams** indicated that there may be increased vessel traffic as a result of the narrowing of the channel, and noted possible concerns for smaller boats.
- **Carl Darmanin** indicated that the proposed redevelopment should have little impact, noting that there are areas of the Hudson River further south of MCT that are significantly narrower where a large amount of vessel traffic transits.
- **Davis Janowski** noted that boaters will potentially have to transit further out into the main channel or go north after construction of the Proposed Project is completed, and their operations may be further affected depending on enforcement of the Maritime Security Zone.

### 3. Environmental or Other Operational Hazards

- 3.1. What risks associated with weather, current, tidal range, wind, visibility, ice, etc. might you expect with the proposed redevelopment?
- **Omar Velazquez** suggested that large boats and barges will likely not be affected based on the data presented.
  - **Andrew Feltes** expects little to no risks as a result of the Proposed Project.
  - **Eva Rivlin** noted that understanding that the impacts the extended pier structures will have on the currents is important factor for vessel traffic in the area.
- 3.2. What type of challenges associated with communication with vessel traffic do you anticipate?
- **Omar Velazquez** suggested that communication with ferry traffic will continue being an issue.
  - **Andrew Feltes** expects little to no risks as a result of the Proposed Project.
- 3.3. What type of vessel or terminal security risks do you foresee?
- **Andrew Feltes** expects little to no risks as a result of the Proposed Project.
- 4. Mitigation Measures**
- 4.1. Do you have any recommendations that could reduce potential risks associated with the MCT redevelopment?
- **Omar Velazquez** suggested not to include a ferry landing at the terminal.
  - **Catie Savage** suggested improving communication between ferries and boaters.
  - **Rob Buchanan** suggested that a safety boat or water traffic controller specifically looking out for the interests of recreational boaters would reduce risks, particularly during cruise ship arrivals or departures. He also suggested increasing education about the harbor, including staffing and programming of new public boathouses and waterfront education centers around the harbor. He suggested devising a monitoring and communication system with a couple of levels of redundancy: regular radio calls on channel 13 that take place at, say, 30, 15, 10 and 5 minutes before cruise ship landings and departures, for example, or a red/green hold up/proceed flag system could be deployed and possibly echoed with a similar flag or light system atop the outermost dolphins.
  - **Davis Janowski** suggested installing a current meter, camera, temperature gauge, and/or wind monitor at the end of the piers or on buoys near the piers. He also suggested installing an intermediary that promotes vessel safety.
  - **Nathan Hauser** suggested that recreational users use websites and apps that track AIS movements of vessels to assist with vessel coordination. He also suggested introducing a safety boat that would interface between tugs, ferries, and recreational traffic.
  - **Eva Rivlin** suggested creating a dialogue between all stakeholders and USCG.
  - **Maeve Gately** suggested instituting an education campaign in anticipation of changing traffic patterns, including boating safety alerts and educating boaters about currents, and following up with vessels that violate traffic pattern rules. **Stephen Lyman** noted that MAPONY has an educational subcommittee that would be able to address these issues.

4.2. Is there anything else we should consider in the Navigational Safety Risk Assessment?

- **Davis Janowski** suggested taking into account the Billion Oyster Project and potentially integrating that into the Proposed Project, noting that dredging may affect the oysters.
- **Shino Tanikawa** suggested that the Proposed Project include an additional environmental impact assessment aside from the typical EIS.

## Risks

The risks and hazards that were identified during the workshop have been compiled in the table below, with their respective mitigation measures as applicable.

**Table B-6: Recreational Vessel Operator HAZID Risk Register**

Risk ID	Originator	Risk Description	Potential Mitigation Measures
1	Rob Buchanan	Longer piers would block sightlines, especially after dark or during sunset glare. Paddlers use white lights, but other vessels may not see them in time. Many vessels are not monitoring VHF, and even when they are, large steel cruise ships can block line-of-sight radio signals between boats on opposite sides. A past ferry/kayak collision off Pier 76 showed how sun glare and missed radio communication can combine to cause serious accidents.	Using a red/green hold up/proceed flag system could be deployed and possibly echoed with a similar flag or light system atop the outermost dolphins.
2	Rob Buchanan	New structures extending far into the river would alter the tidal flow, forcing currents to accelerate around them and creating suction zones. This, combined with turbulent eddies, can capsize, trap, or crush paddlers against structures.	It is suggested that a hydrodynamic analysis of the pier extensions with a cruise ship at berth be conducted in the future.
3	Rob Buchanan	The risk of a new construction that extend out into the channel is the need to venture significantly further out towards the middle of the river to pass by. That puts them closer to those larger vessels, exposes them to more wind and current, and leaves them farther from potential egress points.	Deploying a safety boat or water traffic controller specifically looking out for the interests of recreational boaters would reduce risks, particularly during cruise ship arrivals or departures.
4	Rob Buchanan	The terminal is located at a bend in the river, and for small and human-powered boats moving north or south along the pierhead line, the cruise ships would potentially block the view of whatever vessel or vessels might be headed in the opposite direction.	Devising of a monitoring and communication system with a couple of levels of redundancy: regular radio calls on channel 13 that take place at, say, 30, 15, 10 and 5 minutes before cruise ship landings and departures, for example.
5	DSNY	Communication between cruise ships and other vessel traffic is a constant risk for collision and vessel delays in the harbor and around MCT.	Increase dialogue between all stakeholders within the harbor, and implement a standard operating procedure for communication while transiting by MCT to inform all users of vessel traffic movements.



# **Appendix C: Existing 2023 Vessel Traffic Line Plots**

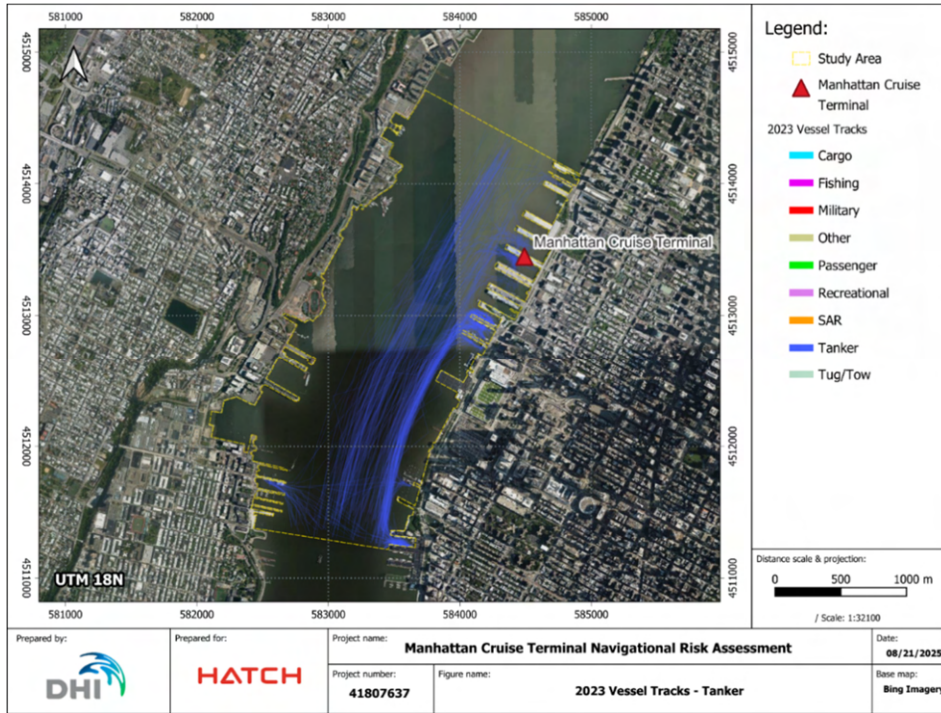


Figure C-1: 2023 Tanker Vessel Tracks Inside Study Area

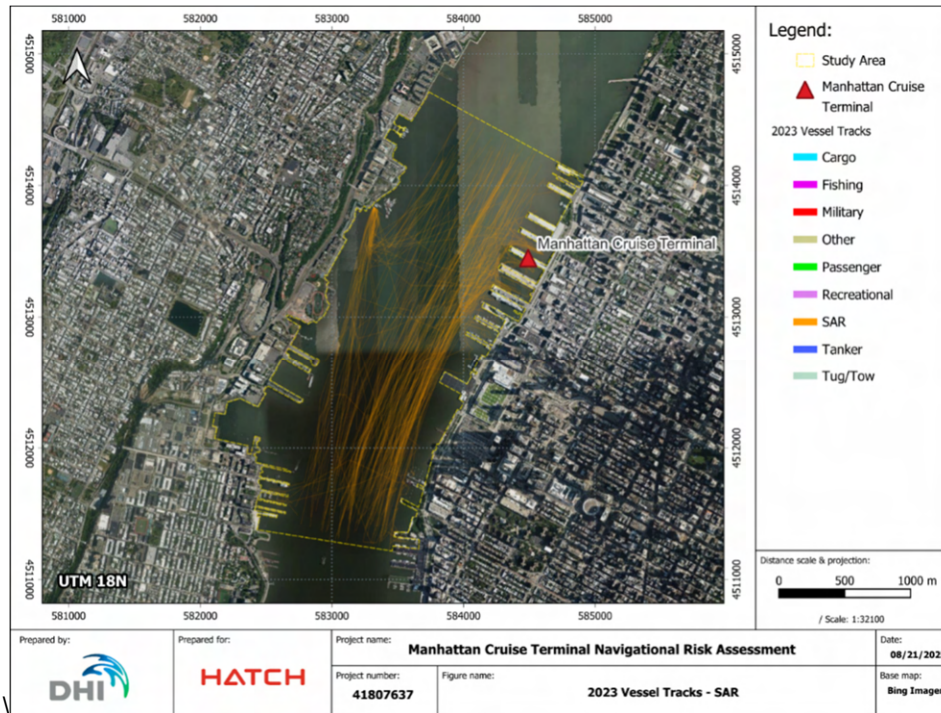
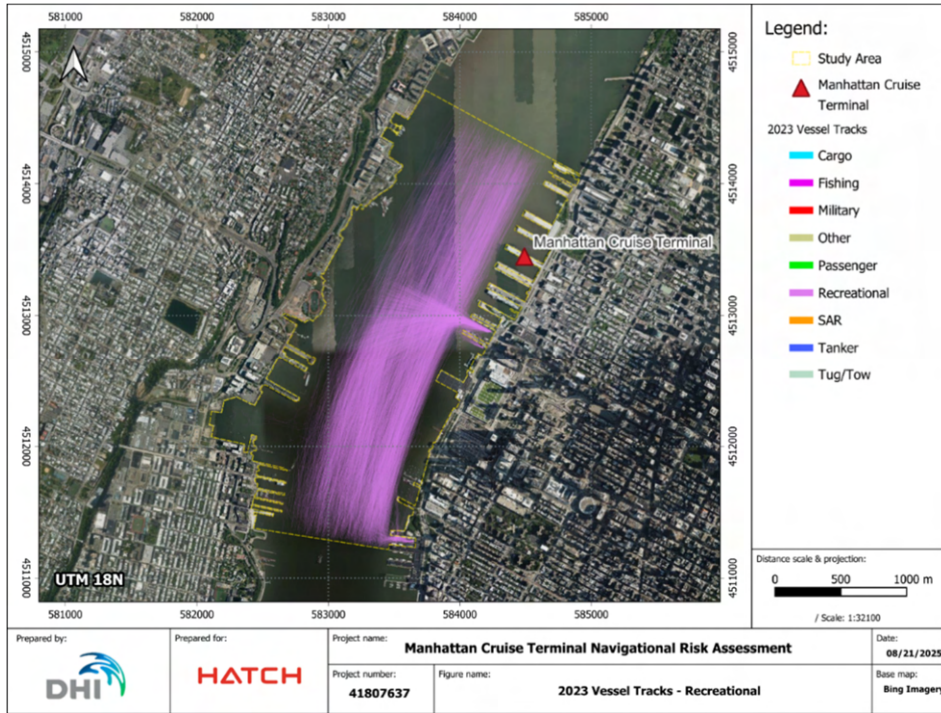
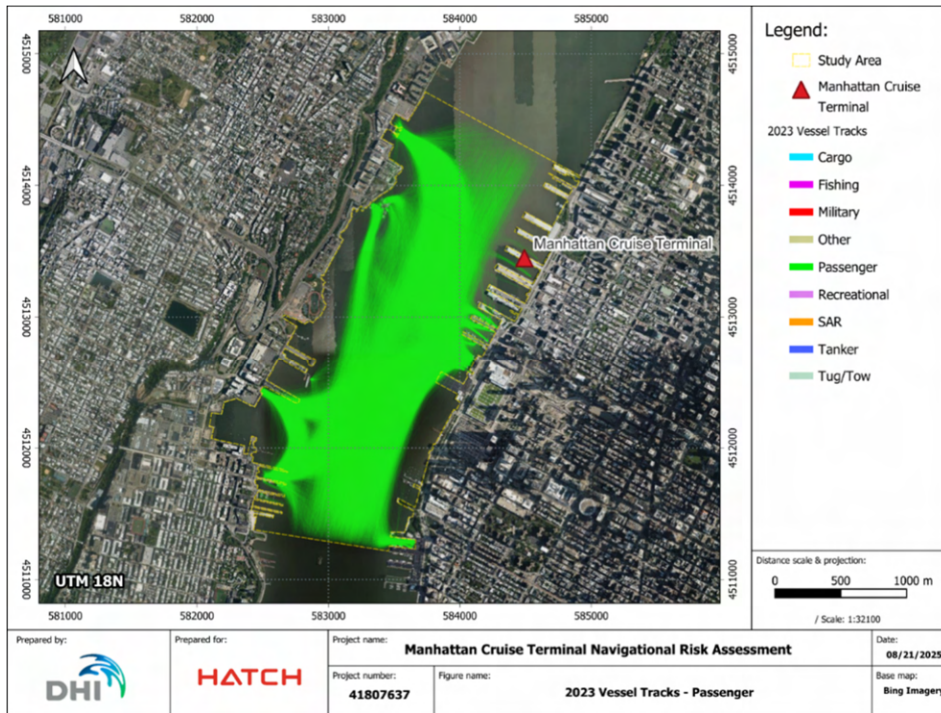


Figure C-2: 2023 SAR Vessel Tracks Inside Study Area



**Figure C-3: 2023 Recreational Vessel Tracks Inside Study Area**



**Figure C-4: 2023 Passenger Vessel Tracks Inside Study Area**

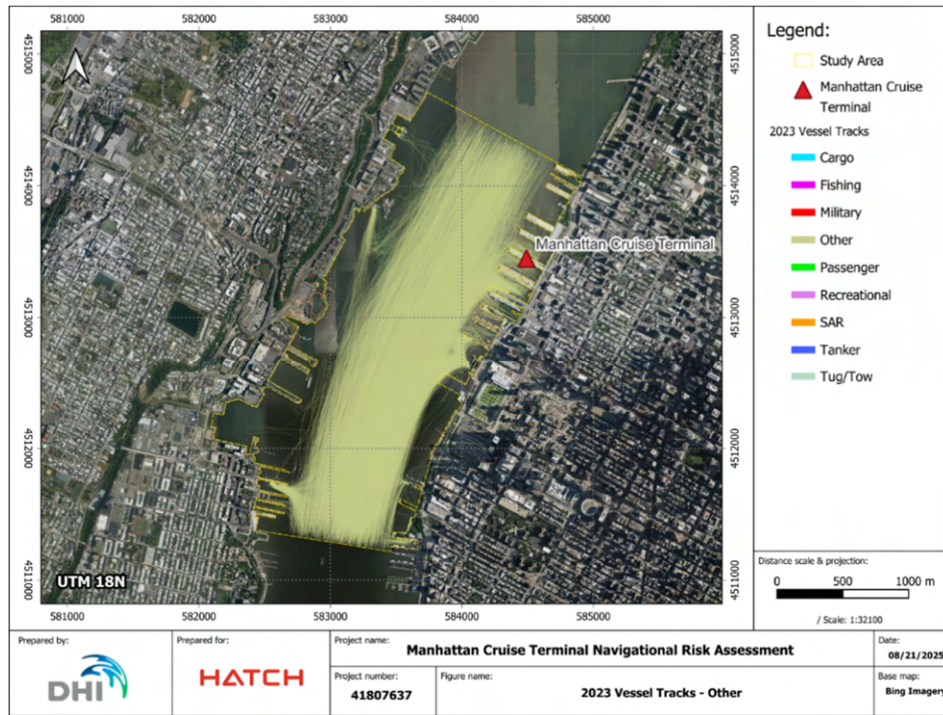


Figure C-5: 2023 Other Vessel Tracks Inside Study Area

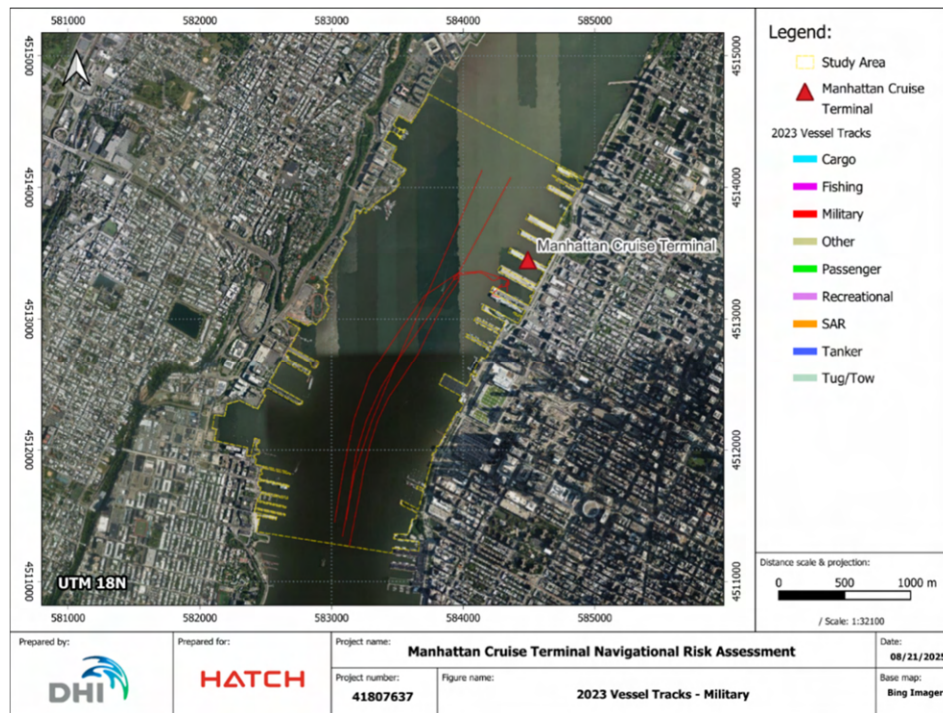


Figure C-6: 2023 Military Vessel Tracks Inside Study Area

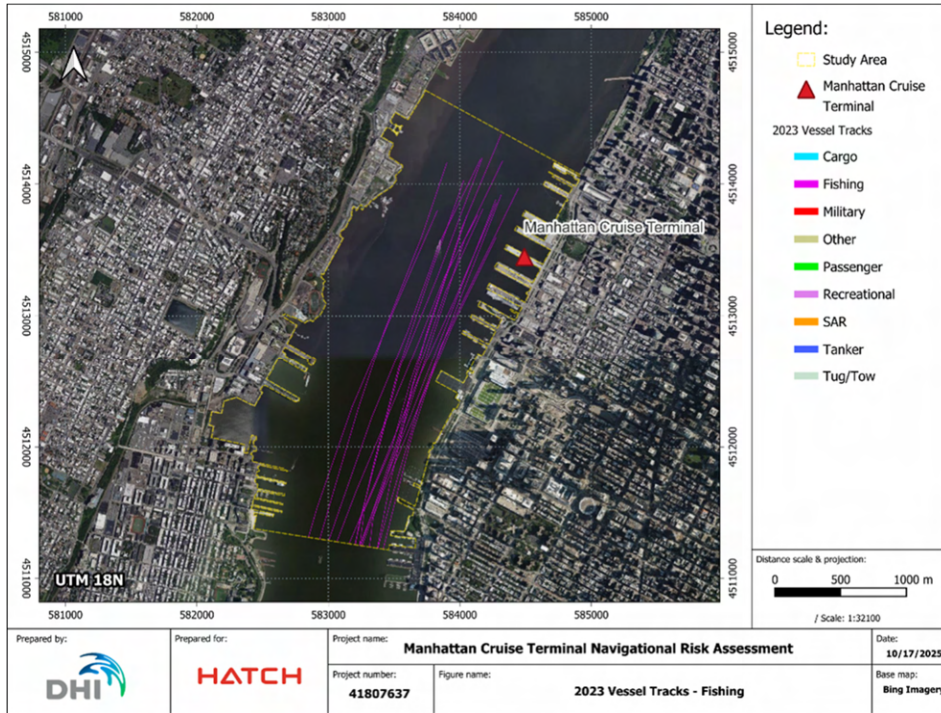


Figure C-7: 2023 Fishing Vessel Tracks Inside Study Area

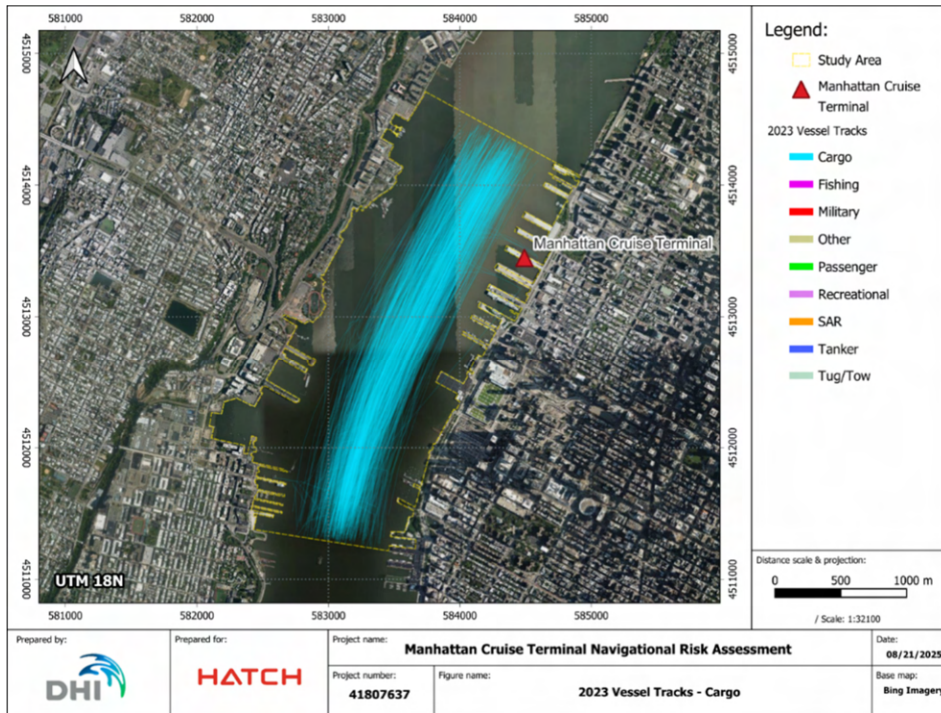
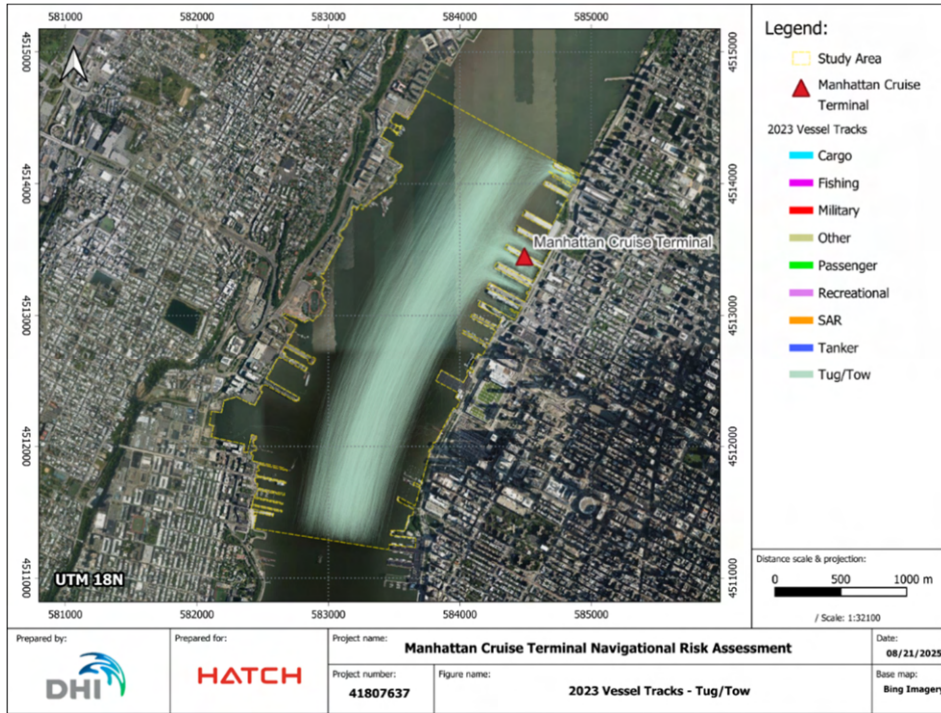
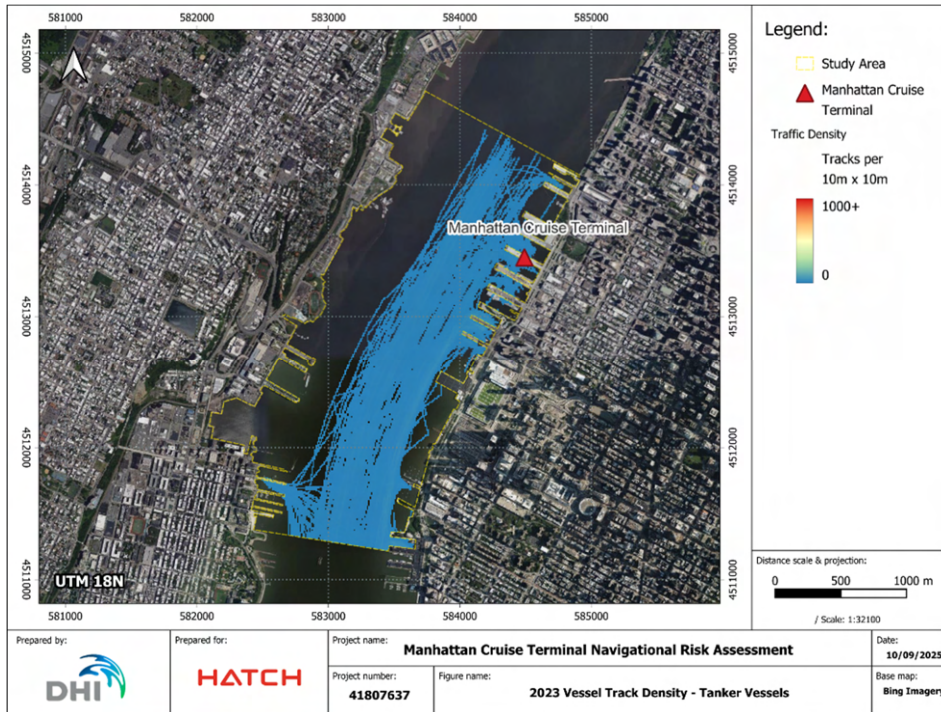


Figure C-8: 2023 Cargo Vessel Tracks Inside Study Area

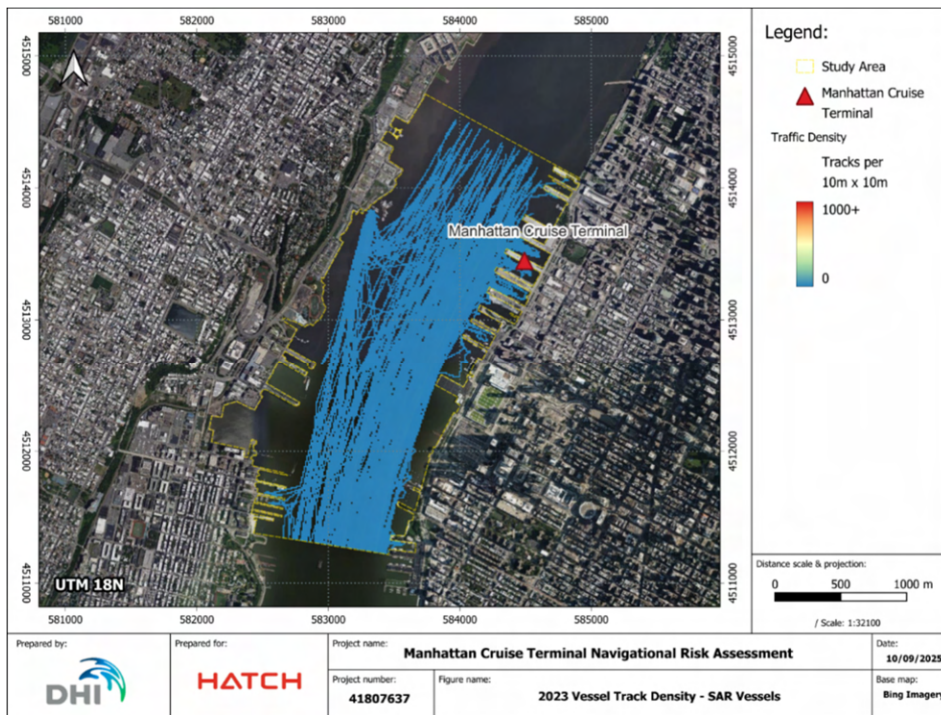


**Figure C-9: 2023 Tug/Tow Vessel Tracks Inside Study Area**

# **Appendix D: Existing 2023 Vessel Traffic Density Maps**



**Figure D-1: 2023 Tanker Vessel Track Density in Study Area**



**Figure D-2: 2023 SAR Vessel Track Density in Study Area**

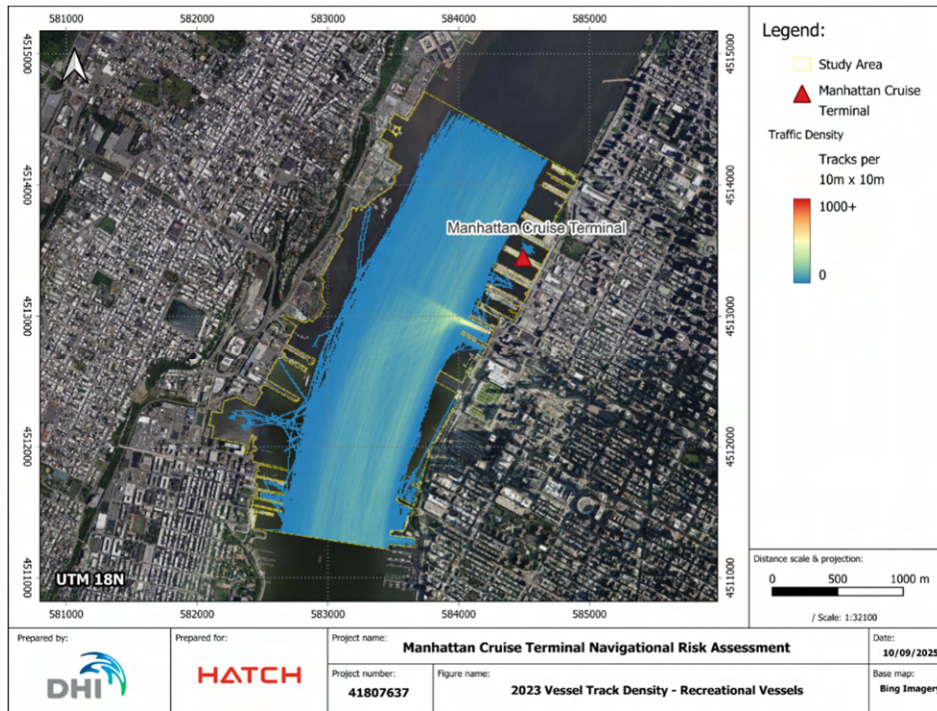


Figure D-3: 2023 Recreational Vessel Track Density in Study Area

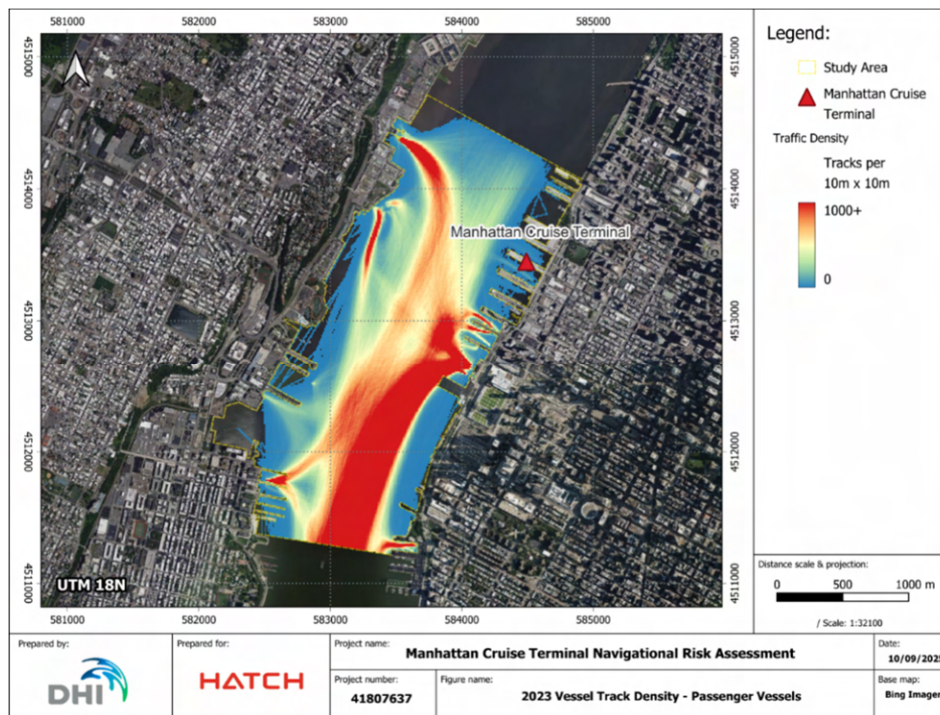


Figure D-4: 2023 Passenger Vessel Track Density in Study Area

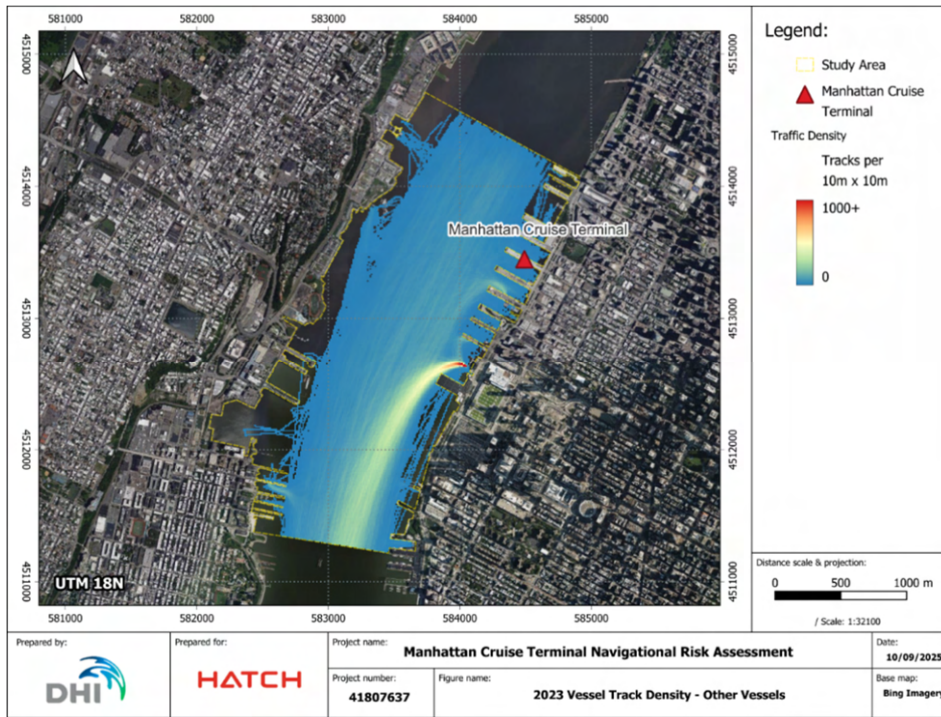


Figure D-5: 2023 Other Vessel Track Density in Study Area

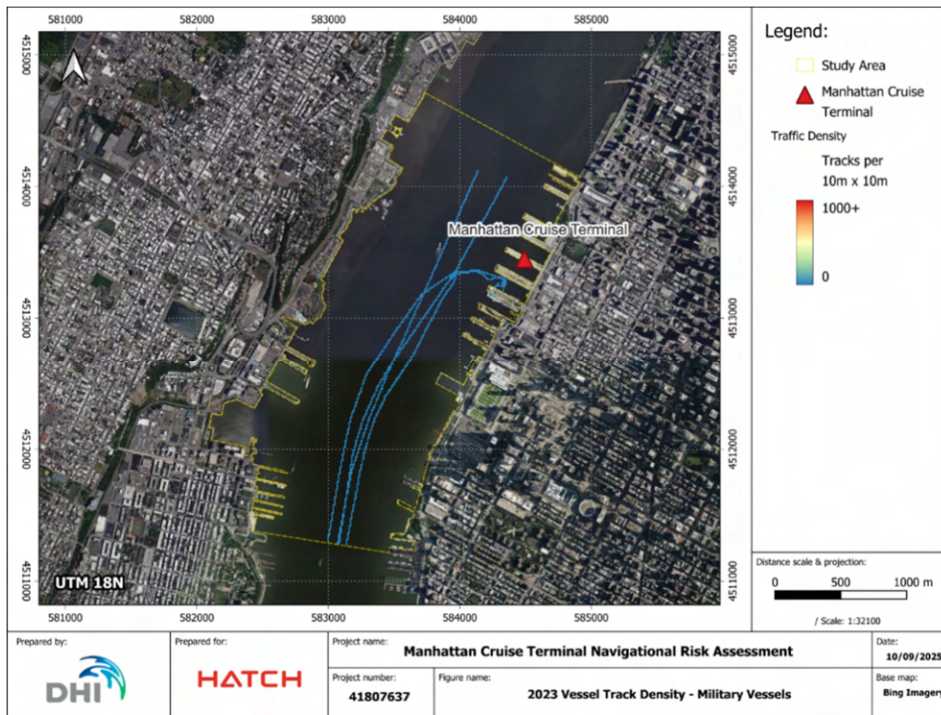


Figure D-6: 2023 Military Vessel Track Density in Study Area

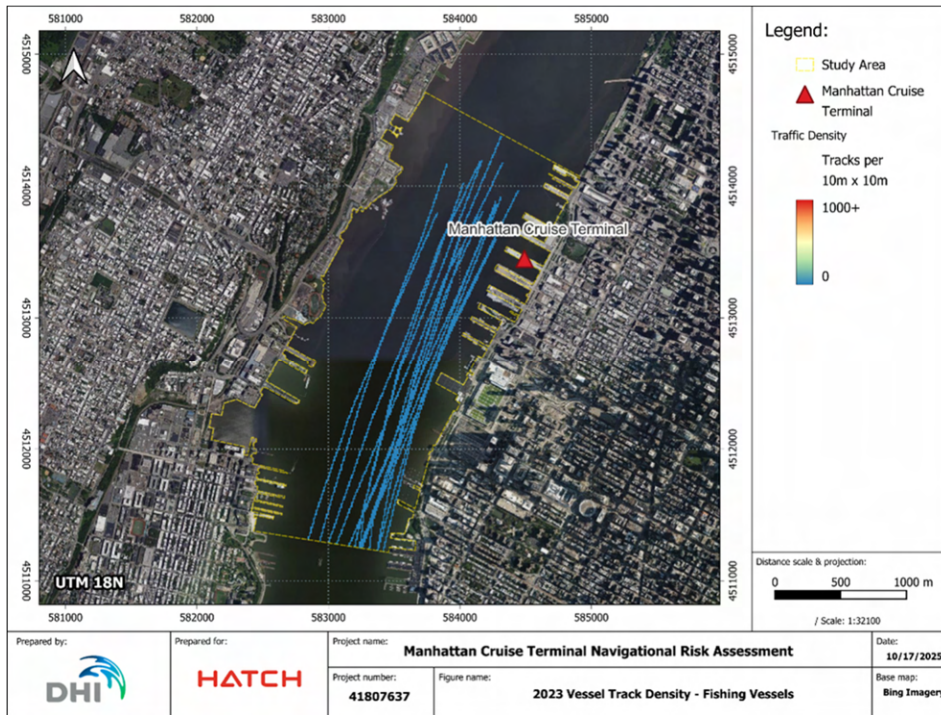


Figure D-7: 2023 Fishing Vessel Track Density in Study Area

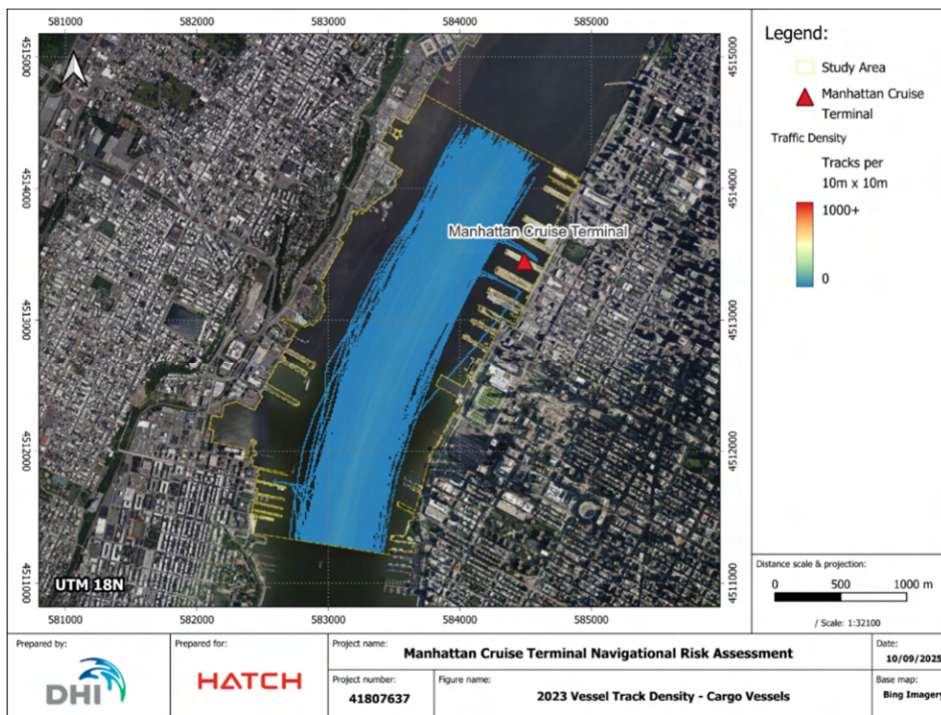
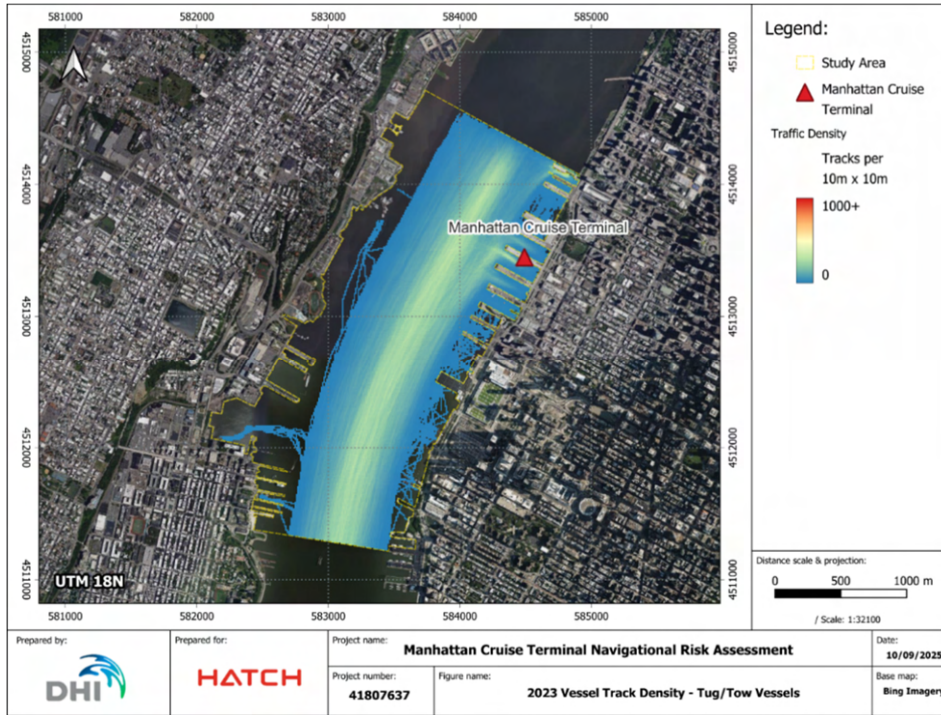
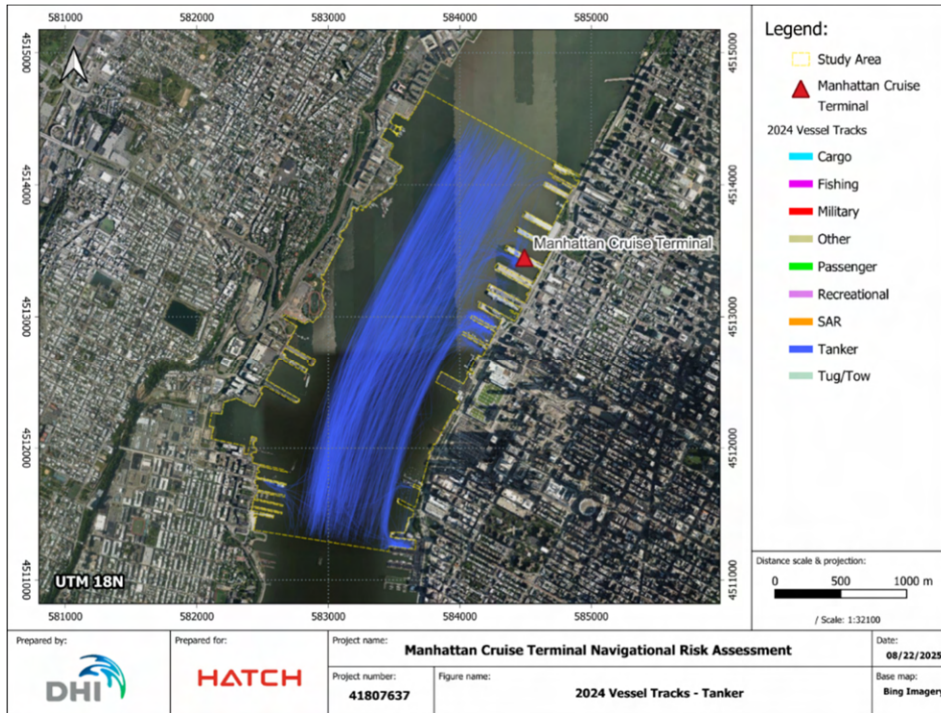


Figure D-8: 2023 Cargo Vessel Track Density in Study Area

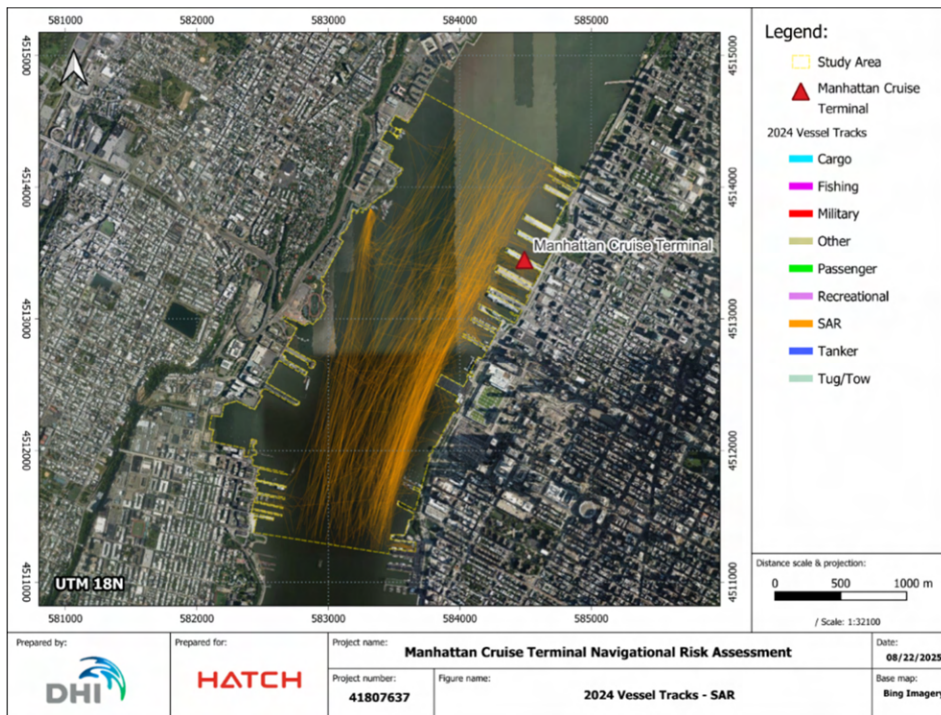


**Figure D-9: 2023 Tug/Tow Vessel Track Density in Study Area**

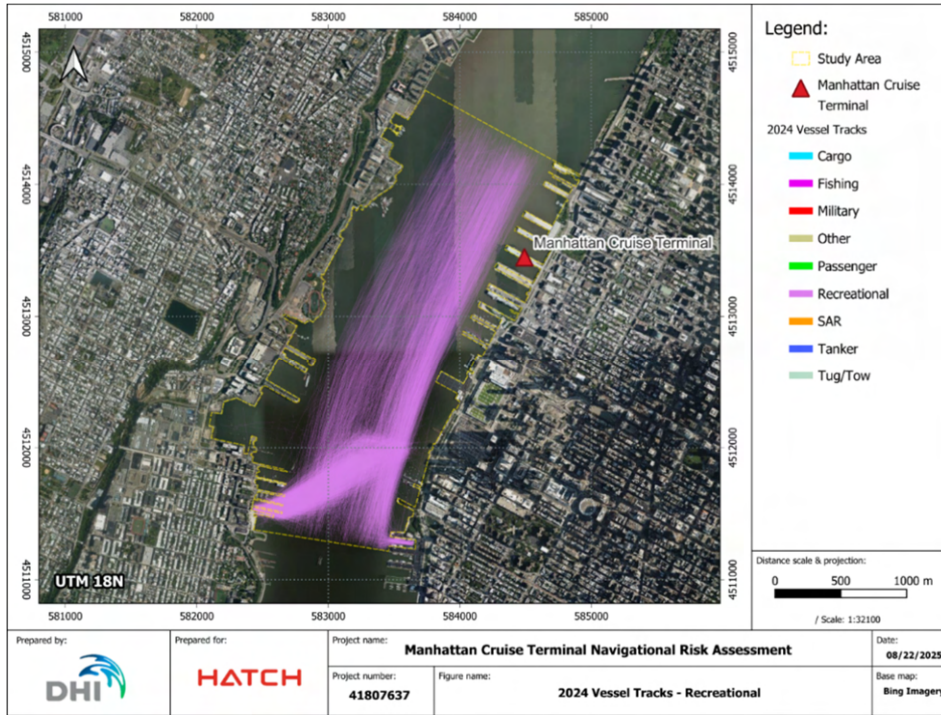
# **Appendix E: Existing 2024 Vessel Traffic Line Plots**



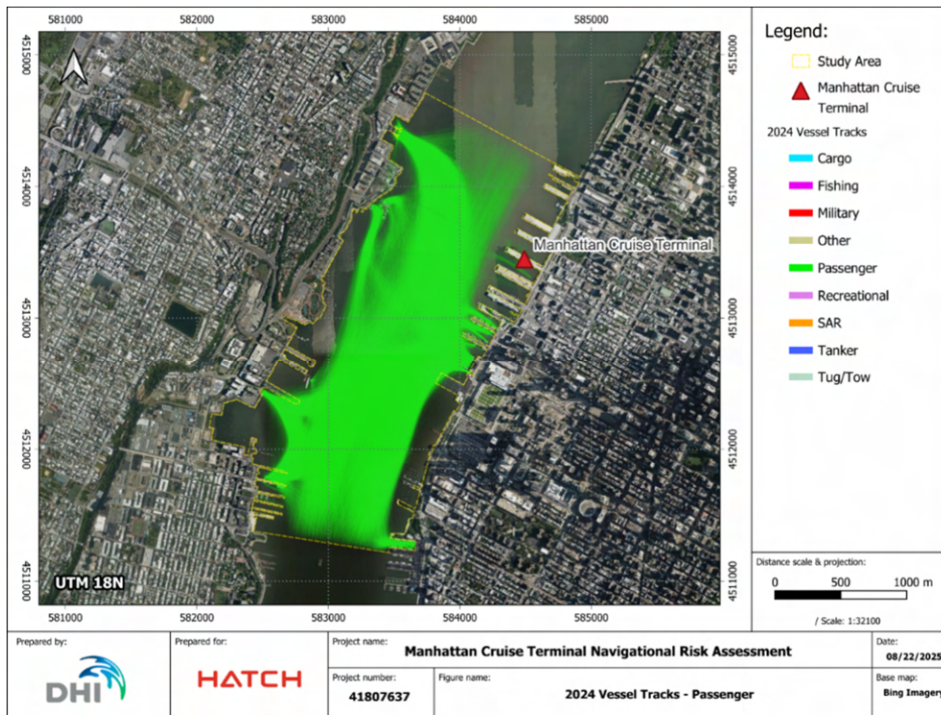
**Figure E-1: 2024 Tanker Vessel Tracks Inside Study Area**



**Figure E-2: 2024 SAR Vessel Tracks Inside Study Area**



**Figure E-3: 2024 Recreational Vessel Tracks Inside Study Area**



**Figure E-4: 2024 Passenger Vessel Tracks Inside Study Area**

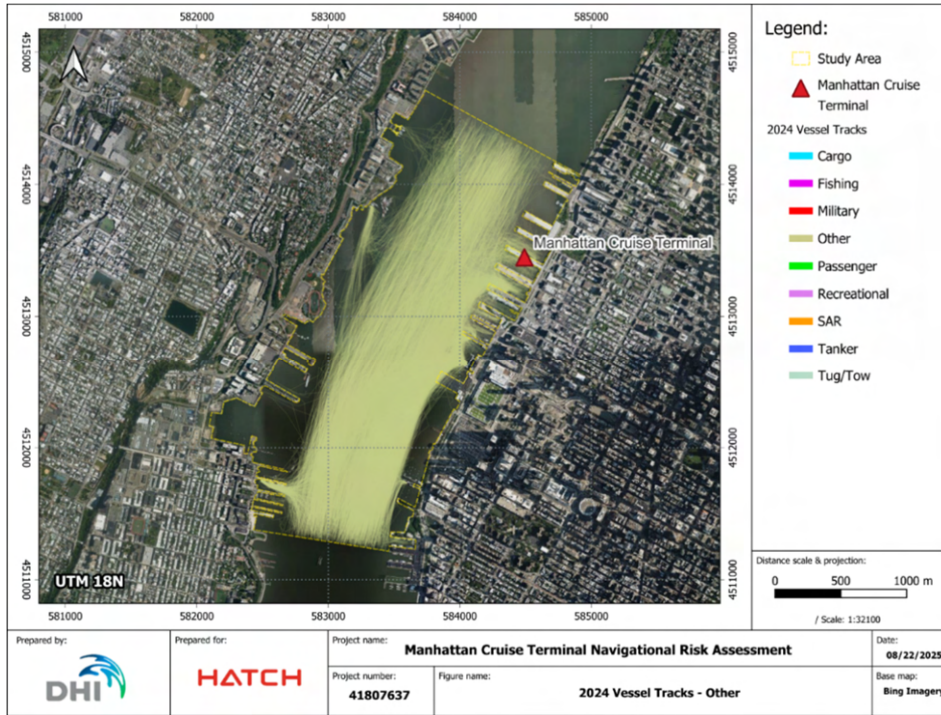


Figure E-5: 2024 Other Vessel Tracks Inside Study Area

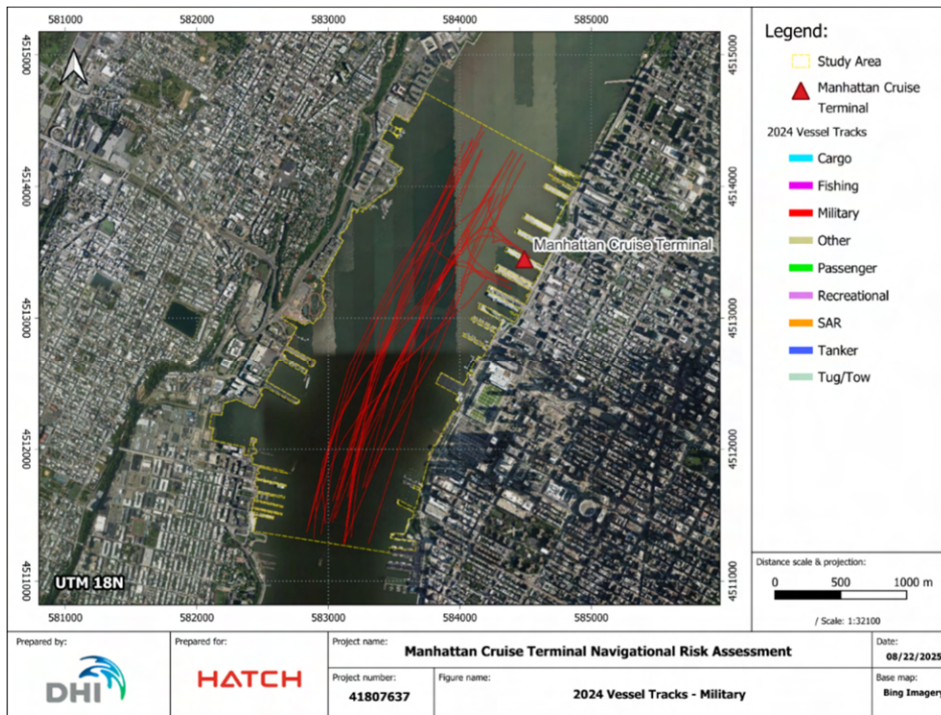


Figure E-6: 2024 Military Vessel Tracks Inside Study Area

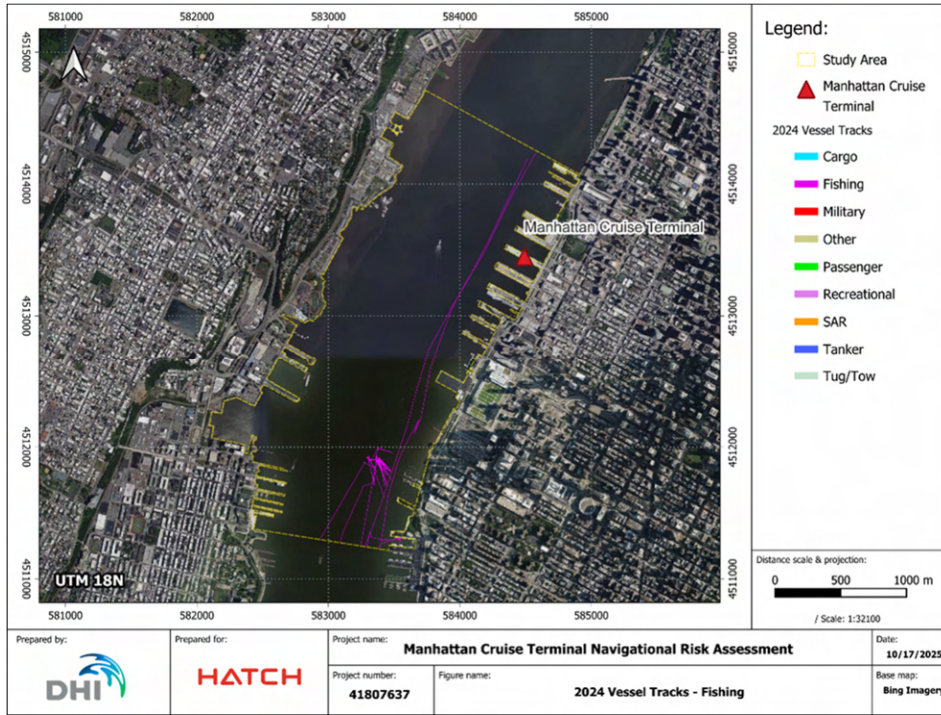


Figure E-7: 2024 Fishing Vessel Tracks Inside Study Area

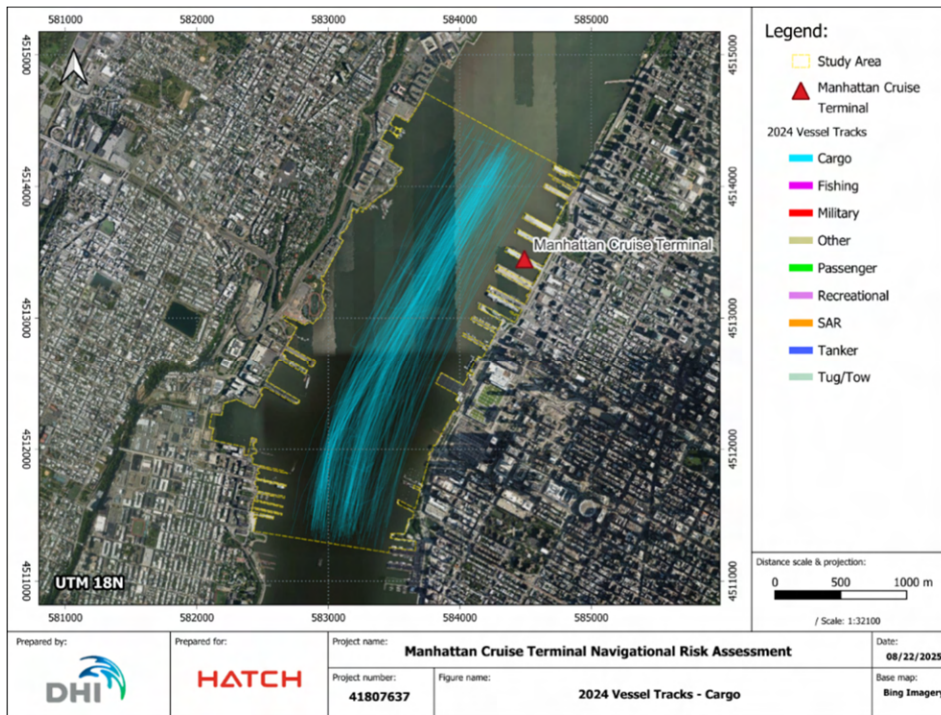
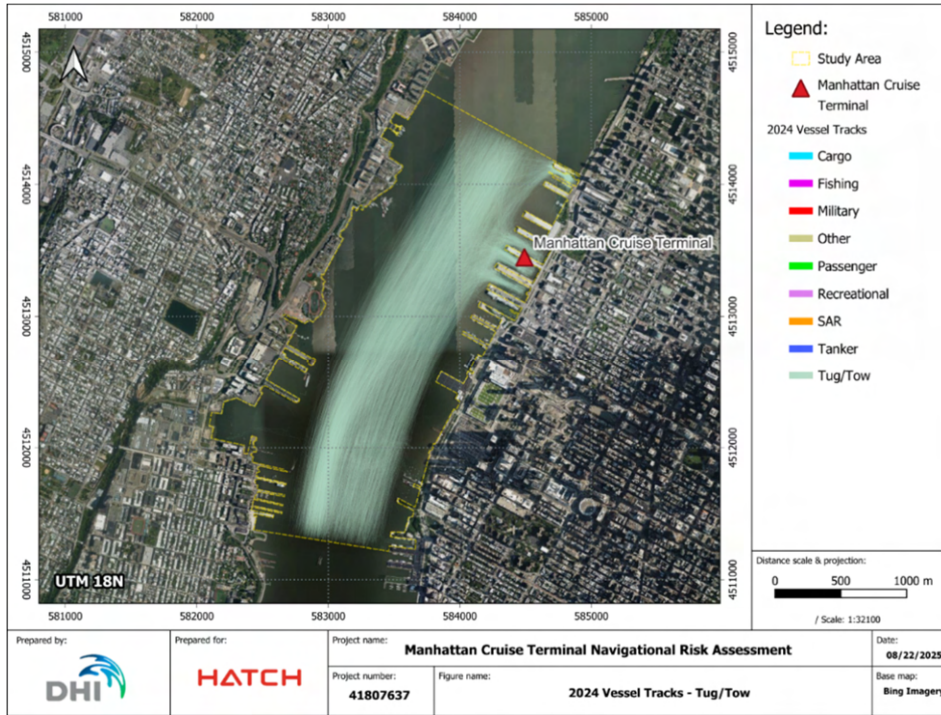
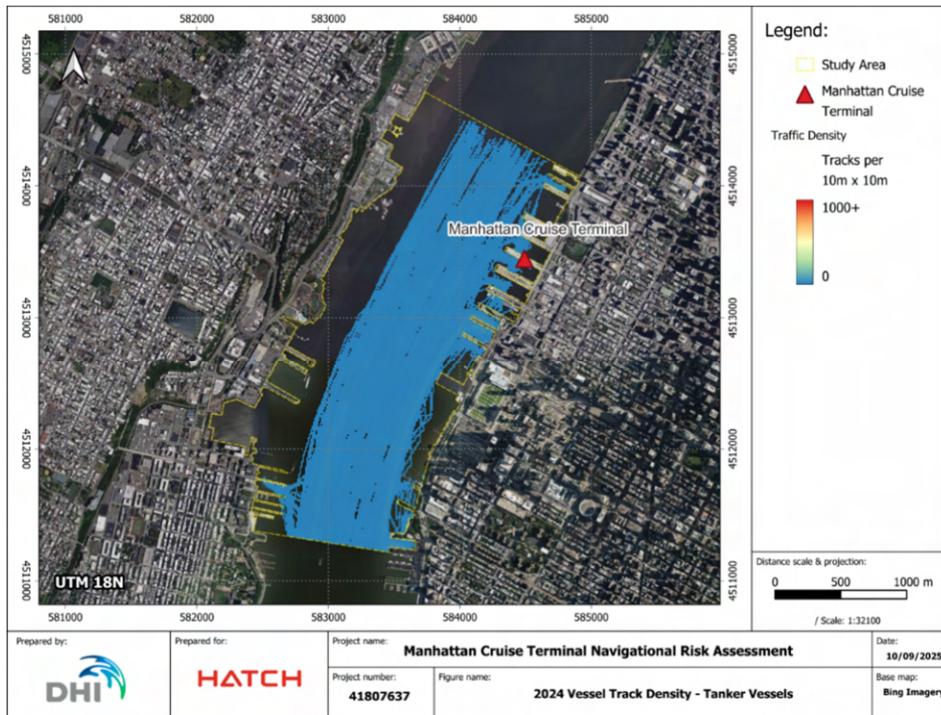


Figure E-8: 2024 Cargo Vessel Tracks Inside Study Area

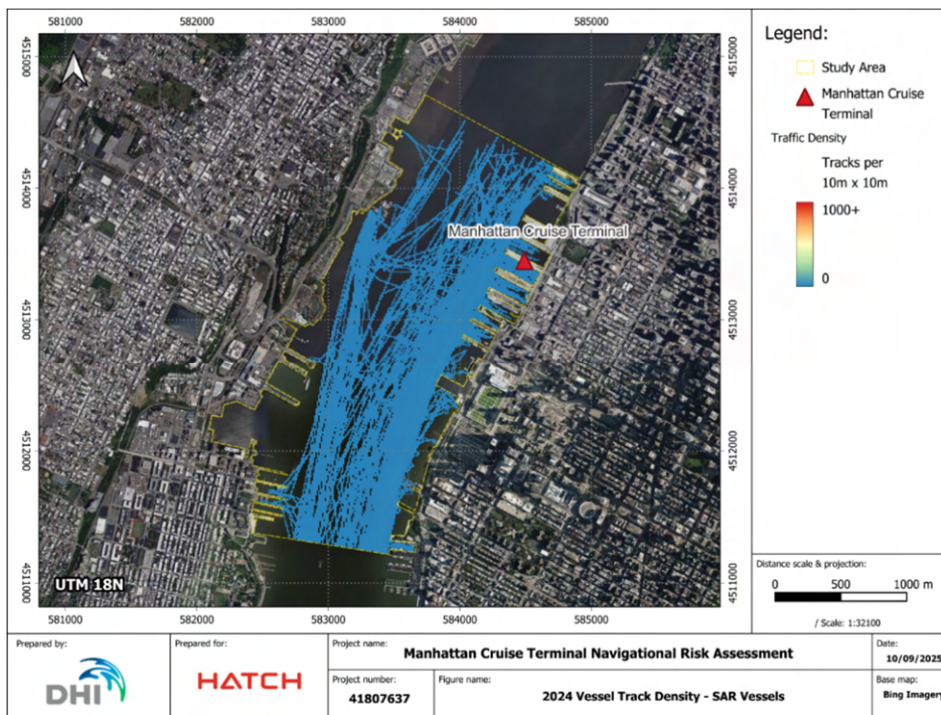


**Figure E-9: 2024 Tug/Tow Vessel Tracks Inside Study Area**

# **Appendix F: Existing 2024 Vessel Traffic Density Maps**



**Figure F-1: 2024 Tanker Vessel Track Density in Study Area**



**Figure F-2: 2024 SAR Vessel Track Density in Study Area**

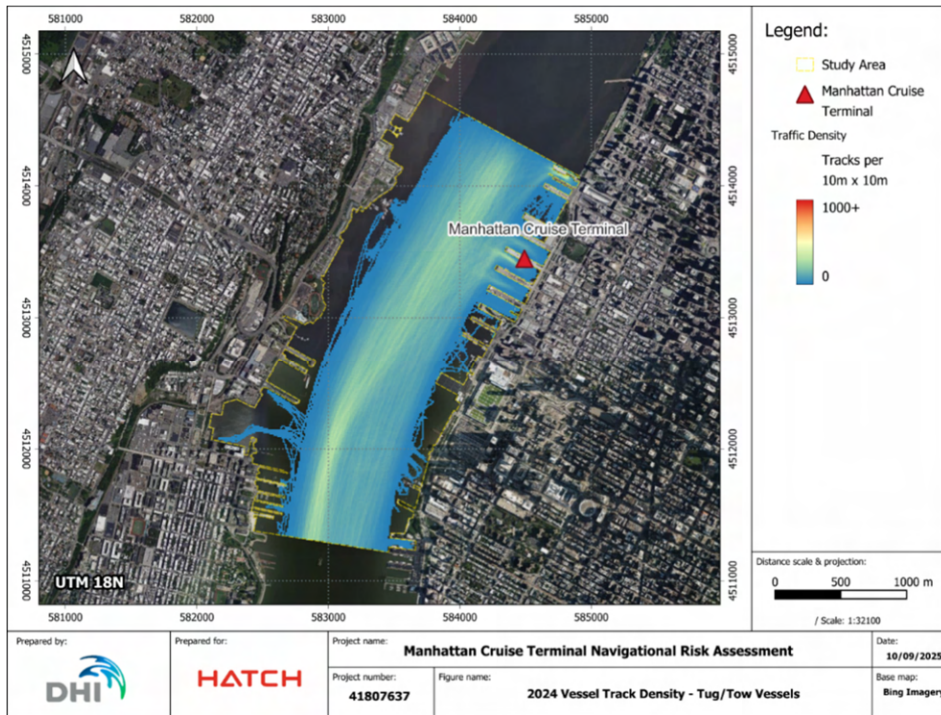


Figure F-3: 2024 Tug/Tow Vessel Track Density in Study Area

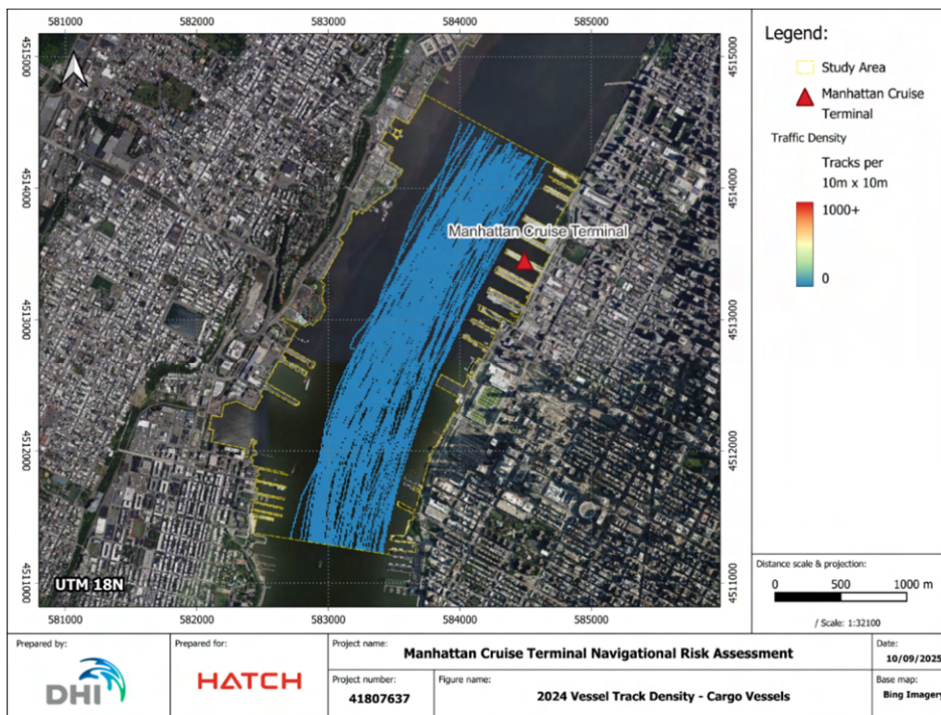
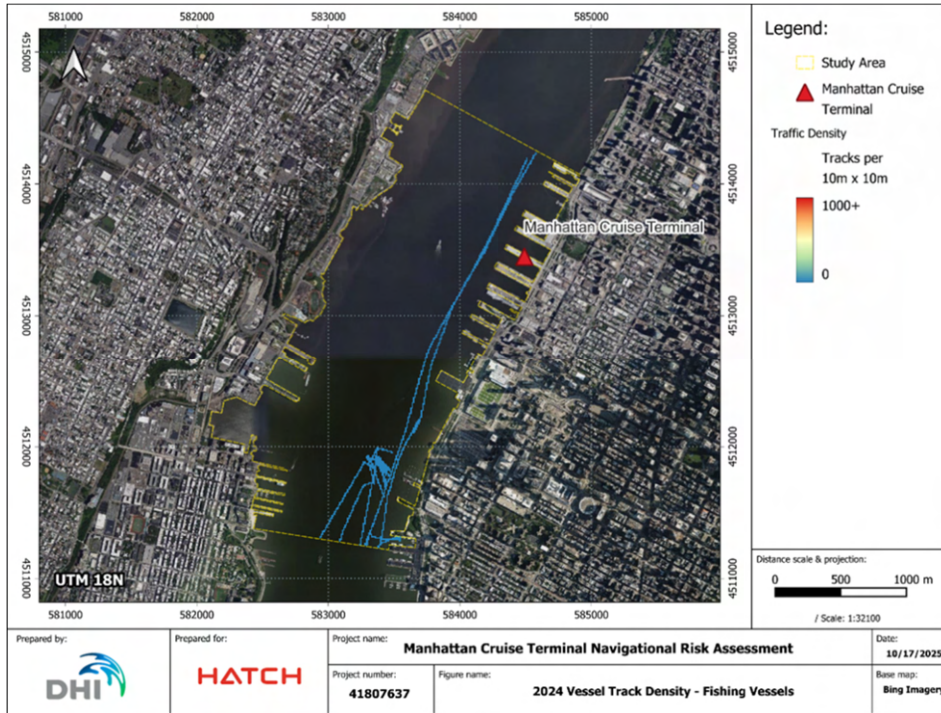
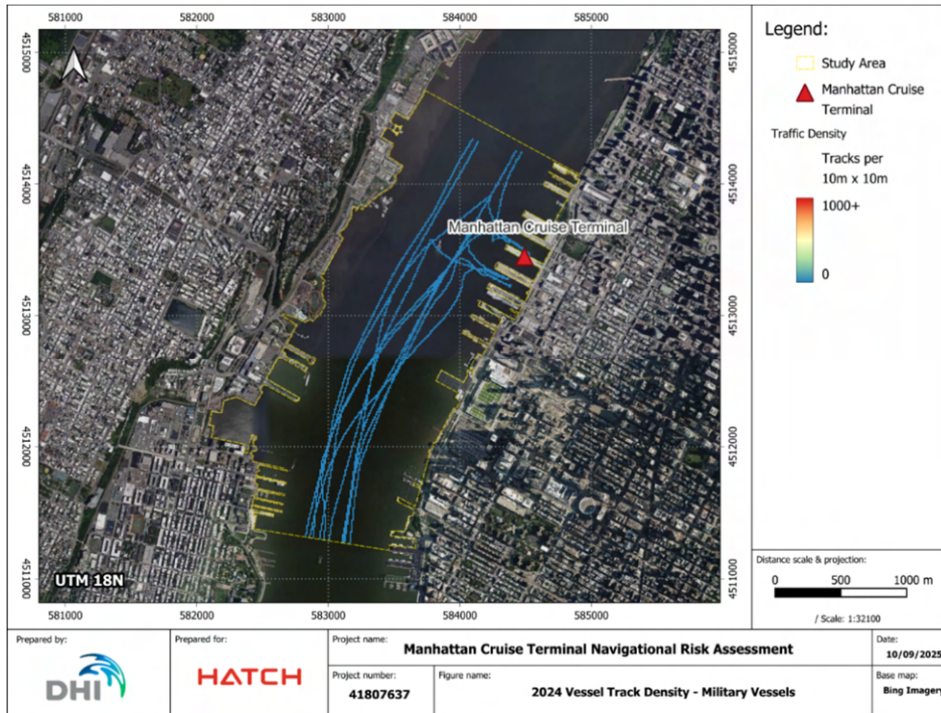


Figure F-4: 2024 Cargo Vessel Track Density in Study Area



**Figure F-5: 2024 Fishing Vessel Track Density in Study Area**



**Figure F-6: 2024 Military Vessel Track Density in Study Area**

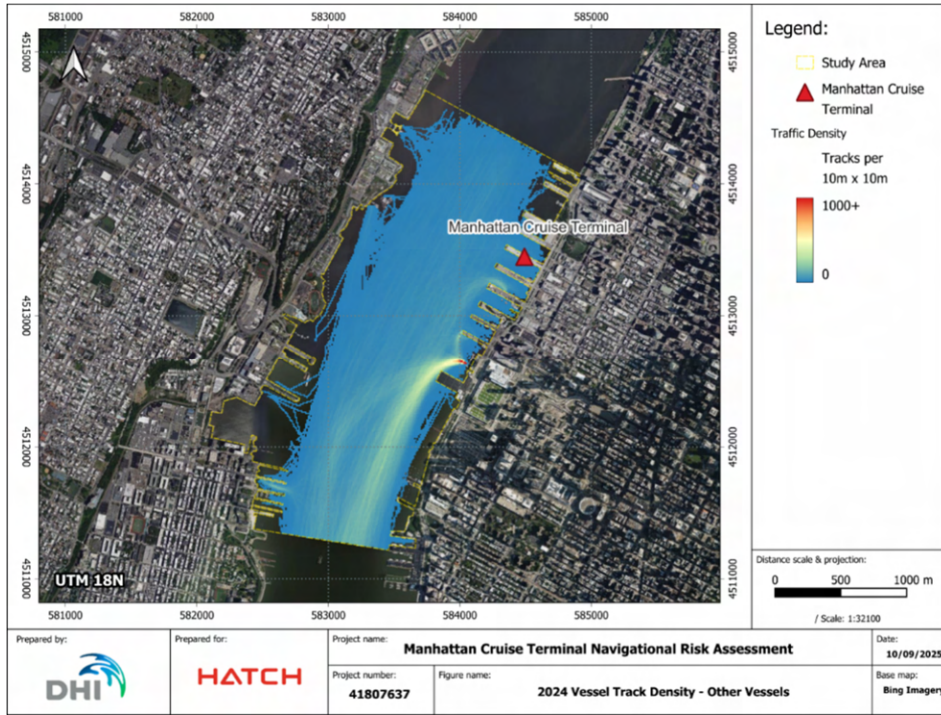


Figure F-7: 2024 Other Vessel Track Density in Study Area

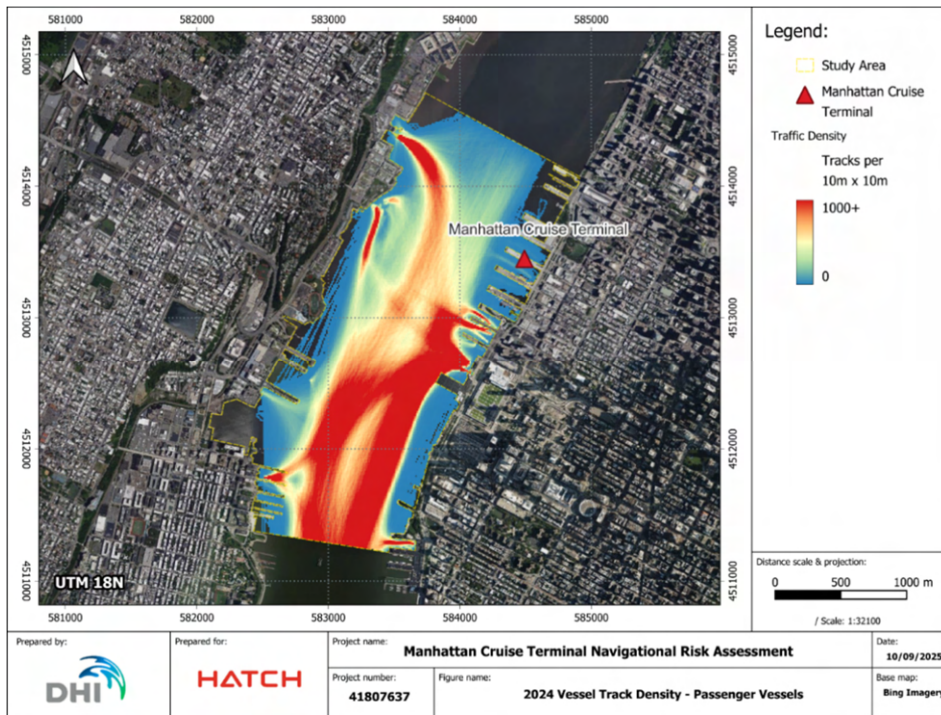
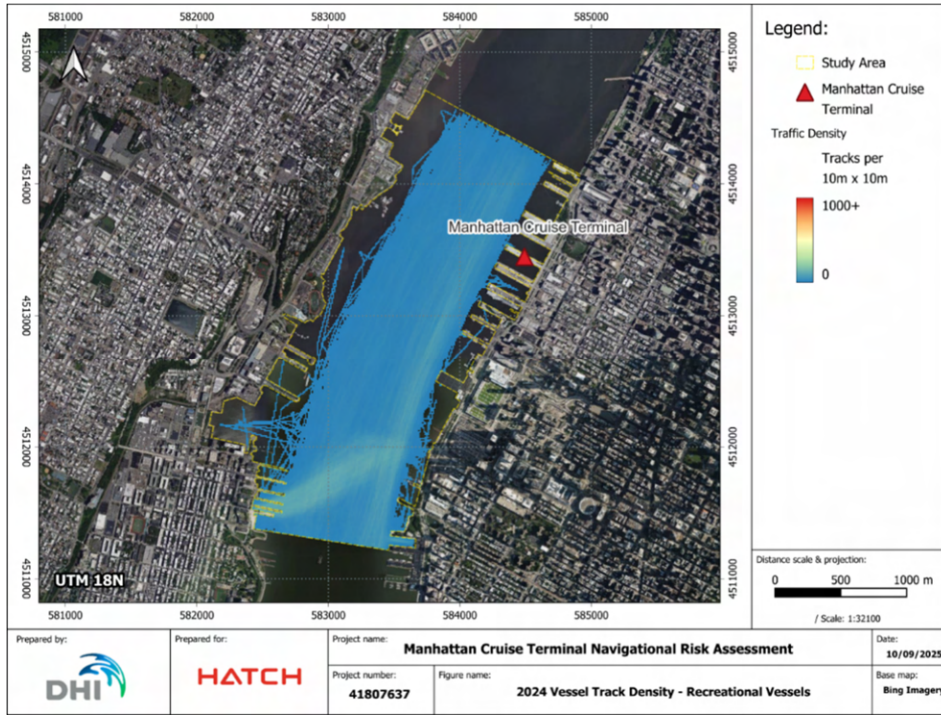
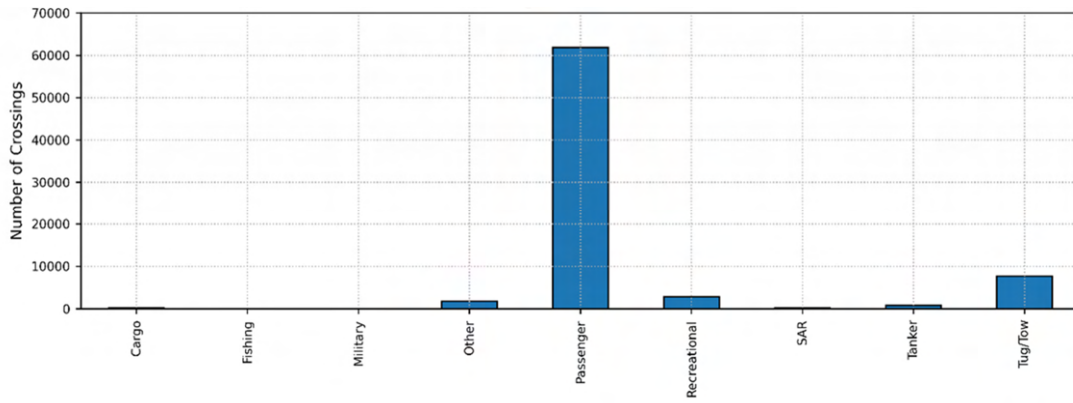


Figure F-8: 2024 Passenger Vessel Track Density in Study Area



**Figure F-9: 2024 Recreational Vessel Track Density in Study Area**

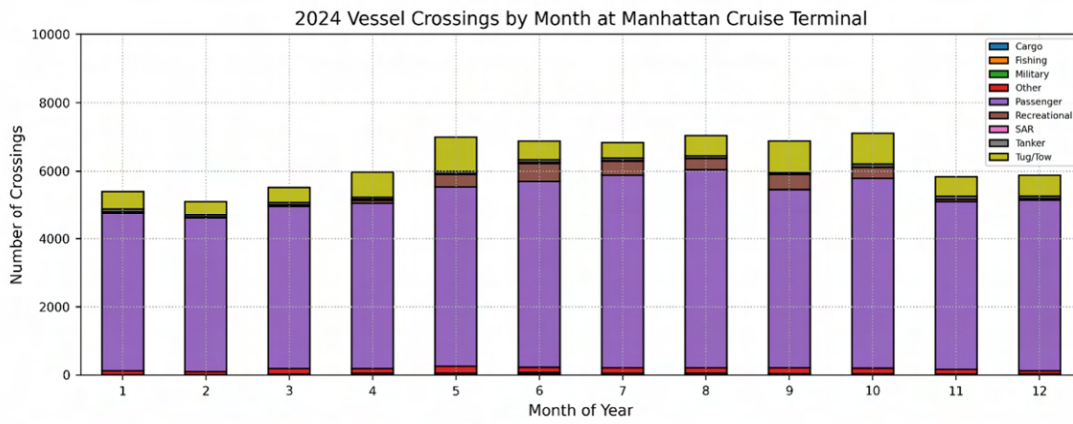
# **Appendix G: 2024 Vessel Crossing Statistics**



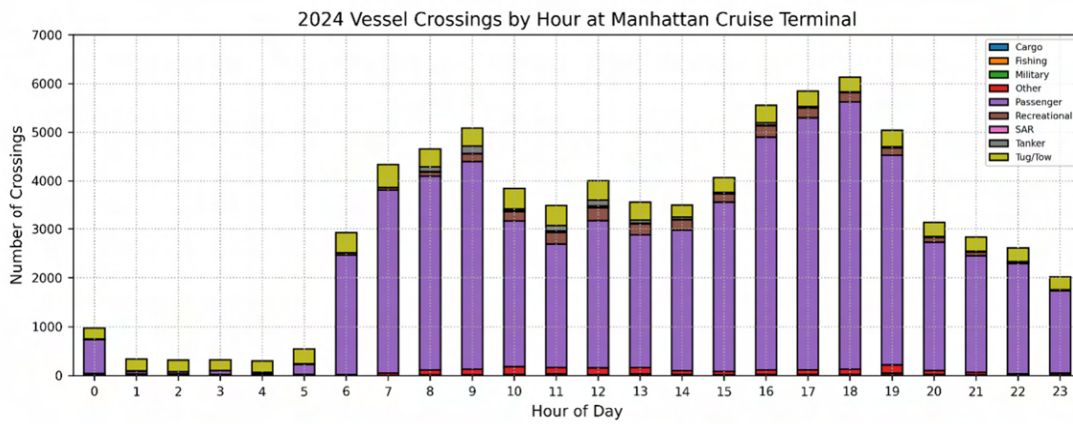
**Figure G-1: 2024 Breakdown of Vessel Crossings by Type at MCT**

**Table G-1: 2023 Breakdown of Vessel Crossings by Type at MCT**

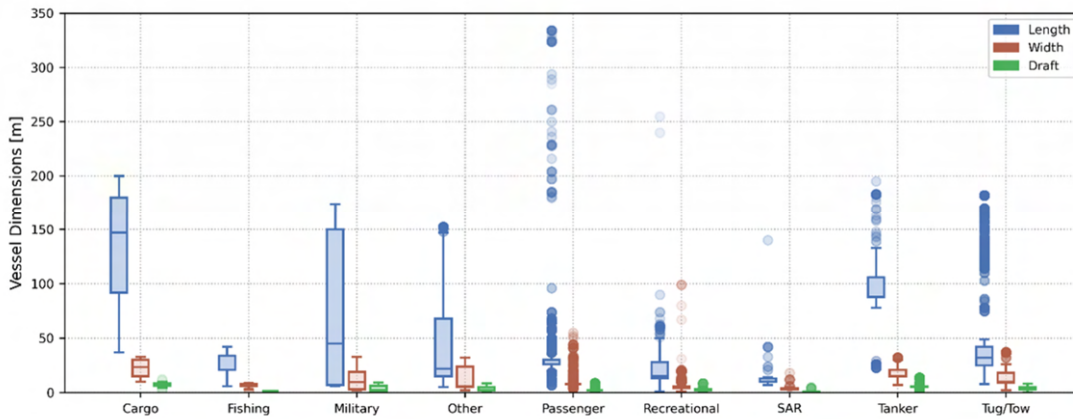
Vessel Type	Number of Crossings	Percentage of Total Crossings
Cargo	264	0.35%
Fishing	2	0.00%
Military	24	0.03%
Other	1,767	2.34%
Passenger	61,868	81.97%
Recreational	2,825	3.74%
SAR	231	0.31%
Tanker	799	1.06%
Tug/Tow	7,694	10.19%
Total	75,474	100.00%



**Figure G-2: 2024 Monthly Breakdown of Vessel Crossings by Type at MCT**



**Figure G-3: 2024 Hourly Breakdown of Vessel Crossings by Type at MCT**

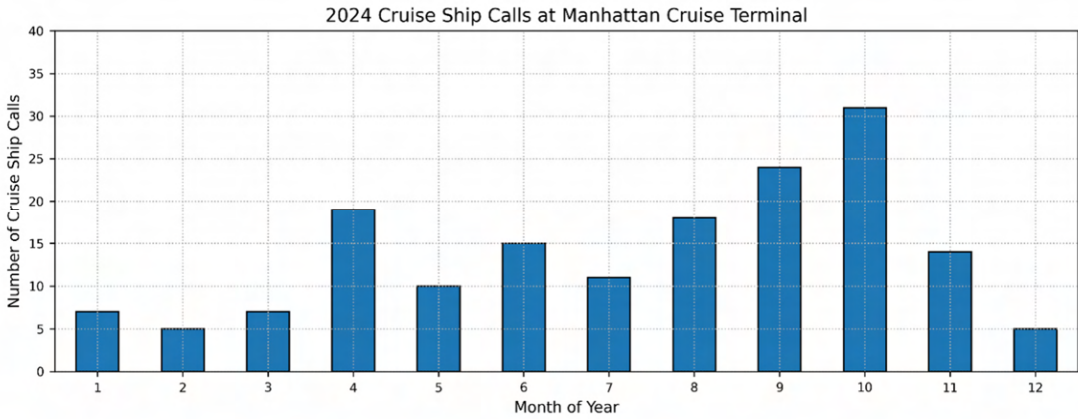
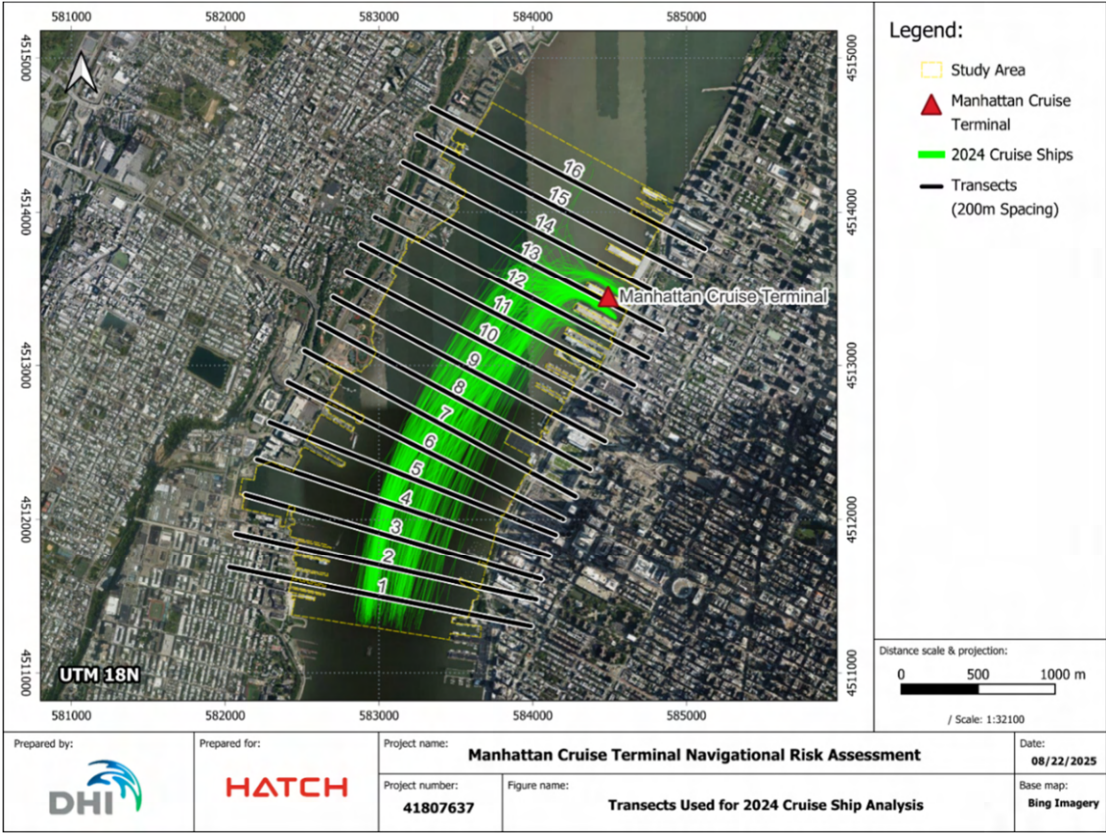


**Figure G-4: 2024 Distribution of Vessel Dimensions at MCT for Length, Width, Draft (as reported in AIS)**

**Table G-2: 2024 Breakdown of Vessel Dimensions at MCT based on Length, Width, and Draft (as reported in AIS)**

<b>Dimension/Type</b>	<b>Cargo</b>	<b>Fishing</b>	<b>Military</b>	<b>Other</b>	<b>Passenger</b>	<b>Recreational</b>	<b>SAR</b>	<b>Tanker</b>	<b>Tug/Tow</b>
Mean Length (m)	135.9	28.1	69.7	51.2	29.4	20.7	13.4	95.5	56.9
Std. Dev. Length (m)	55.0	8.9	67.2	49.3	10.2	13.3	14.0	31.9	51.1
Min. Length (m)	37.0	6.0	6.0	5.0	7.0	1.0	7.0	23.0	8.0
Max. Length (m)	200.0	42.0	174.0	152.0	334.0	255.0	140.0	195.0	182.0
Mean Width (m)	22.3	7.0	12.2	12.5	8.2	6.1	4.4	16.8	13.8
Std. Dev. Width (m)	8.2	1.7	10.1	9.2	1.6	5.3	2.2	5.3	7.8
Min. Width (m)	10.0	1.0	2.0	2.0	3.0	1.0	3.0	7.0	2.0
Max. Width (m)	33.0	9.0	33.0	32.0	55.0	99.0	18.0	32.0	37.0
Mean Draft (m)	7.3	1.3	3.8	3.9	2.1	2.9	1.2	6.3	4.5
Std. Dev. Draft (m)	1.5	0.0	3.2	1.7	0.4	1.7	1.1	3.3	1.5
Min. Draft (m)	2.7	1.3	0.8	1.0	0.2	0.4	0.5	2.0	0.4
Max. Draft (m)	12.5	1.3	9.3	8.5	8.7	8.4	5.0	13.6	8.3

## **Appendix H: 2024 Cruise Ship Calls at MCT**



**Figure H-2: 2024 Cruise Ship Calls at MCT Broken Down by Month**

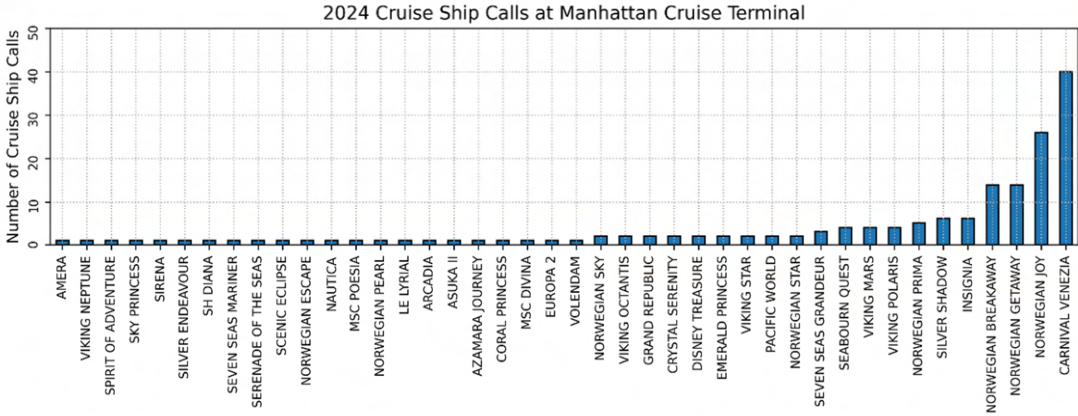


Figure H-3: 2024 Cruise Ship Calls at MCT Broken Down by Individual Vessels

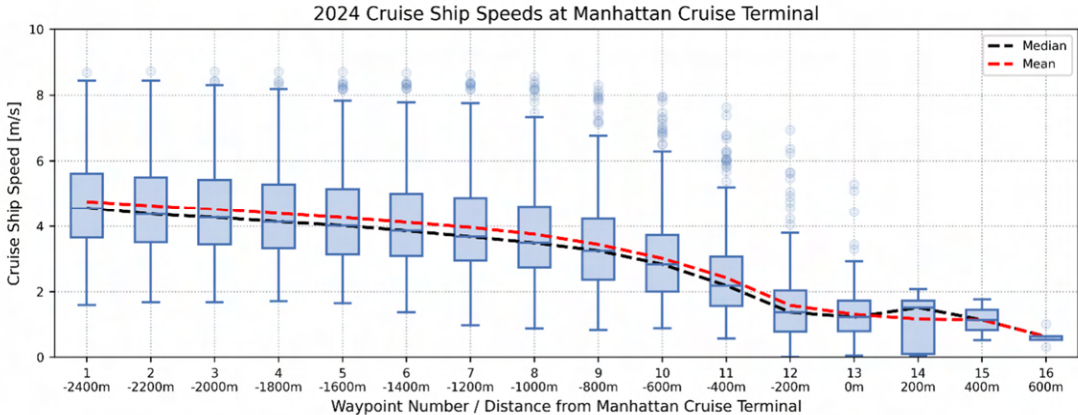


Figure H-4: 2024 Cruise Ship Speed Profiles to and from MCT

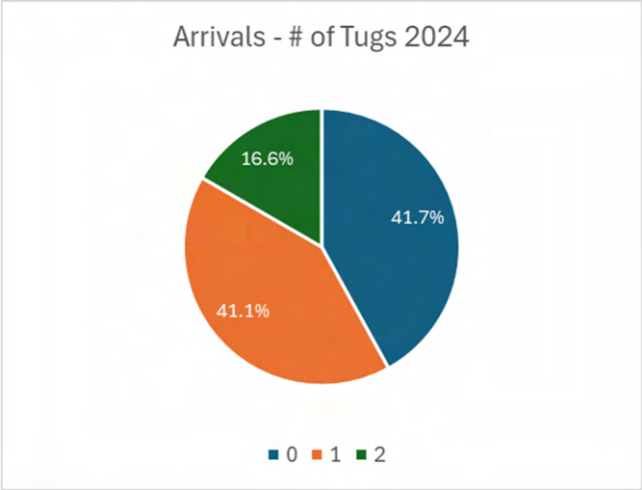


Figure H-5: 2024 Breakdown of Cruise Ship Tug Assist at MCT by Arrival (from Moran)

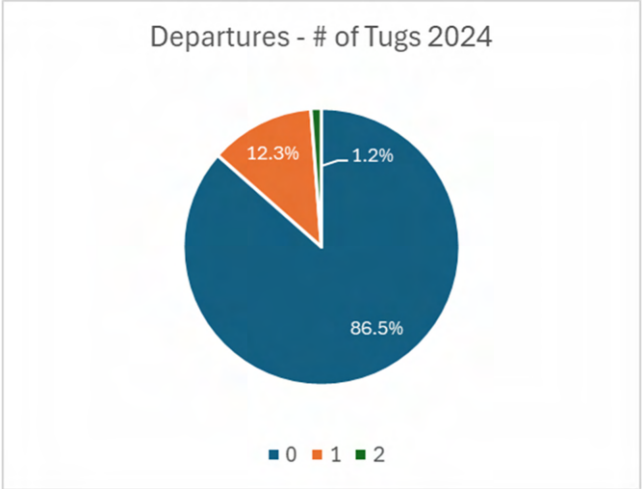
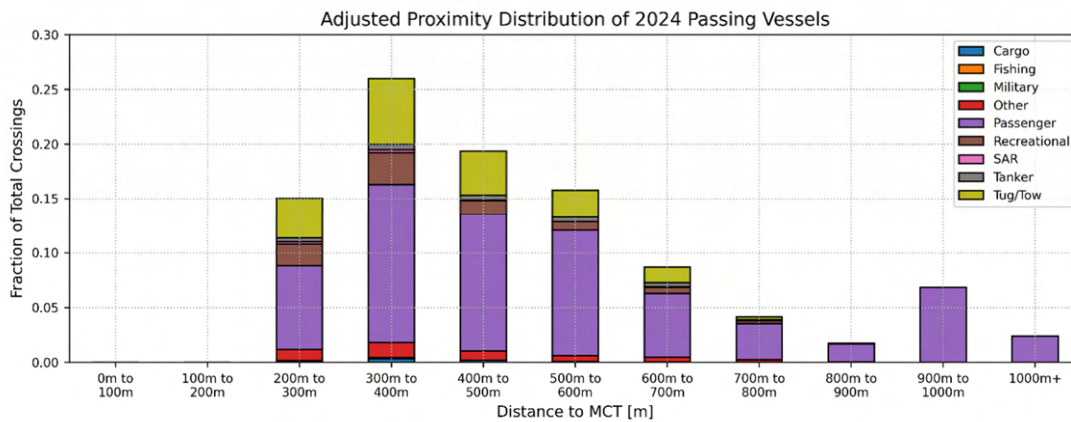


Figure H-6: 2024 Breakdown of Cruise Ship Tug Assist at MCT by Departure (from Moran)

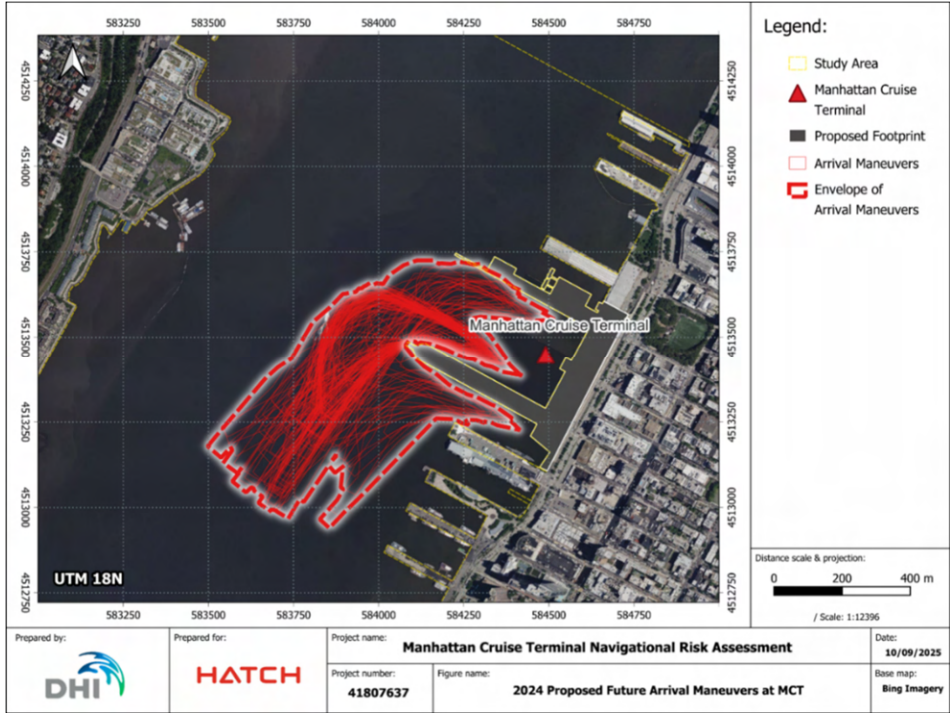
# **Appendix I: 2024 Proposed Footprint Impact Analysis**

**Table I-1: 2024 Existing Vessel Traffic Passing MCT Affected by Proposed Footprint**

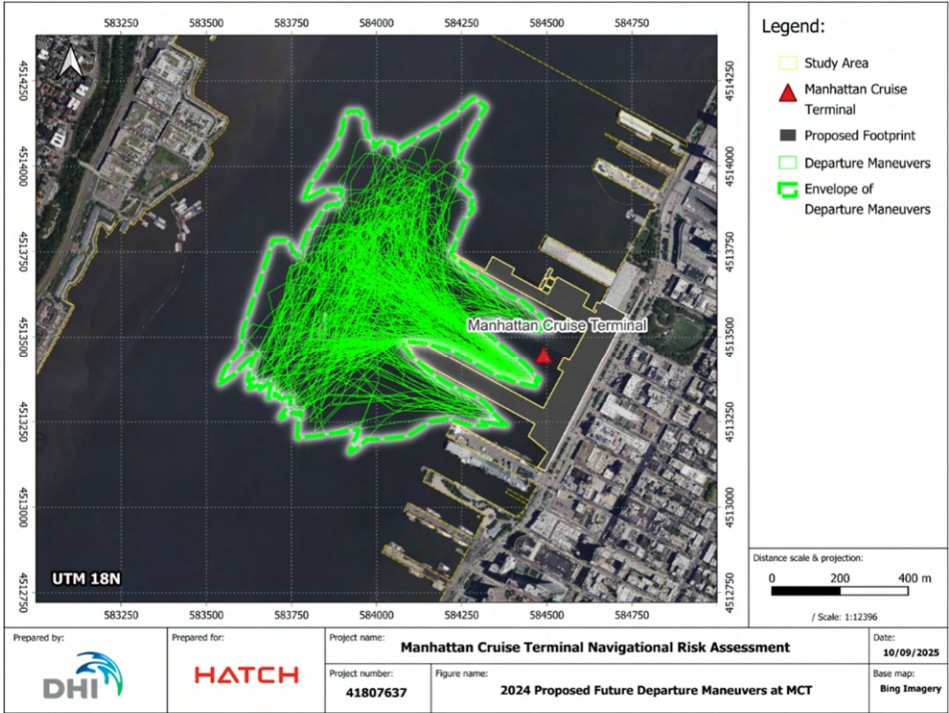
Vessel Type	Percentage of Vessel Type Traffic	Percentage of All Vessel Traffic
Cargo	7.95%	0.03%
Fishing	100.00%	0.00%
Military	16.67%	0.01%
Other	15.40%	0.36%
Passenger	4.09%	3.35%
Recreational	29.42%	1.10%
SAR	39.39%	0.12%
Tanker	8.76%	0.09%
Tug/Tow	11.15%	1.14%
All	-	6.20%



**Figure I-1: 2024 Proposed Future Passing Vessel Distance Distribution to MCT**

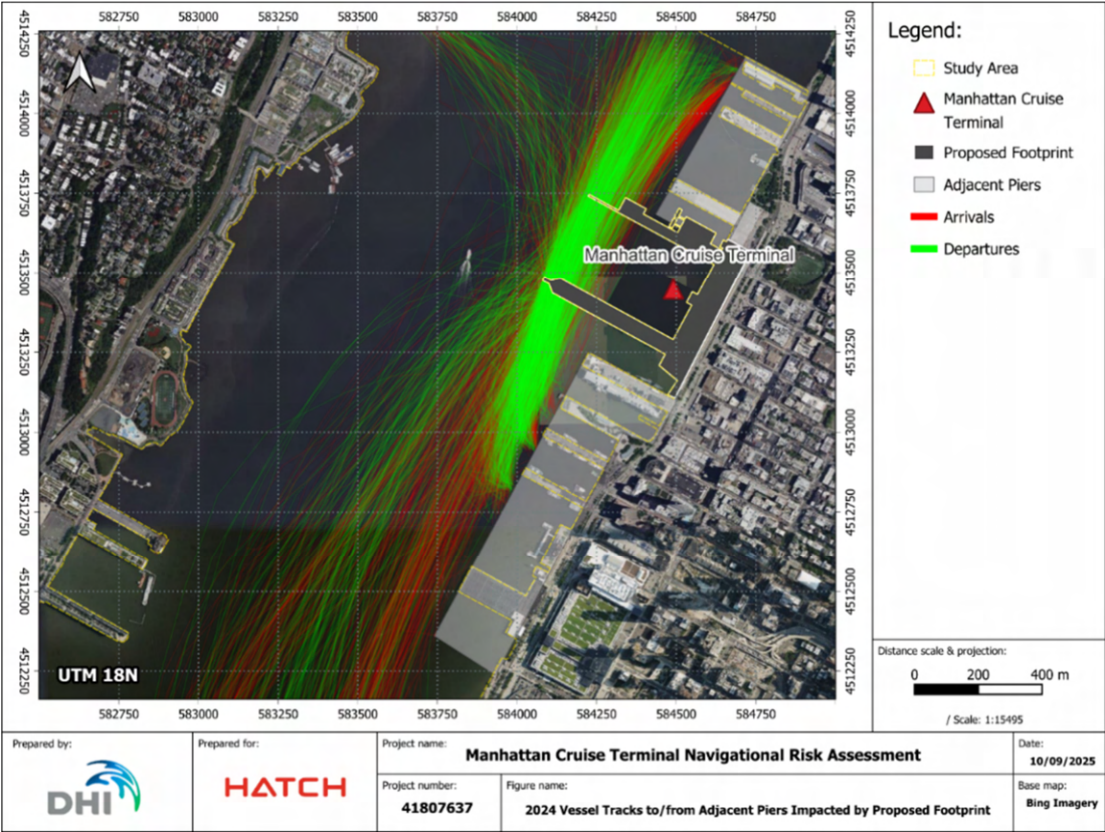


**Figure I-2: 2024 Proposed Future Cruise Ship Arrival Envelopes at MCT with Minimally Required Offset for Safe Clearance**



**Figure I-3: 2024 Proposed Future Cruise Ship Departure Envelopes at MCT with Minimally Required Offset for Safe Clearance**

New York City Economic Development Corporation - Manhattan Cruise Terminal Master Plan  
 Navigation Safety Risk Assessment - December 19, 2025



**Figure I-4: 2024 Vessel Traffic to/from Adjacent Piers Impacted by MCT Expansion**

# **Appendix J: Desktop Navigation Simulation Summary Reports**

**Table J- 1: Desktop Navigation Simulation Descriptions Using an Icon Class Vessel**

Simulation No.	Status	Berth	Aspect	Wind x Velocity	Current x Velocity
1	Arrival	88N	Bow First	NW x 25 kts.	Ebb x 2.5 kts.
2	Departure	88N	Stern First	NW x 25 kts.	Ebb x 2.5 kts.
3	Arrival	88N	Bow First	NW x 25 kts.	Flood x 2.0 kts.
4	Departure	88N	Stern First	NW x 25 kts.	Flood x 2.0 kts.
5	Arrival	92S	Stern First	NW x 25 kts.	Ebb x 2.5 kts.
6	Arrival	92S	Bow First	NE x 15 kts.	Ebb x 2.5 kts.
7	Arrival	92S	Bow First	NW x 25 kts.	Flood x 2.0 kts.
8	Departure	92S	Stern First	NW x 25 kts.	Flood x 2.0 kts.
9	Arrival	88N	Bow First	SW x 25 kts.	Flood x 2.0 kts.
10	Departure	88N	Stern First	SW x 25 kts.	Flood x 2.0 kts.
11	Arrival	92S	Bow First	NW x 25 kts. + 10min 35kts gust	Ebb x 2.5 kts.
12	Departure	92S	Stern First	NW x 25 kts. + 10min 35kts gust	Ebb x 2.5 kts.

## Run 1

Berth	88N	Route/Duration	Arrival / 33 mins
Maneuver	IN Bow First	Alongside	Starboard
Current	Ebb x 2.5 kts.	Wind	(NW) 315° x 25kt
Maneuver Grade	Moderate	Completion Status	Marginal
AziPod 0 (Stbd)	76%	Bow Tr.Pair No.1	100%
AziPod 1 (Port)	65%	Bow Tr.Pair No.2	100%

**Comment:**

The ship starts at approximately 0.4 nautical miles southwest of Pier 88, inbound for Pier 88N with a bow-in, starboard-side-alongside approach. One tug was secured to the port shoulder near the bow.

Initially, the ship was making a heading of 019° at 3.5 knots with a drift angle of approximately 013° to starboard due to a strong north-westerly wind. Speed was gradually reduced to about 1 knot while monitoring the ship's heading and the increasing drift angle.

A starboard swing was initiated when the ship's bow was in line with Pier 92S. The bow and stern swing were controlled to steer the ship into the MCT pier basin. Both forward speed and the rate of turn were continuously checked.

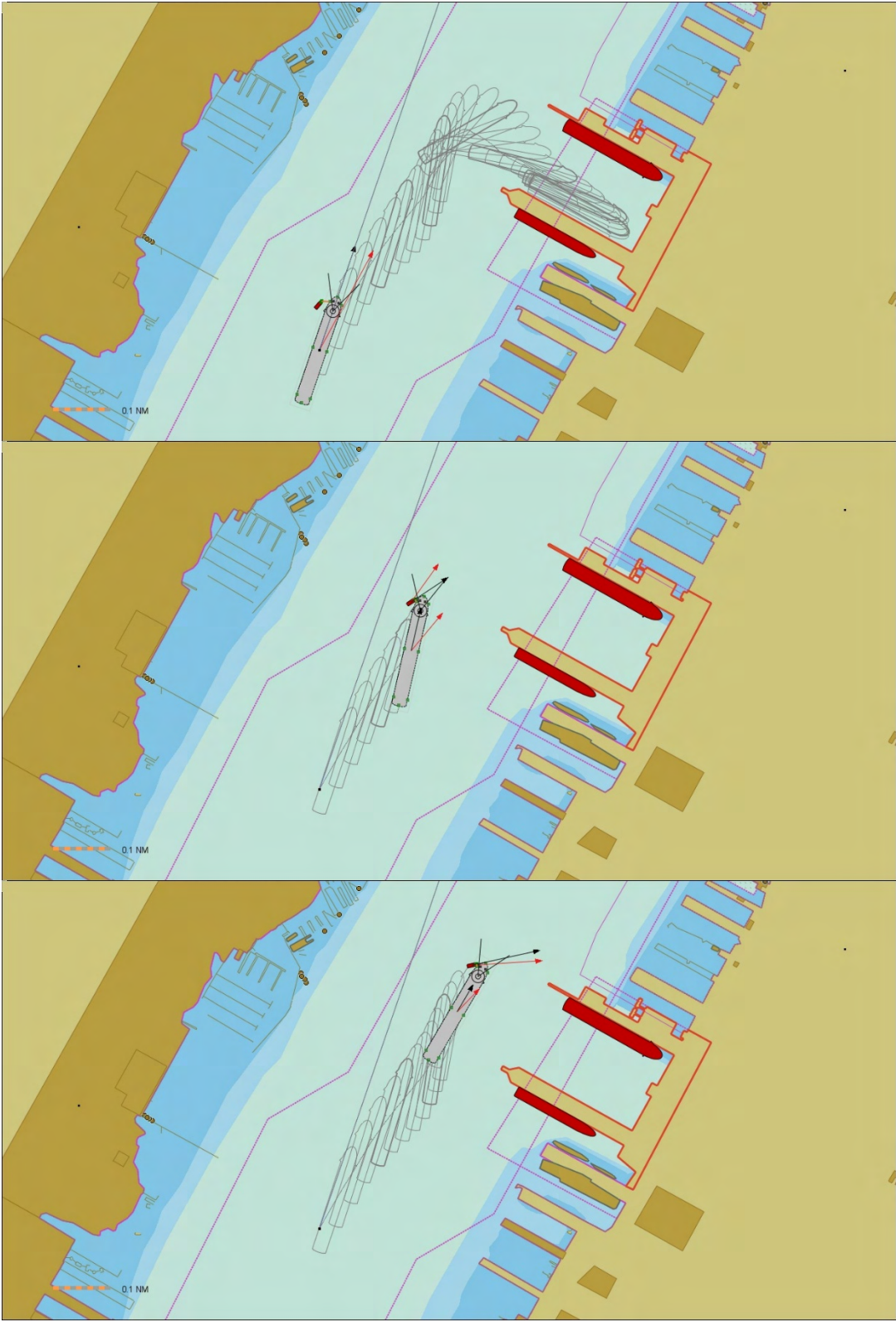
100% power was required on the bow thruster to control the bow. Control improved as the ship moved further into the MCT pier basin and away from the influence of tidal current.

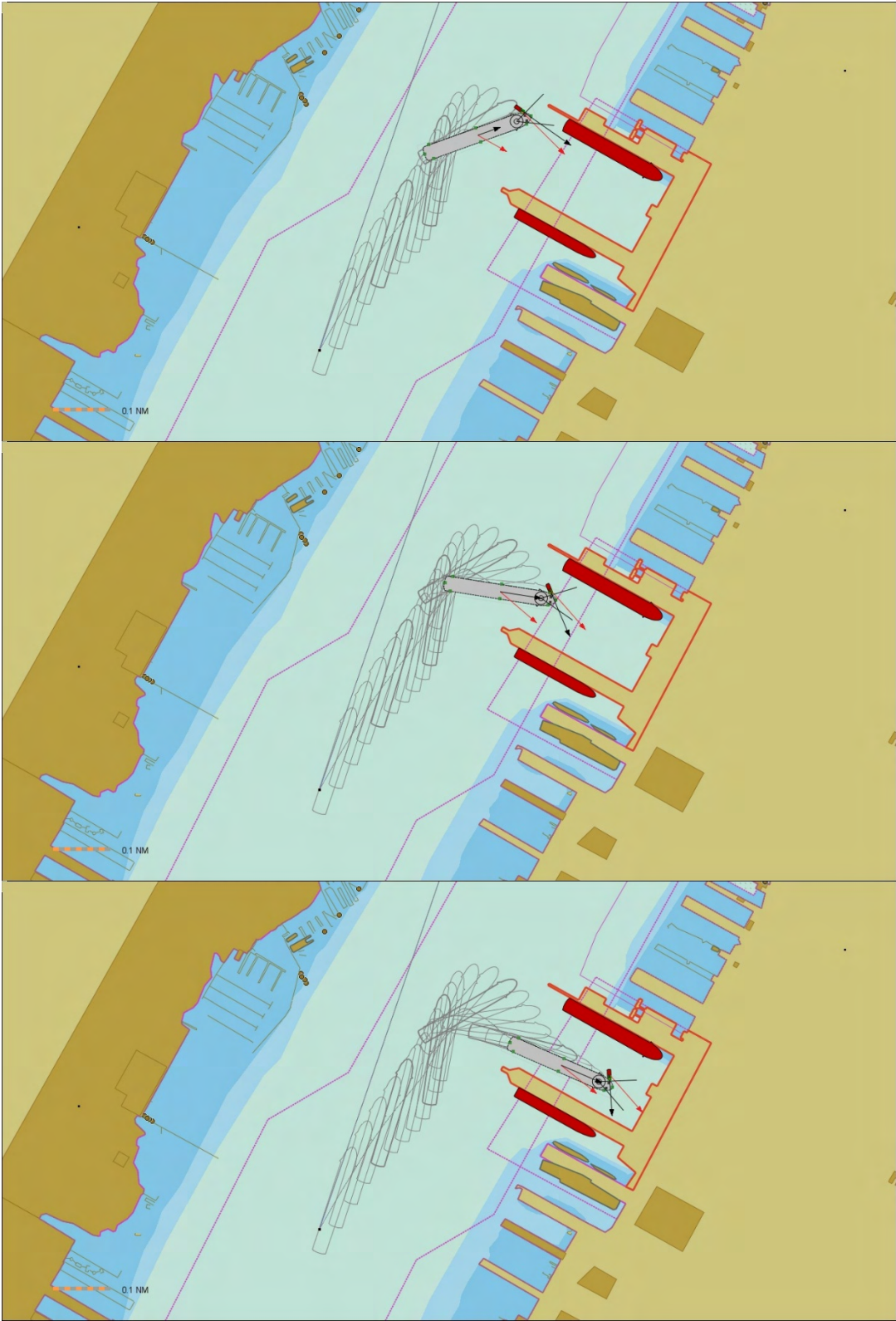
The ship had sufficient resources to berth successfully and in a controlled manner. The entire berthing operation took 33 minutes until the ship was in a safe position to send out mooring lines. Tug assistance and power was not used during the run.

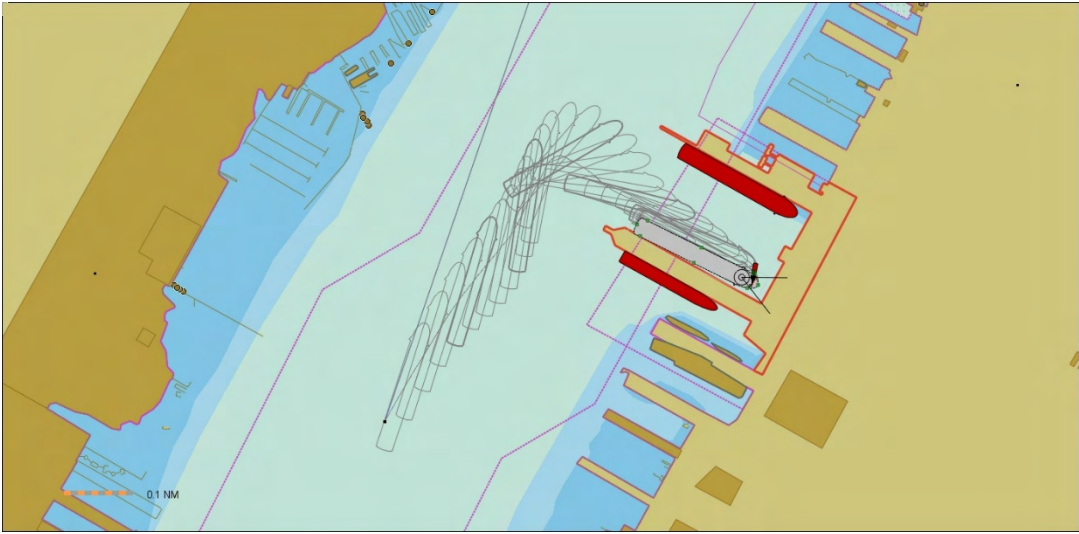
The maneuver required constant attention and alertness to control the ship's transverse and lateral speed. The ship-handling maneuver was graded as MODERATE.

The completion status of the simulation run was graded as MARGINAL because maximum bow thruster power was required continuously or for a prolonged period during the maneuver.

Select snapshots of the run simulation are provided in the images below at key points through the maneuver.







## Run 2

Berth	88N	Route/Duration	Depart / 21 mins
Maneuver	Back out-Stern first	Alongside	Starboard
Current	Ebb x 2.5 kts.	Wind	(NW) 315° x 25kt
Maneuver Grade	Easy	Completion Status	Successful
AziPod 0 (Stbd)	85%	Bow Tr.Pair No.1	90%
AziPod 1 (Port)	85%	Bow Tr.Pair No.2	92%

**Comment:**

The ship started docked starboard side alongside Pier 88N. One tug was secured to the port shoulder near the bow.

Slow power on the AziPod stern thrusters and bow thrusters was used to pull the ship parallel off the pier.

Once the ship had cleared the berth by approximately one beam width, astern power was applied to back the ship out, stern first, at a controlled speed to exit the MCT pier basin as quickly as possible.

When the ship's bow cleared the end tip of Pier 88, the bow thrusters and stern thrusters were used to swing the ship to starboard while still moving astern.

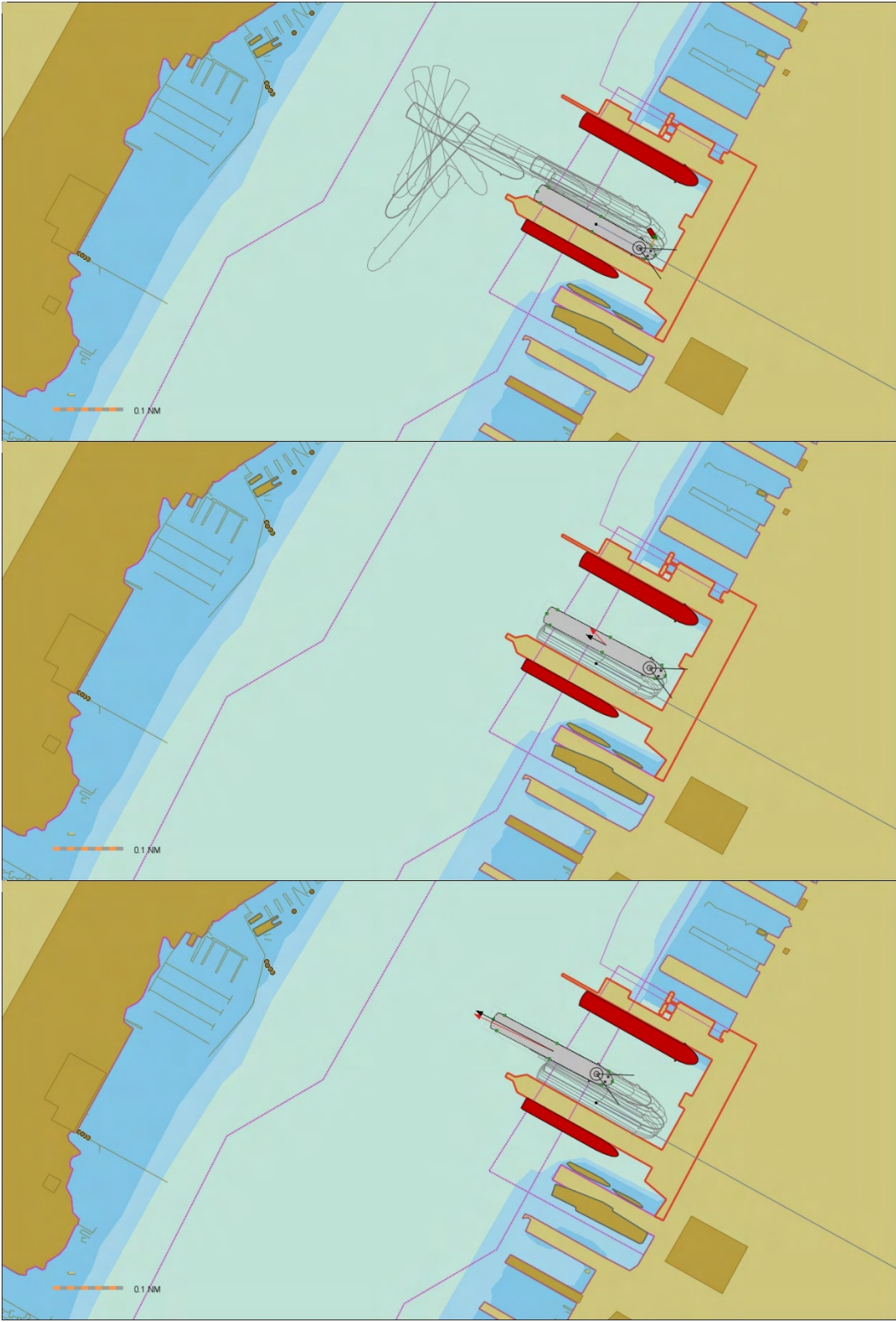
The ship's rate of turn and speed were monitored to align the bow for an outbound heading toward the southwest, taking into consideration the drift angle caused by wind and tidal current. The ship was then put ahead to steer out on its own power. Tug assistance and power was not used during the run.

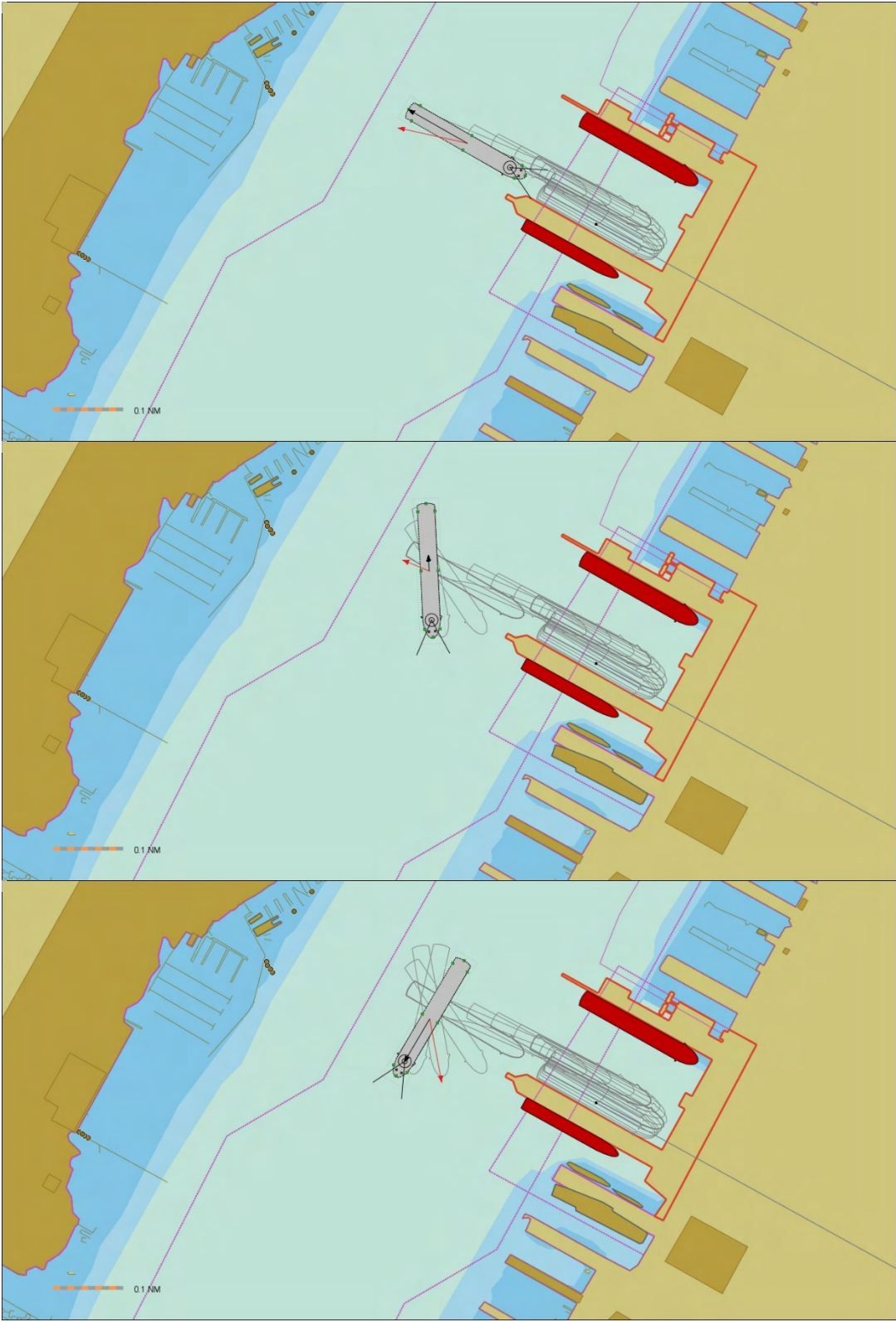
The ship had sufficient resources to unberth and maneuver outbound in a controlled manner, and there were no significant concerns during the operation. The entire run took 21 minutes until the ship reached a safe outbound position. The run was comfortable.

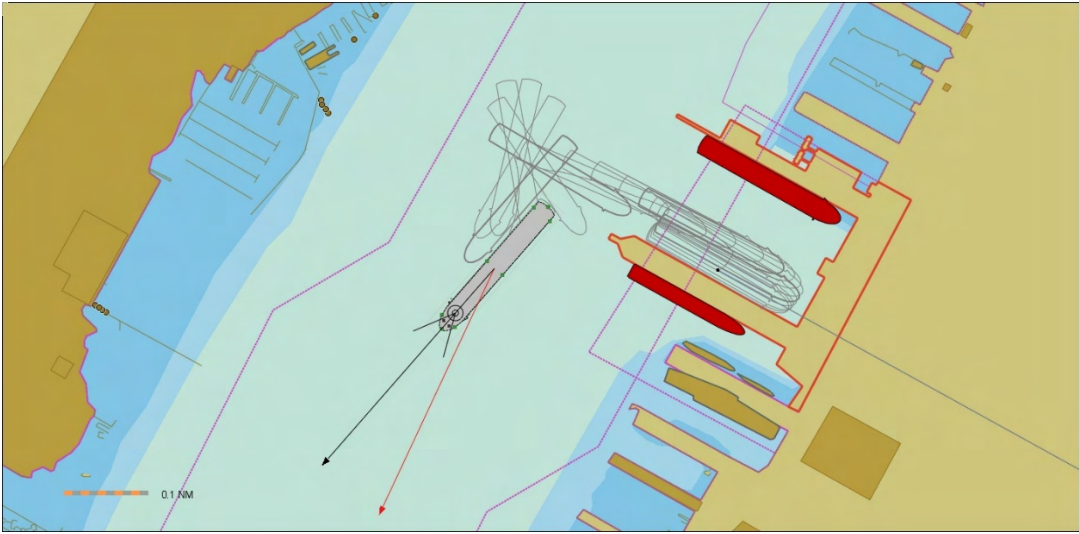
The ship-handling maneuver was graded as EASY.

The completion status of the simulation run was graded as SUCCESSFUL.

Select snapshots of the run simulation are provided in the images below at key points through the maneuver.







## Run 3

Berth	88N	Route/Duration	Arrival / 18 mins
Maneuver	IN Bow First	Alongside	Starboard
Current	Flood x 2.0 kts.	Wind	(NW) 315° x 25kt
Maneuver Grade	Moderate	Completion Status	Successful
AziPod 0 (Stbd)	79%	Bow Tr.Pair No.1	79%
AziPod 1 (Port)	64%	Bow Tr.Pair No.2	67%

**Comment:**

The ship starts at approximately 0.4 nautical miles southwest of Pier 88, inbound for Pier 88N with a bow-in, starboard-side-alongside approach.

Initially, the ship was making a heading of 017° at 3.8 knots with a drift angle of approximately 020° to starboard due to a strong north-westerly wind and tidal current at ship's quarter.

When the ship's bow was in line with end tip of Pier 88, starboard swing was initiated to enter the MCT pier basin. The ship speed was also reduced quickly. Bow thrusters were used to assist in the swing.

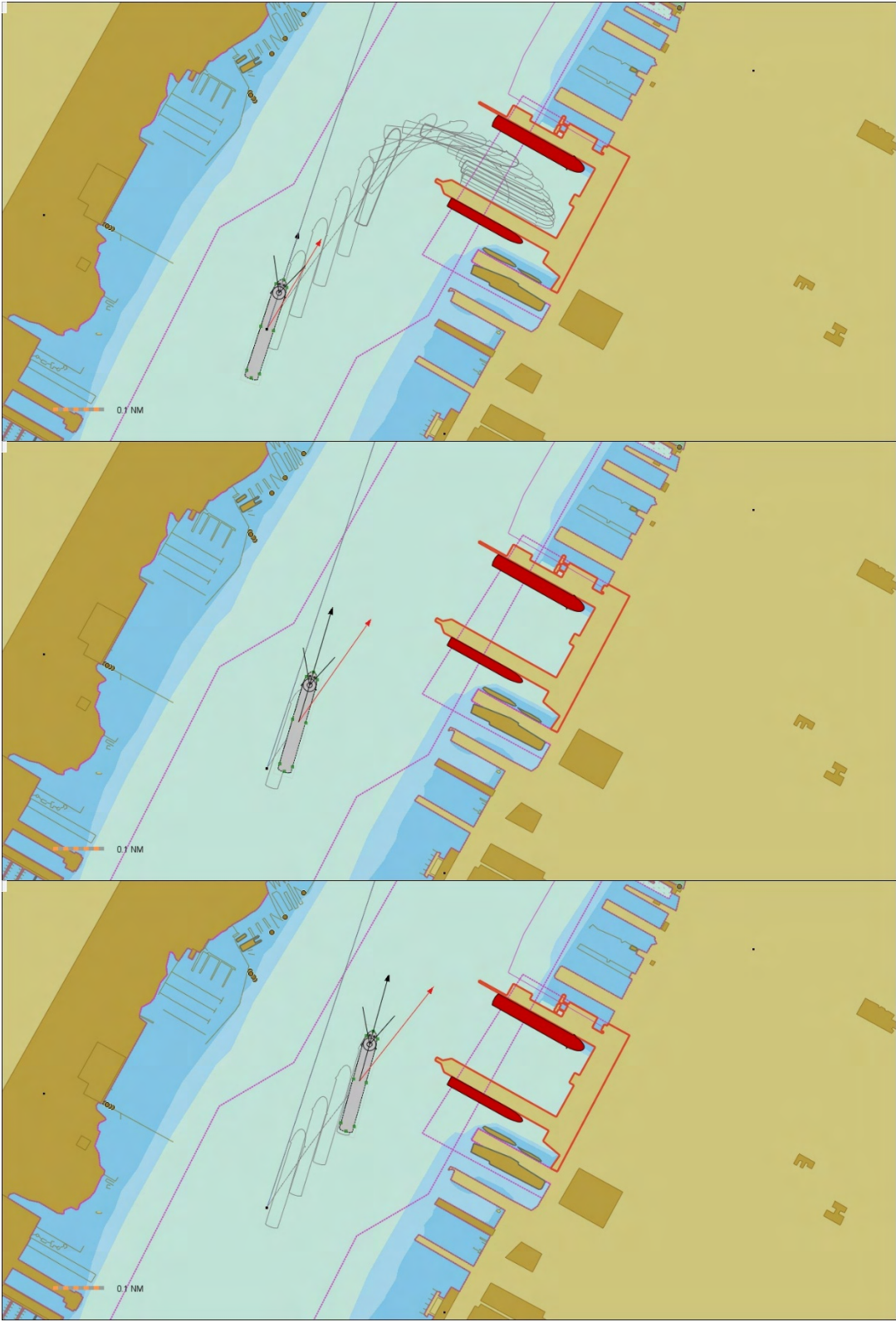
The bow and stern swing were controlled to steer the ship into the MCT pier basin. Both forward speed and the rate of turn were continuously checked. Control improved as the ship moved further into the MCT pier basin and away from the influence of tidal current.

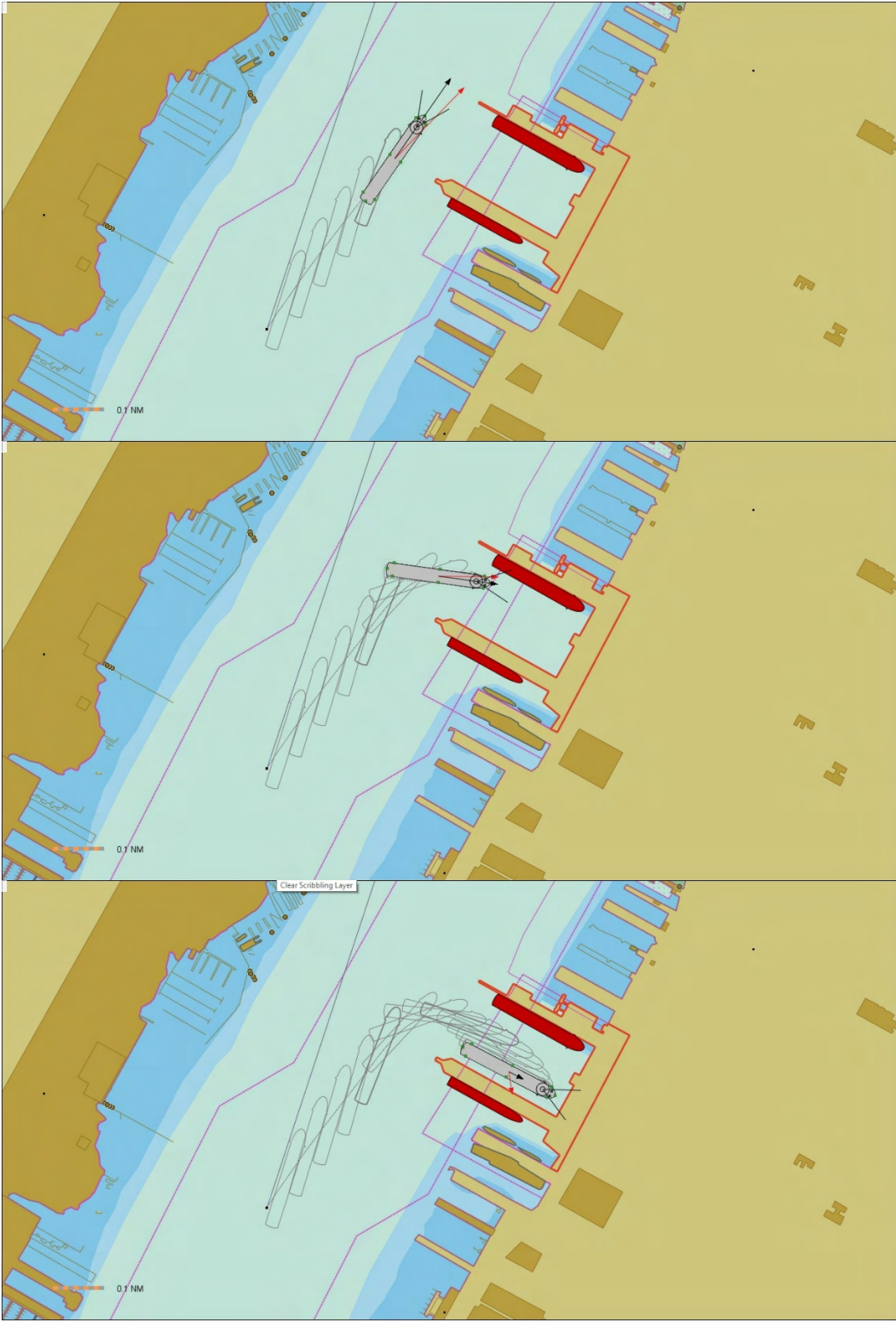
The ship had sufficient resources to berth successfully and in a controlled manner. The entire berthing operation took 18 minutes until the ship was in a safe position to send out mooring lines.

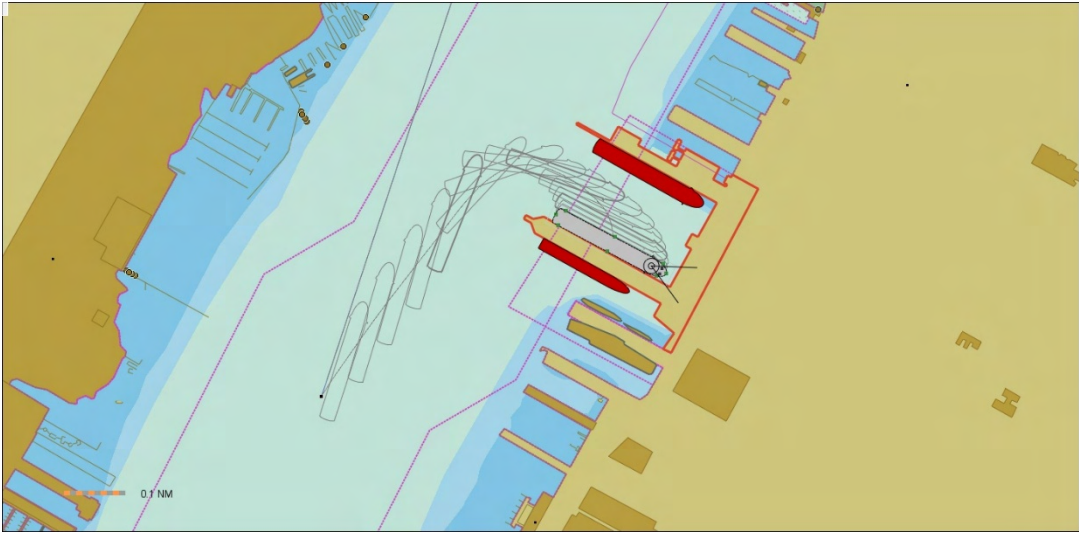
The maneuver required constant attention and alertness to control the ship's transverse and lateral speed and large drift angle. The ship-handling maneuver was graded as MODERATE.

The completion status of the simulation run was graded as SUCCESSFUL.

Select snapshots of the run simulation are provided in the images below at key points through the maneuver.







## Run 4

Berth	88N	Route/Duration	Depart / 20 mins
Maneuver	Back out-Stern first	Alongside	Starboard
Current	Flood x 2.0 kts.	Wind	(NW) 315° x 25kt
Maneuver Grade	Easy	Completion Status	Successful
AziPod 0 (Stbd)	67%	Bow Tr.Pair No.1	50%
AziPod 1 (Port)	80%	Bow Tr.Pair No.2	51%

**Comment:**

The ship started docked starboard side alongside Pier 88N.

Slow power on the AziPod stern thrusters and bow thrusters was used to pull the ship parallel off the pier.

Once the ship had cleared the berth by approximately half beam width, astern power was applied to back the ship out, stern first, at a controlled speed to exit the MCT pier basin as quickly as possible.

When the ship's bow cleared the end tip of Pier 88, the bow thrusters and stern thrusters were used to swing the ship to starboard while still moving astern.

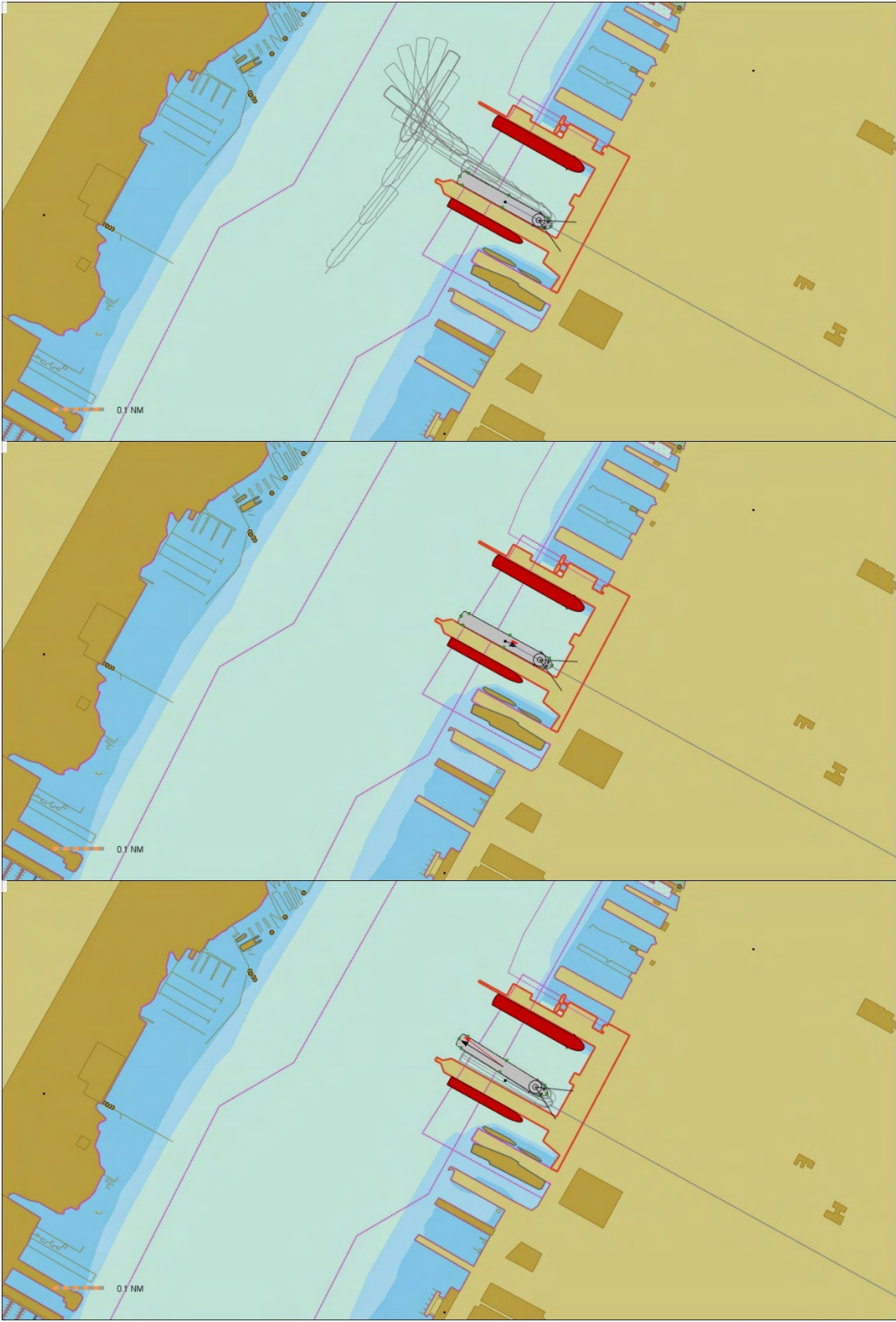
The ship's rate of turn and speed were monitored to align the bow for an outbound heading toward the southwest, taking into consideration the drift angle caused by wind and tidal current. The ship was then put ahead to steer out on its own power.

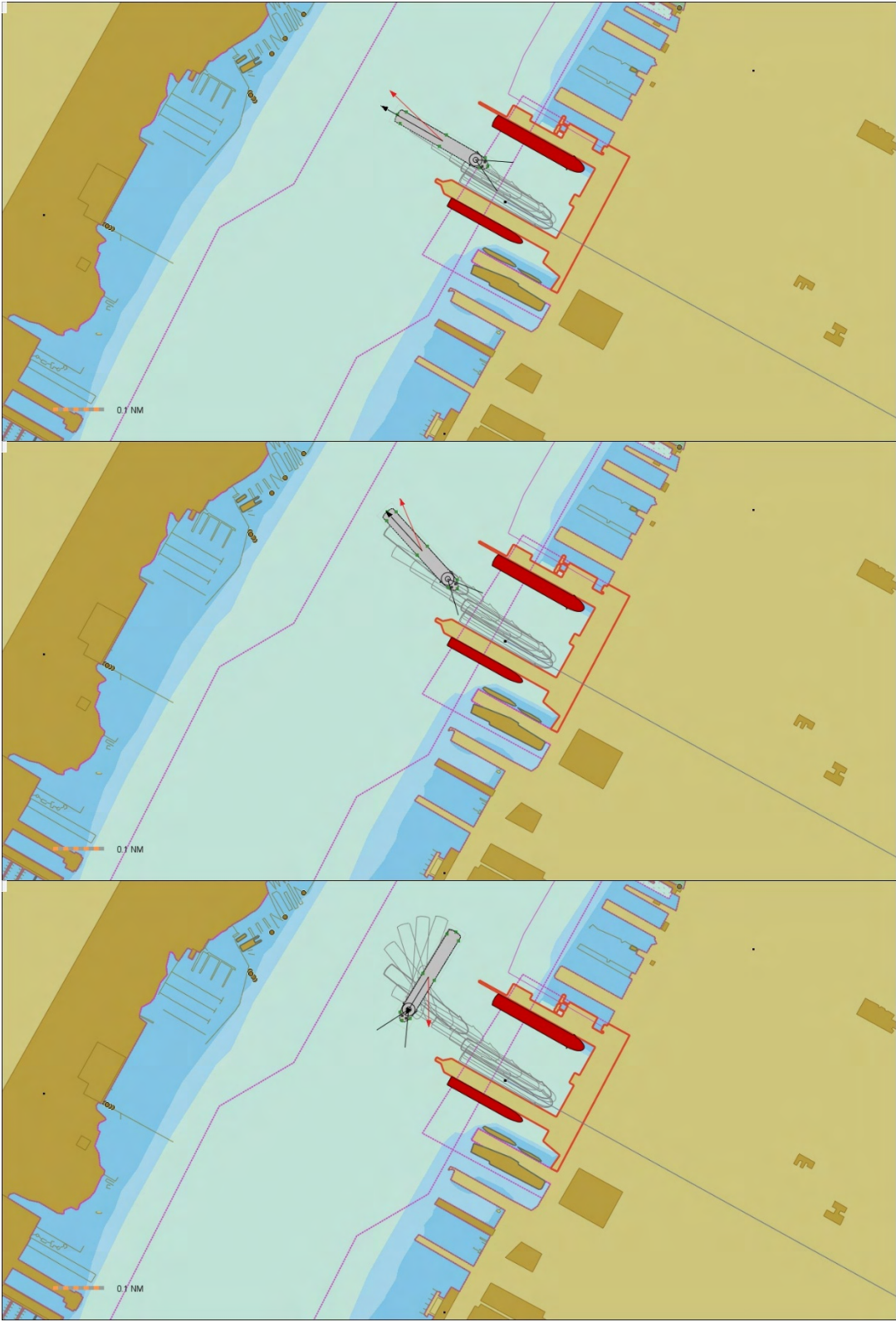
The ship had sufficient resources to unberth and maneuver outbound in a controlled manner, and there were no significant concerns during the operation. The entire run took 20 minutes until the ship reached a safe outbound position. The run was comfortable.

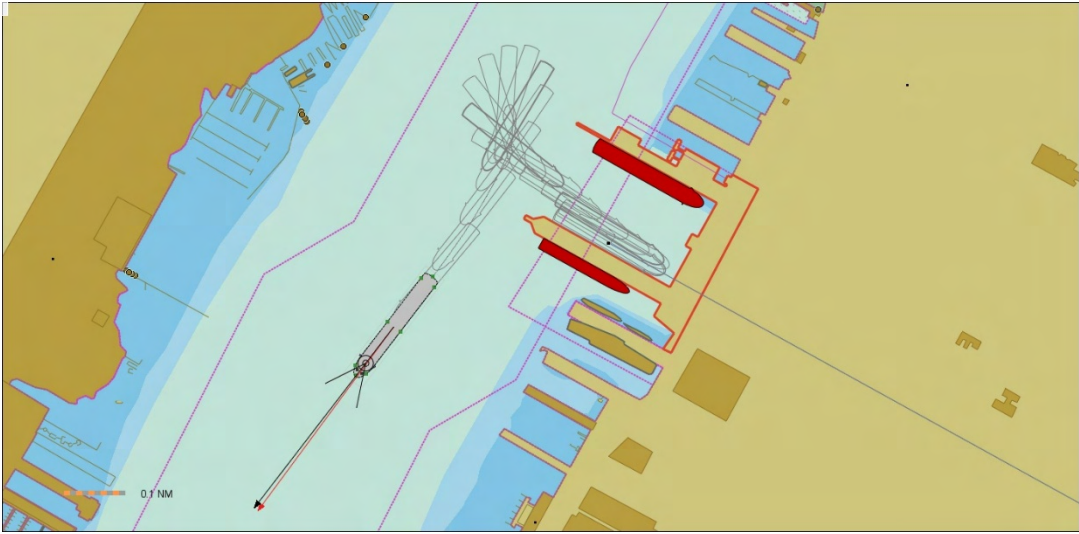
The ship-handling maneuver was graded as EASY.

The completion status of the simulation run was graded as SUCCESSFUL.

Select snapshots of the run simulation are provided in the images below at key points through the maneuver.







## Run 5

Berth	92S	Route/Duration	Arrival / 46 mins
Maneuver	Back-IN-Stern First	Alongside	Starboard
Current	Ebb x 2.5 kts.	Wind	(NW) 315° x 25kt
Maneuver Grade	Moderate	Completion Status	Successful
AziPod 0 (Stbd)	86%	Bow Tr.Pair No.1	84%
AziPod 1 (Port)	85%	Bow Tr.Pair No.2	88%

**Comment:**

The ship starts at approximately 0.4 nautical miles southwest of Pier 88, inbound for Pier 92S with a back-in stern first, starboard-side-alongside approach. One tug was secured to the port shoulder near the bow.

Initially, the ship was making a heading of 019° at 3.5 knots with a drift angle of approximately 013° to starboard due to a strong north-westerly wind. Speed was gradually reduced to zero while continuously monitoring the ship's heading and the increasing drift angle.

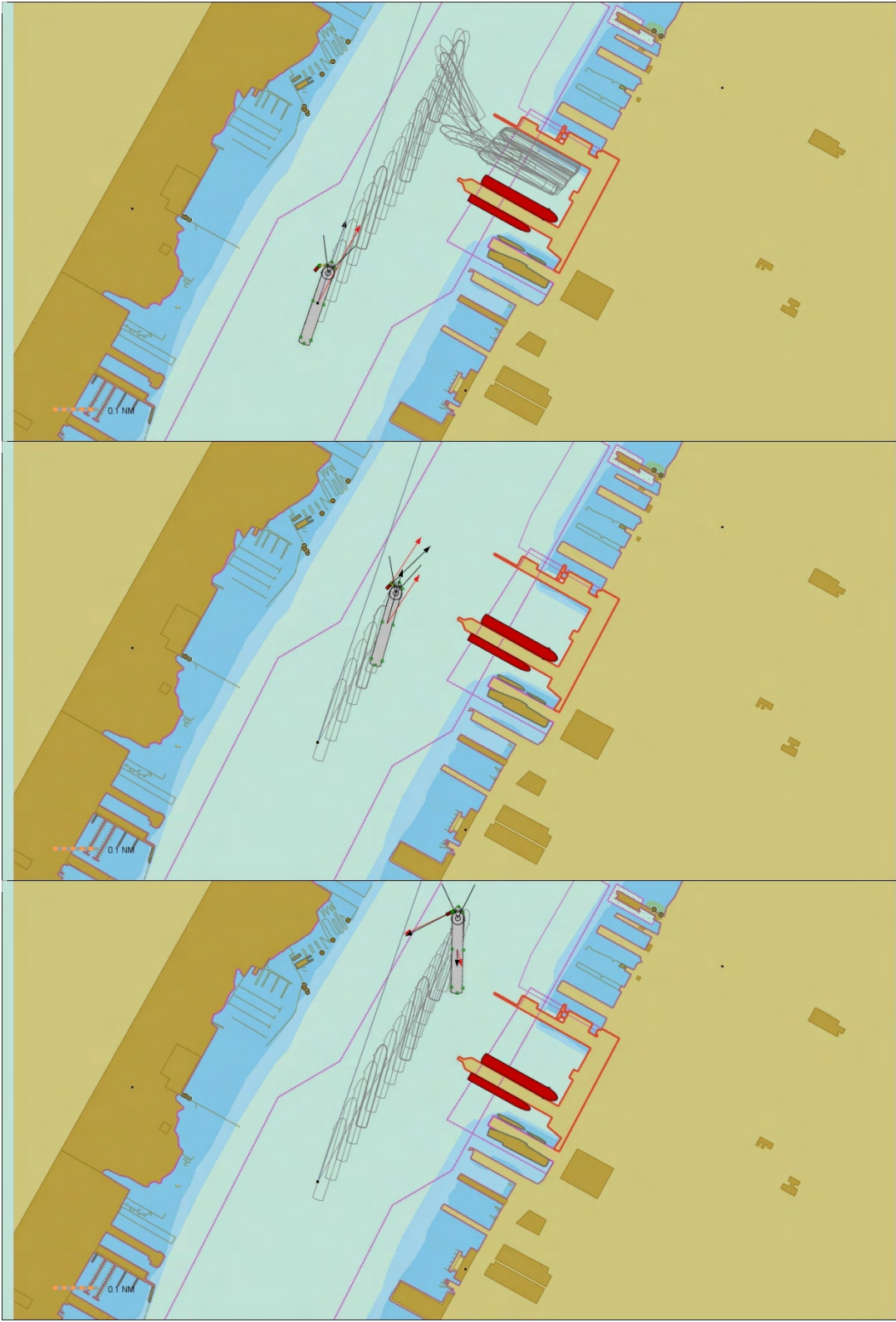
When the ship's speed reaches zero and the stern was in line with Pier 92S, the ship heading was turned to port, allowing the ebb current to act along the ship starboard side. As the current pushes on the ship's starboard side and ship began moving astern, the bow and stern swing were controlled to steer the ship's stern into the MCT pier basin. Both astern speed and the rate of turn were continuously checked. Control improved as the ship moved further into the MCT pier basin and away from the influence of the tidal current.

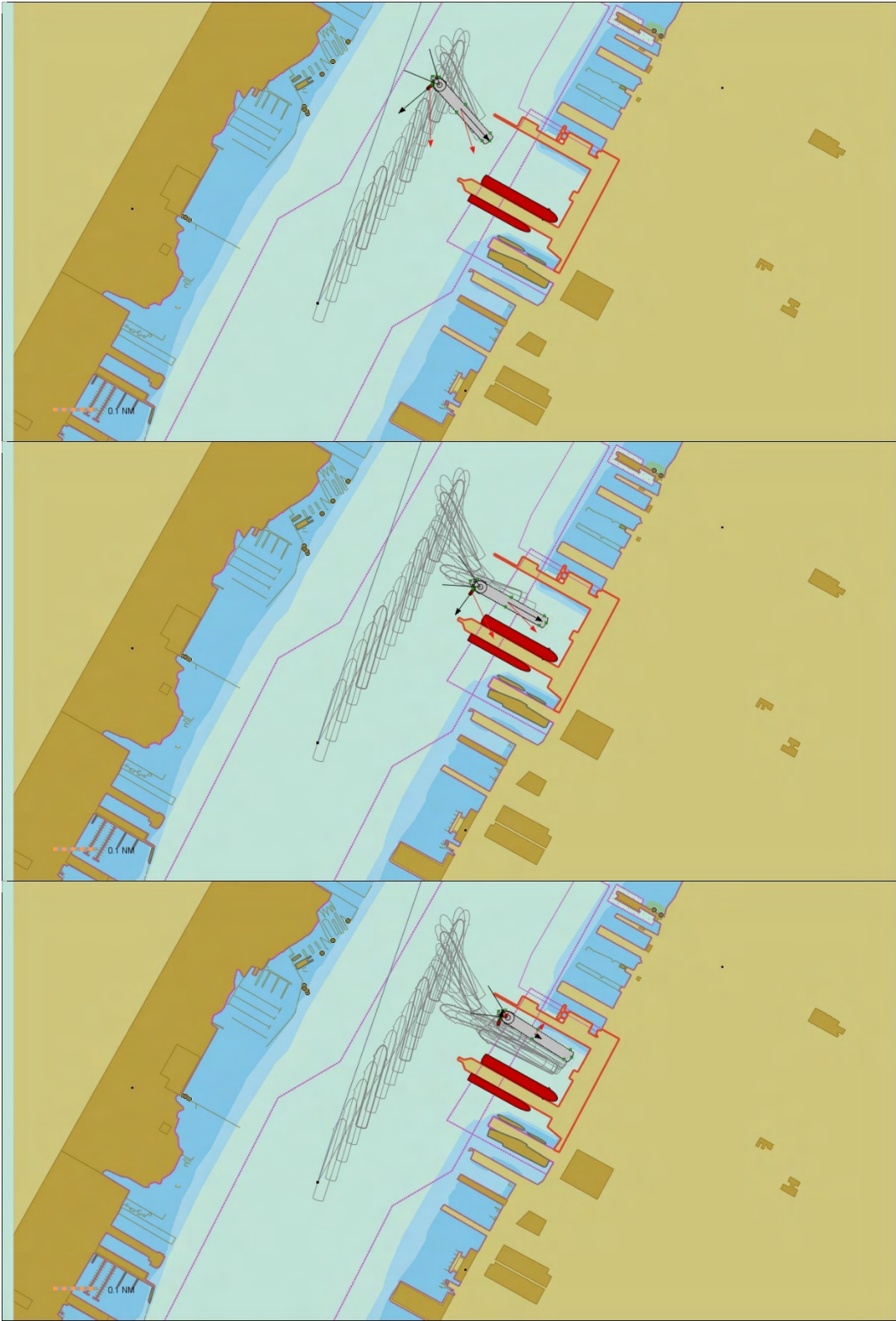
The ship had sufficient resources to berth successfully and in a controlled manner. The entire berthing operation took 46 minutes until the ship was in a safe position to send out mooring lines. Tug assistance and power was not used during the run.

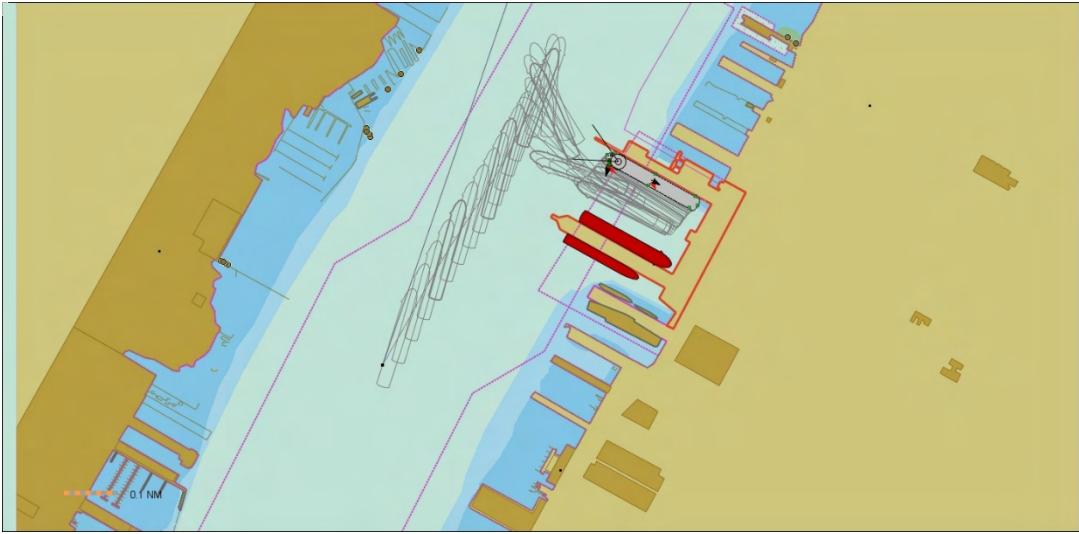
The maneuver required constant attention and alertness to control the ship's transverse and lateral speed and have exact awareness and positioning of the ship's stern. The ship-handling maneuver was graded as MODERATE.

The completion status of the simulation run was graded as SUCCESSFUL.

Select snapshots of the run simulation are provided in the images below at key points through the maneuver.







## Run 6

Berth	92S	Route/Duration	Arrival / 37 mins
Maneuver	IN Bow First	Alongside	Port
Current	Ebb x 2.5 kts.	Wind	(NE) 045° x 15kt
Maneuver Grade	Moderate	Completion Status	Marginal
AziPod 0 (Stbd)	64%	Bow Tr.Pair No.1	100%
AziPod 1 (Port)	64%	Bow Tr.Pair No.2	100%

**Comment:**

The ship starts at approximately 0.4 nautical miles southwest of Pier 88, inbound for Pier 92S with a bow-in, port-side-alongside approach. One tug was secured to the starboard shoulder near the bow.

Initially, the ship was making a heading of 030° at 3.5 knots with a small drift angle due to a frontal north-easterly wind and current. Speed was gradually reduced to about 2.5 knot. A starboard swing was initiated when the ship's bow was in line with end tip of Pier 92. The bow and stern swing were controlled to steer the ship into the MCT pier basin.

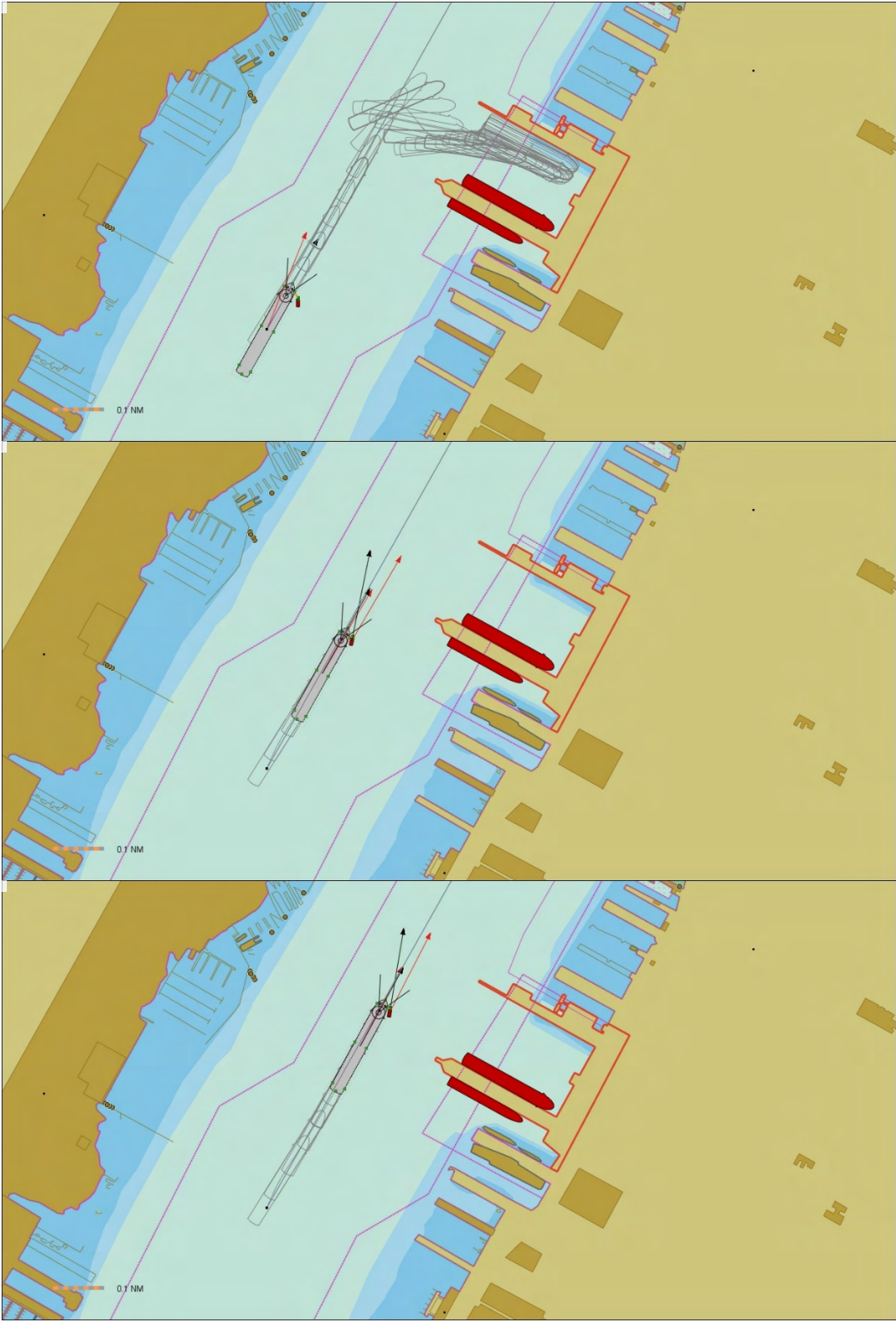
When the ship's heading was perpendicular to the ebb current, and the north-easterly wind was blowing broadside on the same side, additional power assistance was required from the forward tug, together with 100% power on the bow thrusters, to maintain bow control. The maximum tug power used was 75%. The ship's forward speed and the rate of turn were continuously checked. Control improved as the ship moved further into the MCT pier basin and away from the influence of the ebb current.

The ship had sufficient resources to berth successfully and in a controlled manner. The entire berthing operation took 37 minutes until the ship was in a safe position to send out mooring lines.

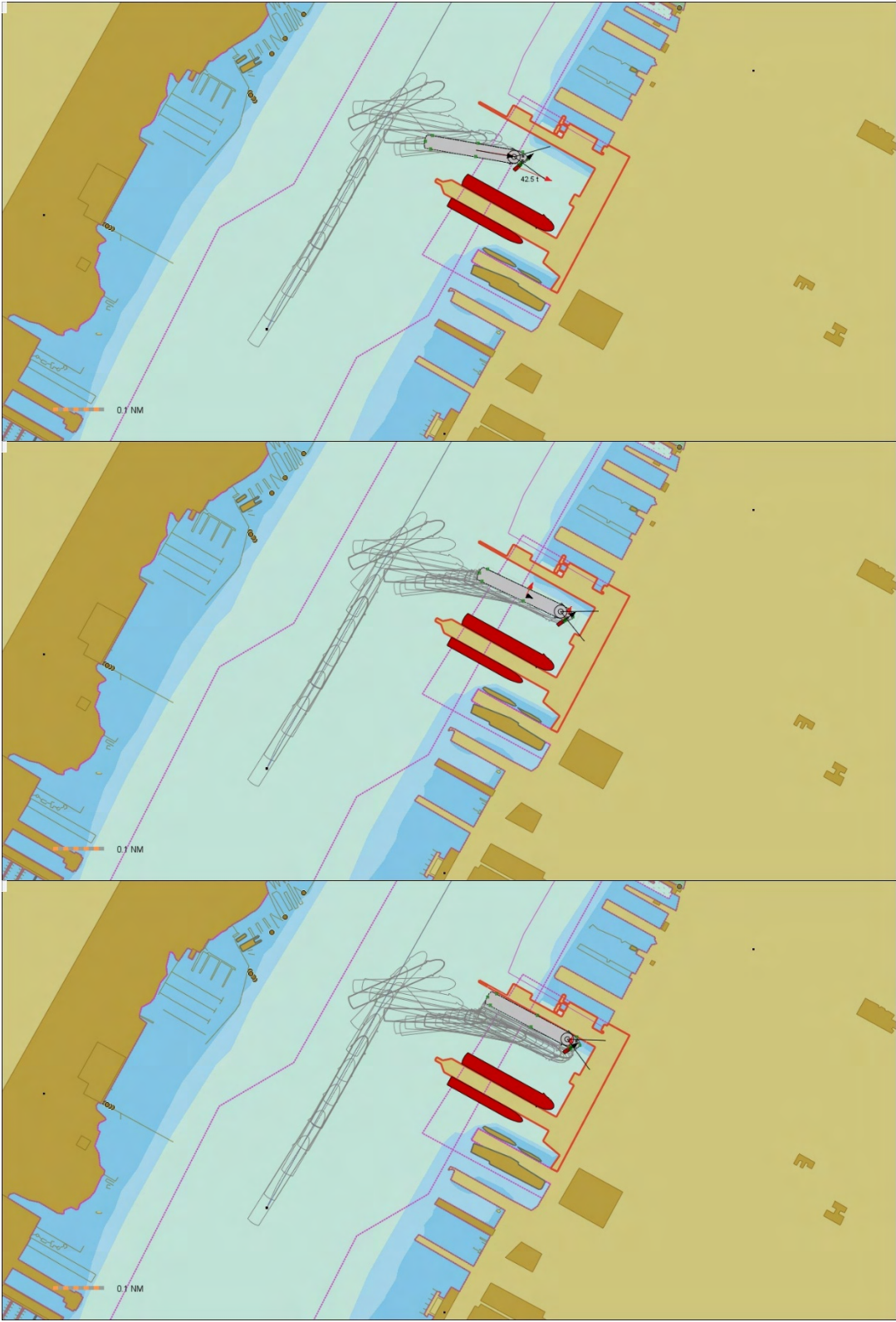
The maneuver required constant attention and alertness to control the ship's transverse and lateral speed. The ship-handling maneuver was graded as MODERATE.

The completion status of the simulation run was graded as MARGINAL because maximum bow thruster power was required continuously or for a prolonged period during the maneuver together with the required assistance of a tug.

Select snapshots of the run simulation are provided in the images below at key points through the maneuver.







## Run 7

Berth	92S	Route/Duration	Arrival / 28 mins
Maneuver	IN Bow First	Alongside	Port
Current	Flood x 2.0 kts.	Wind	(NW) 315° x 25kt
Maneuver Grade	Easy	Completion Status	Successful
AziPod 0 (Stbd)	80%	Bow Tr.Pair No.1	55%
AziPod 1 (Port)	67%	Bow Tr.Pair No.2	60%

**Comment:**

The ship starts at approximately 0.4 nautical miles southwest of Pier 88, inbound for Pier 92S with a bow-in, port-side-alongside approach. One tug was secured to the starboard shoulder near the bow.

Initially, the ship was making a heading of 017° at 3.5 knots with a drift angle of approximately 020° to starboard due to a strong north-westerly wind and tidal current at ship's quarter.

When the ship's bow was in line with end tip of Pier 88, starboard swing was initiated to enter the MCT pier basin. The ship speed was also reduced quickly. Bow thrusters were used to assist in the swing.

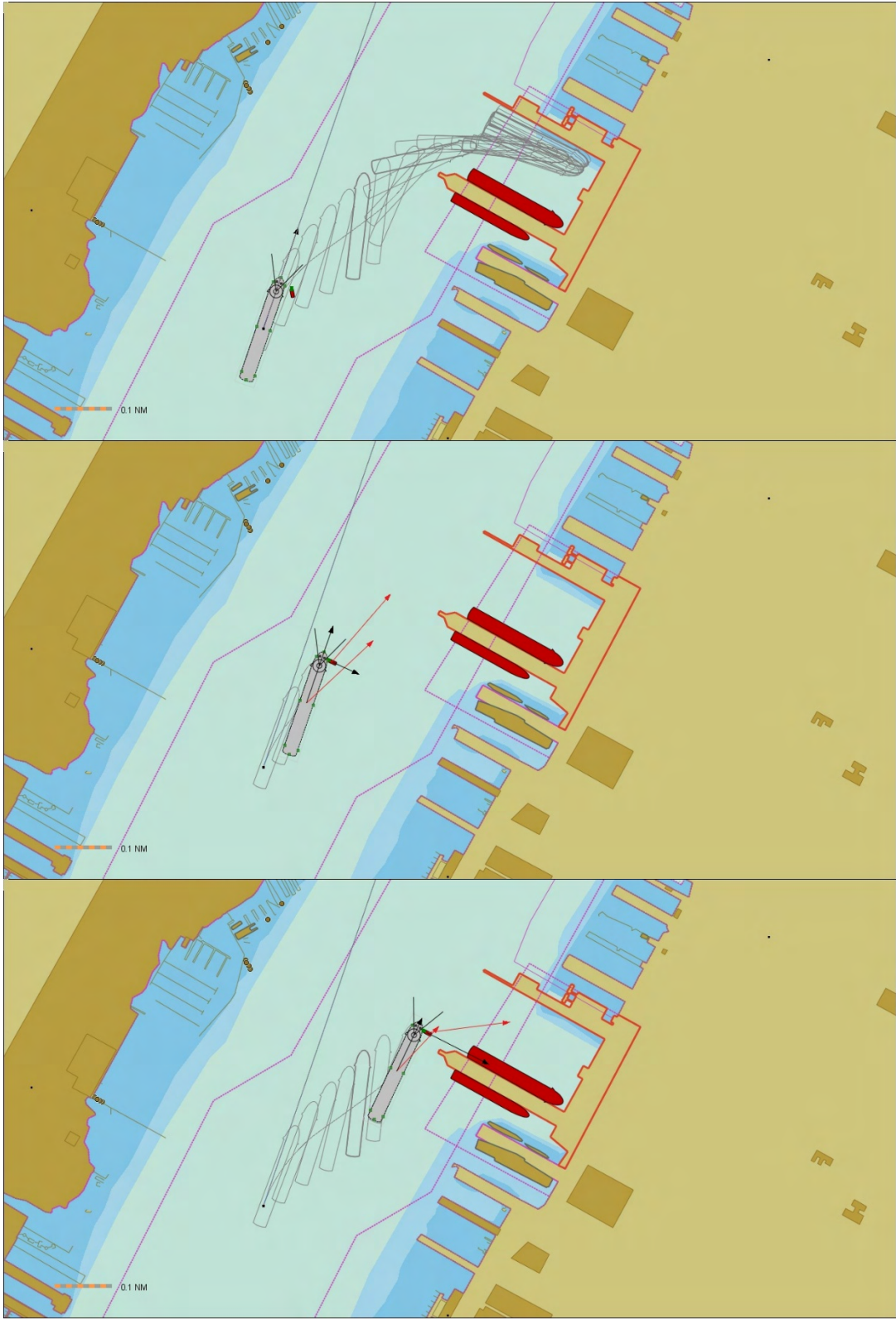
The bow and stern swing were controlled to steer the ship into the MCT pier basin. Both forward speed and the rate of turn were continuously checked. Control improved as the ship moved further into the MCT pier basin and away from the influence of tidal current.

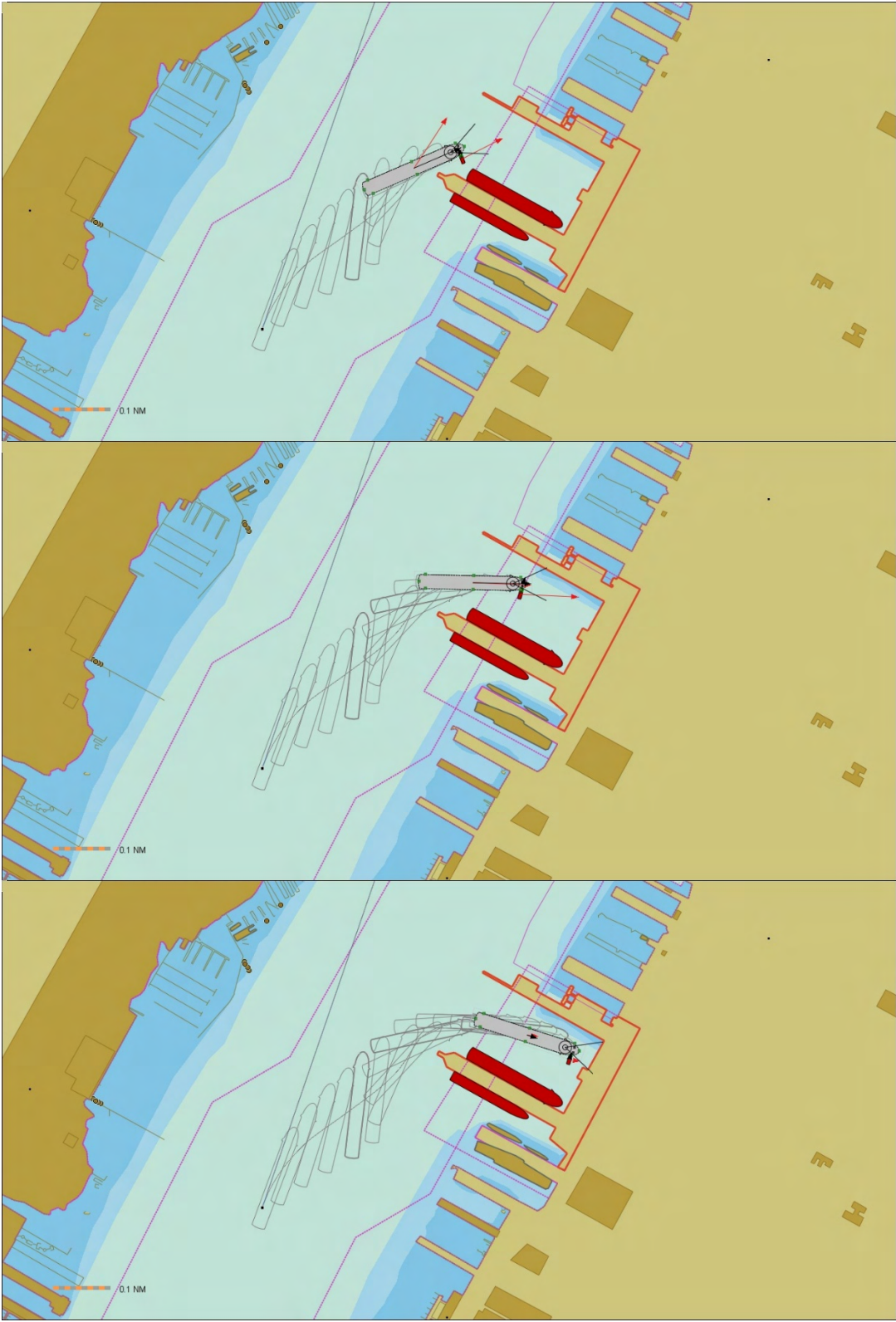
The ship had sufficient resources to berth successfully and in a controlled manner. The entire berthing operation took 28 minutes until the ship was in a safe position to send out mooring lines.

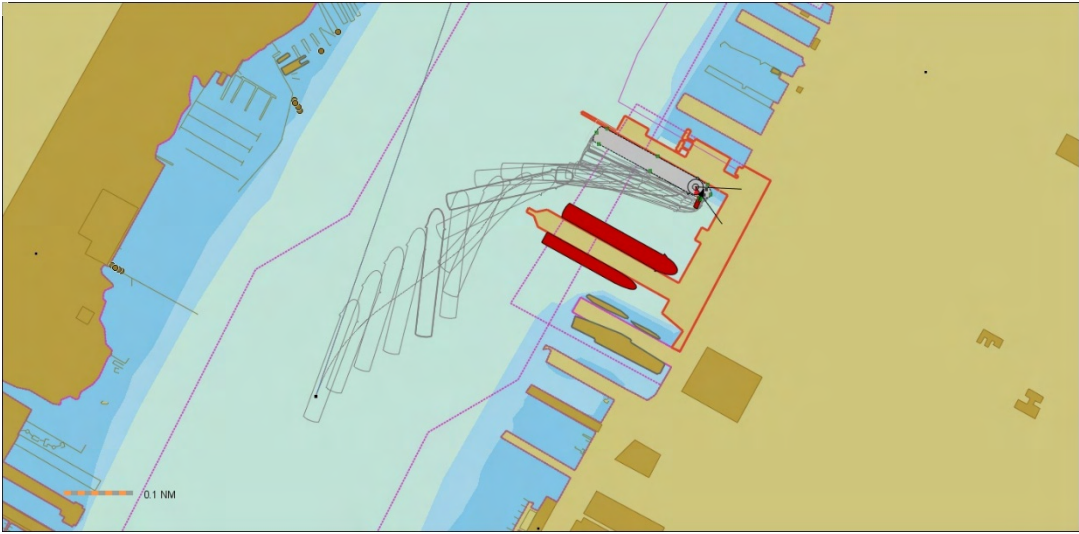
The ship-handling maneuver was graded as EASY.

The completion status of the simulation run was graded as SUCCESSFUL.

Select snapshots of the run simulation are provided in the images below at key points through the maneuver.







## Run 8

Berth	92S	Route/Duration	Depart / 18 mins
Maneuver	Back out-Stern first	Alongside	Port
Current	Flood x 2.0 kts.	Wind	(NW) 315° x 25kt
Maneuver Grade	Easy	Completion Status	Successful
AziPod 0 (Stbd)	73%	Bow Tr.Pair No.1	79%
AziPod 1 (Port)	73%	Bow Tr.Pair No.2	80%

**Comment:**

The ship started docked port side alongside Pier 92S.

Slow power on the AziPod stern thrusters and bow thrusters was used to pull the ship parallel off the pier.

Once the ship had cleared the berth by approximately one beam width, astern power was applied to back the ship out, stern first, at a controlled speed to exit the MCT pier basin as quickly as possible.

When the ship's bow cleared the end tip of Pier 88, the bow thrusters and stern thrusters were used to swing the ship to starboard while still moving astern.

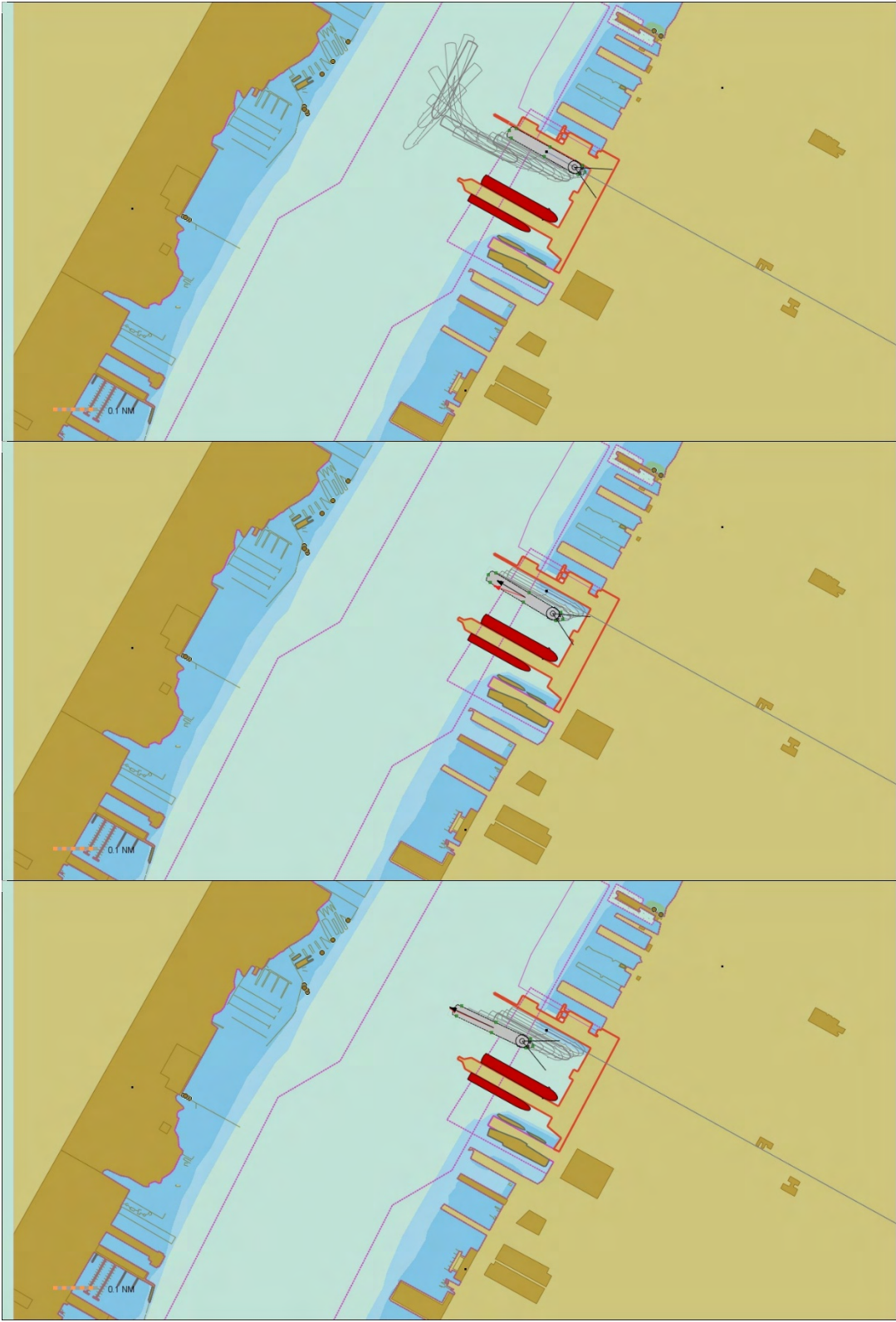
The ship's rate of turn and speed were monitored to align the bow for an outbound heading toward the southwest, taking into consideration the drift angle caused by wind and tidal current. The ship was then put ahead to steer out on its own power.

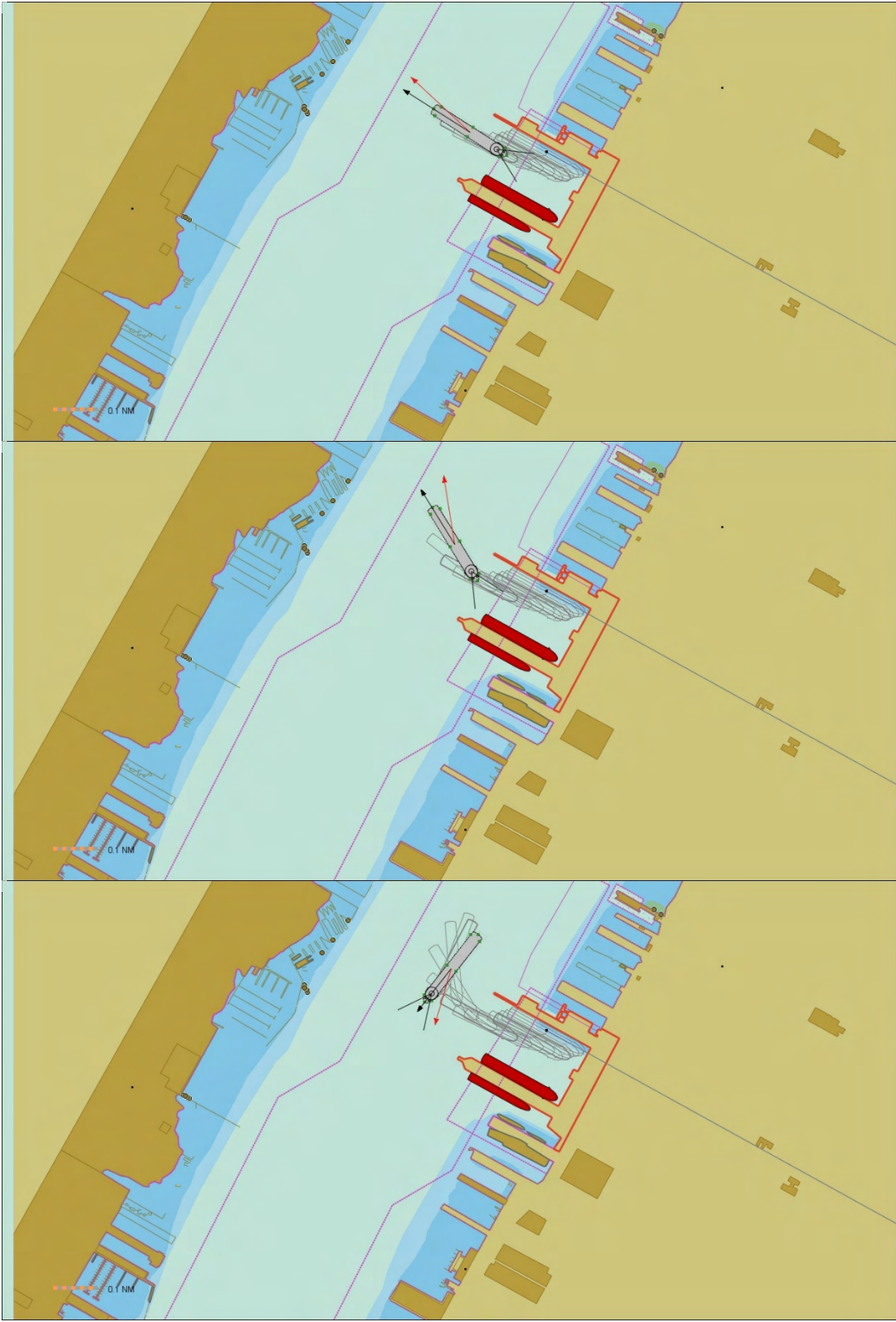
The ship had sufficient resources to unberth and maneuver outbound in a controlled manner, and there were no significant concerns during the operation. The entire run took 18 minutes until the ship reached a safe outbound position. The run was comfortable.

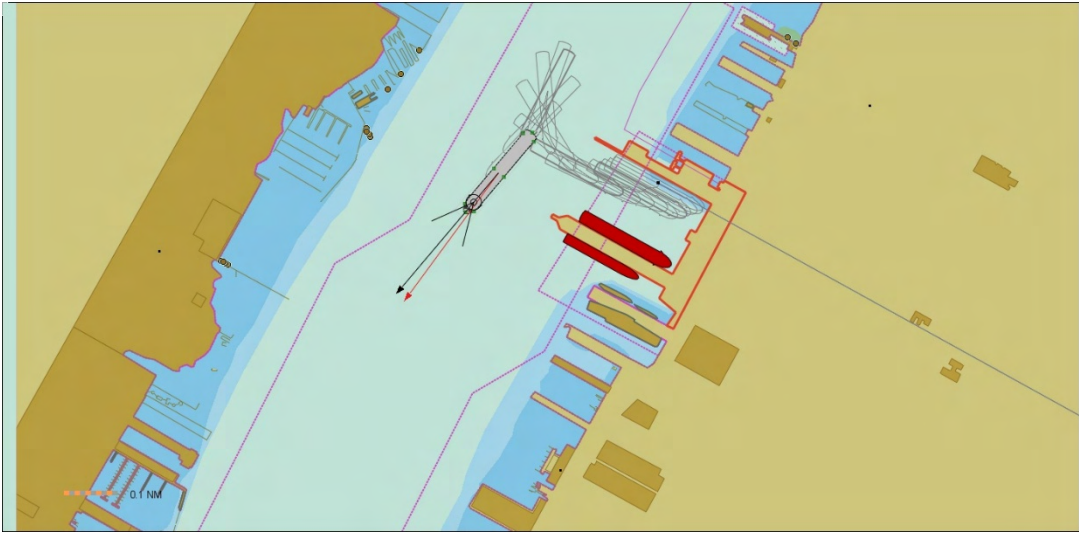
The ship-handling maneuver was graded as EASY.

The completion status of the simulation run was graded as SUCCESSFUL.

Select snapshots of the run simulation are provided in the images below at key points through the maneuver.







## Run 9

Berth	88N	Route/Duration	Arrival / 28 mins
Maneuver	IN Bow First	Alongside	Starboard
Current	Flood x 2.0 kts.	Wind	(SW) 225° x 25 kts.
Maneuver Grade	Moderate	Completion Status	Marginal
AziPod 0 (Stbd)	73%	Bow Tr.Pair No.1	100%
AziPod 1 (Port)	80%	Bow Tr.Pair No.2	100%

**Comment:**

The ship starts at approximately 0.4 nautical miles southwest of Pier 88, inbound for Pier 88N with a bow-in, starboard-side-alongside approach. One tug was secured to the port shoulder near the bow.

Initially, the ship was making a heading of 019° at 3.5 knots with a small drift angle due to an aft south-westerly wind and current. An early starboard swing was initiated when the ship's bow was in line with the Intrepid Museum. The bow and stern swing were controlled to steer the ship into the MCT pier basin. Speed was gradually reduced to about 2.0 knot.

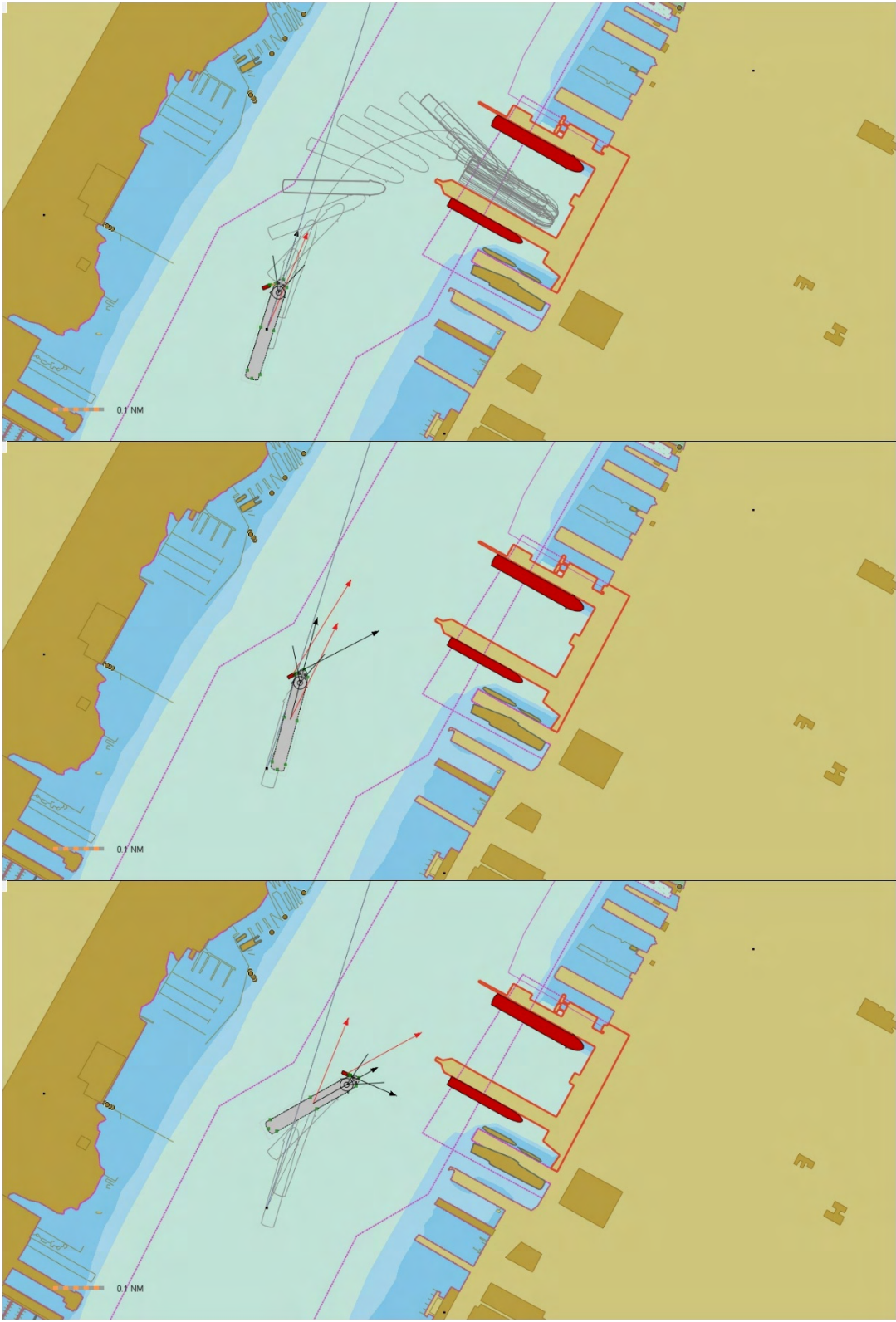
When the ship's heading was perpendicular to the flood current, and the south-westerly wind was blowing broadside on the same side, additional power assistance was required from the forward tug, together with 100% power on the bow thrusters, to maintain bow control. The maximum tug power used was 75%. The ship's forward speed and the rate of turn were continuously checked. Control improved as the ship moved further into the MCT pier basin and away from the influence of the flood current.

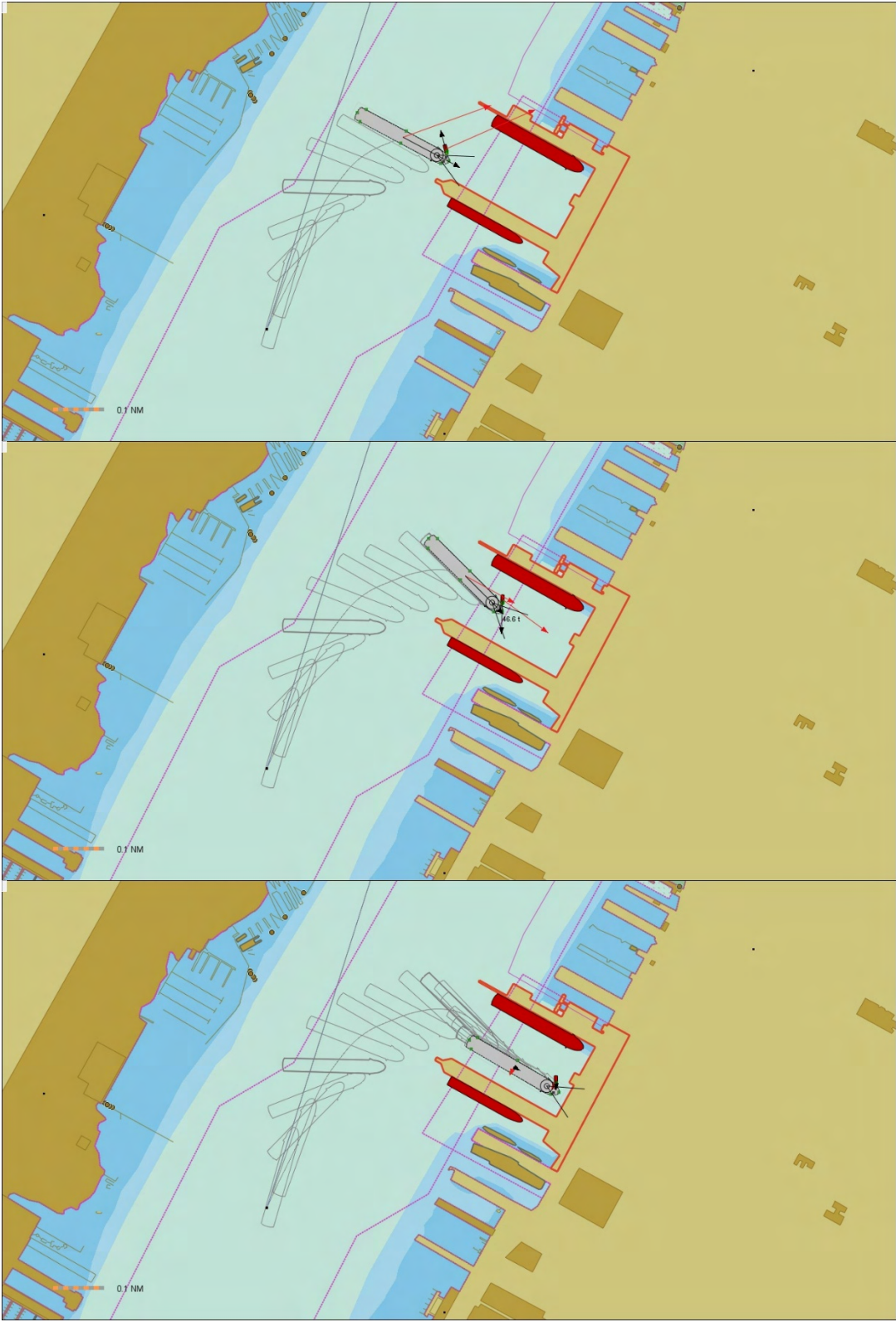
The ship had sufficient resources to berth successfully and in a controlled manner. The entire berthing operation took 28 minutes until the ship was in a safe position to send out mooring lines.

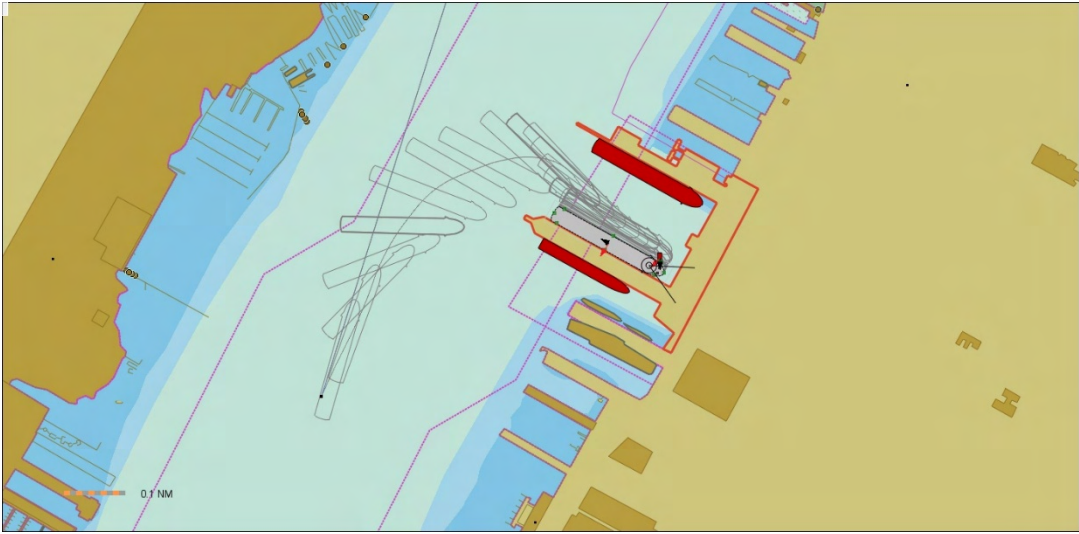
The maneuver required constant attention and alertness to control the ship's transverse and lateral speed. The ship-handling maneuver was graded as MODERATE.

The completion status of the simulation run was graded as MARGINAL because maximum bow thruster power was required continuously or for a prolonged period during the maneuver together with the required assistance of a tug.

Select snapshots of the run simulation are provided in the images below at key points through the maneuver.







## Run 10

Berth	88N	Route/Duration	Depart / 16 mins
Maneuver	Back out-Stern first	Alongside	Starboard
Current	Flood x 2.0 kts.	Wind	(SW) 225° x 25 kts.
Maneuver Grade	Easy	Completion Status	Successful
AziPod 0 (Stbd)	66%	Bow Tr.Pair No.1	68%
AziPod 1 (Port)	94%	Bow Tr.Pair No.2	74%

**Comment:**

The ship started docked starboard side alongside Pier 88N.

Slow power on the AziPod stern thrusters and bow thrusters was used to pull the ship parallel off the pier.

Once the ship had cleared the berth by approximately one beam width, astern power was applied to back the ship out, stern first, at a controlled speed to exit the MCT pier basin as quickly as possible.

When the ship's bow cleared the end tip of Pier 88, the bow thrusters and stern thrusters were used to swing the ship to starboard while still moving astern.

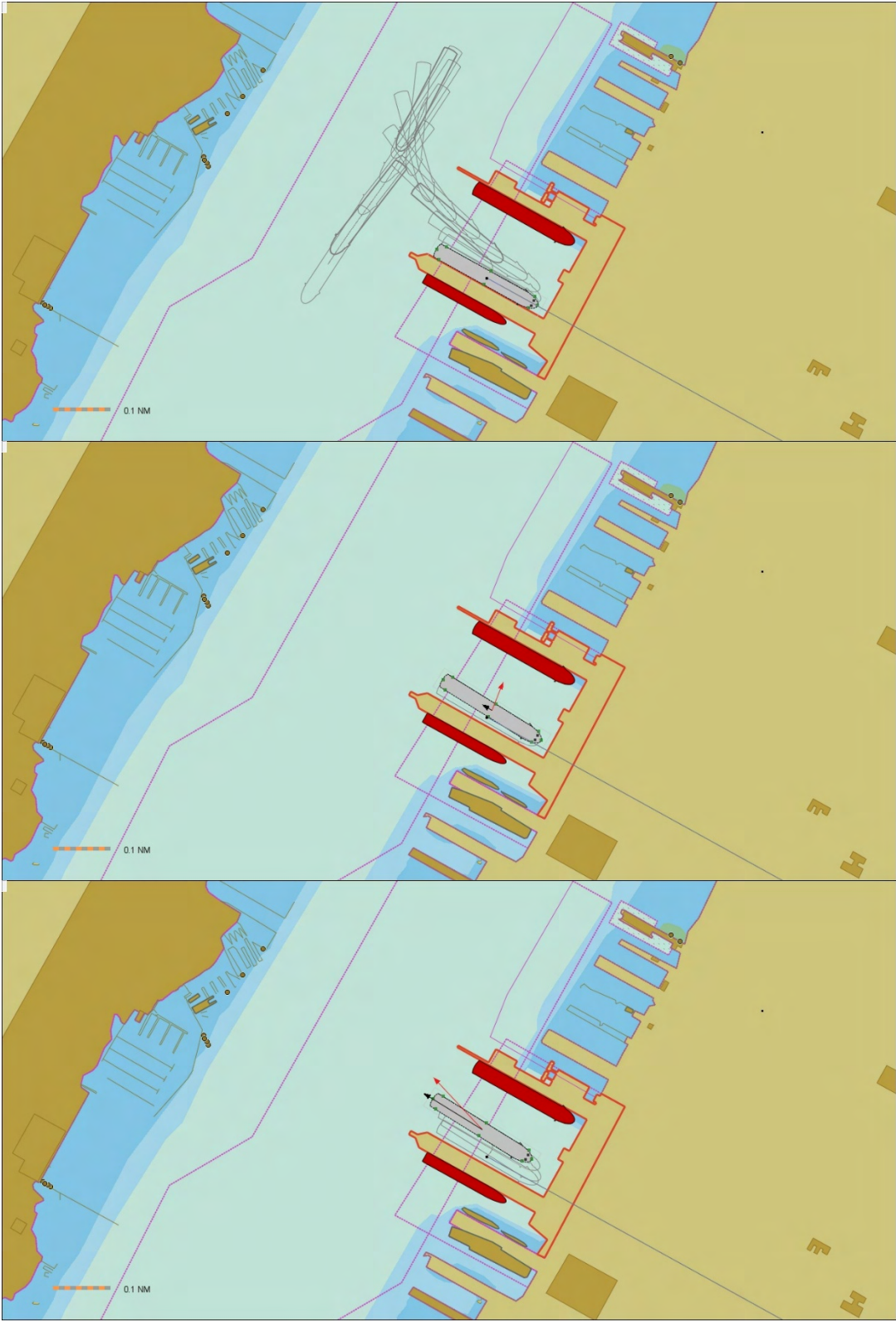
The ship's rate of turn and speed were monitored to align the bow for an outbound heading toward the southwest, taking into consideration the drift angle caused by wind and tidal current. The ship was then put ahead to steer out on its own power.

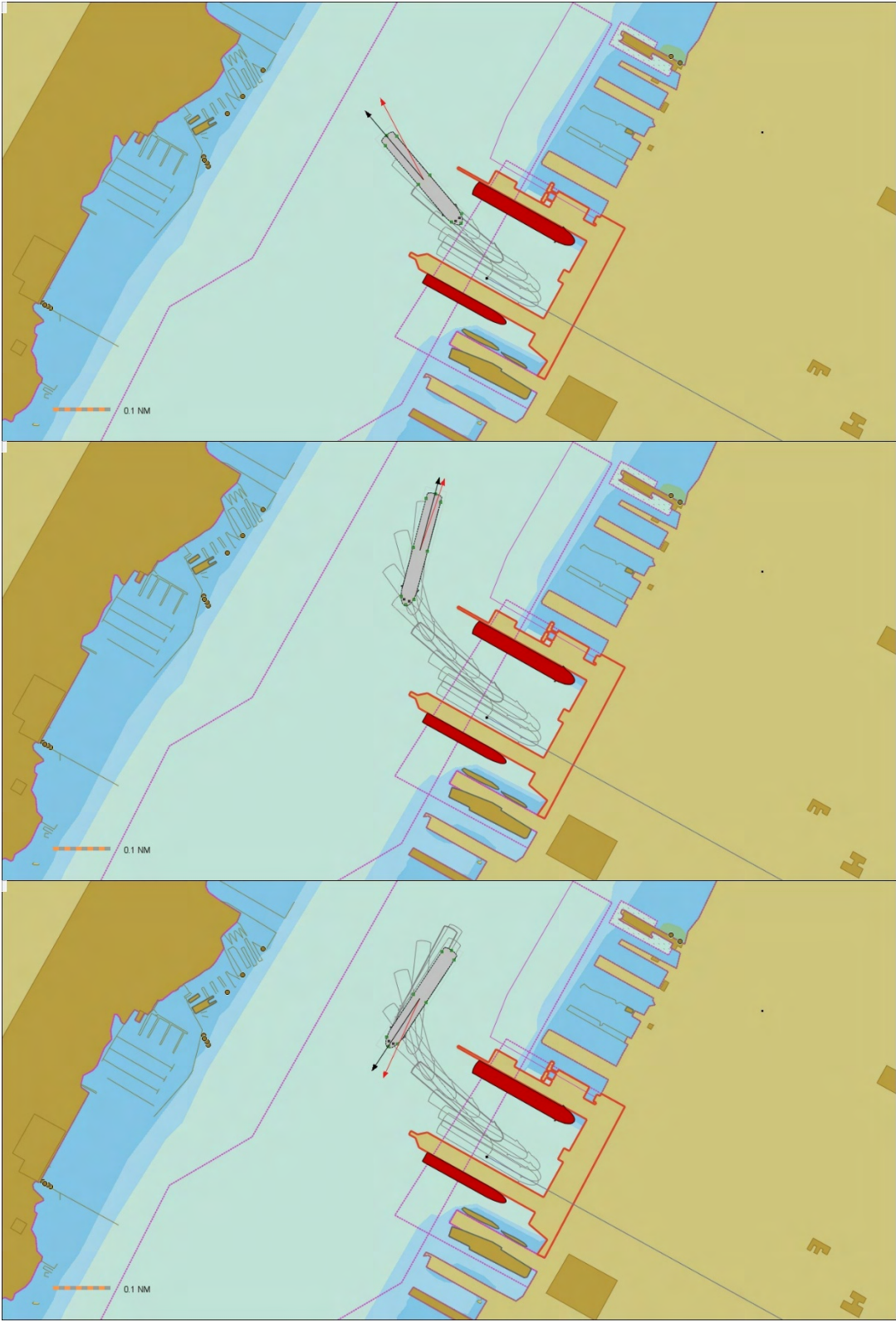
The ship had sufficient resources to unberth and maneuver outbound in a controlled manner, and there were no significant concerns during the operation. The entire run took 16 minutes until the ship reached a safe outbound position. The run was comfortable.

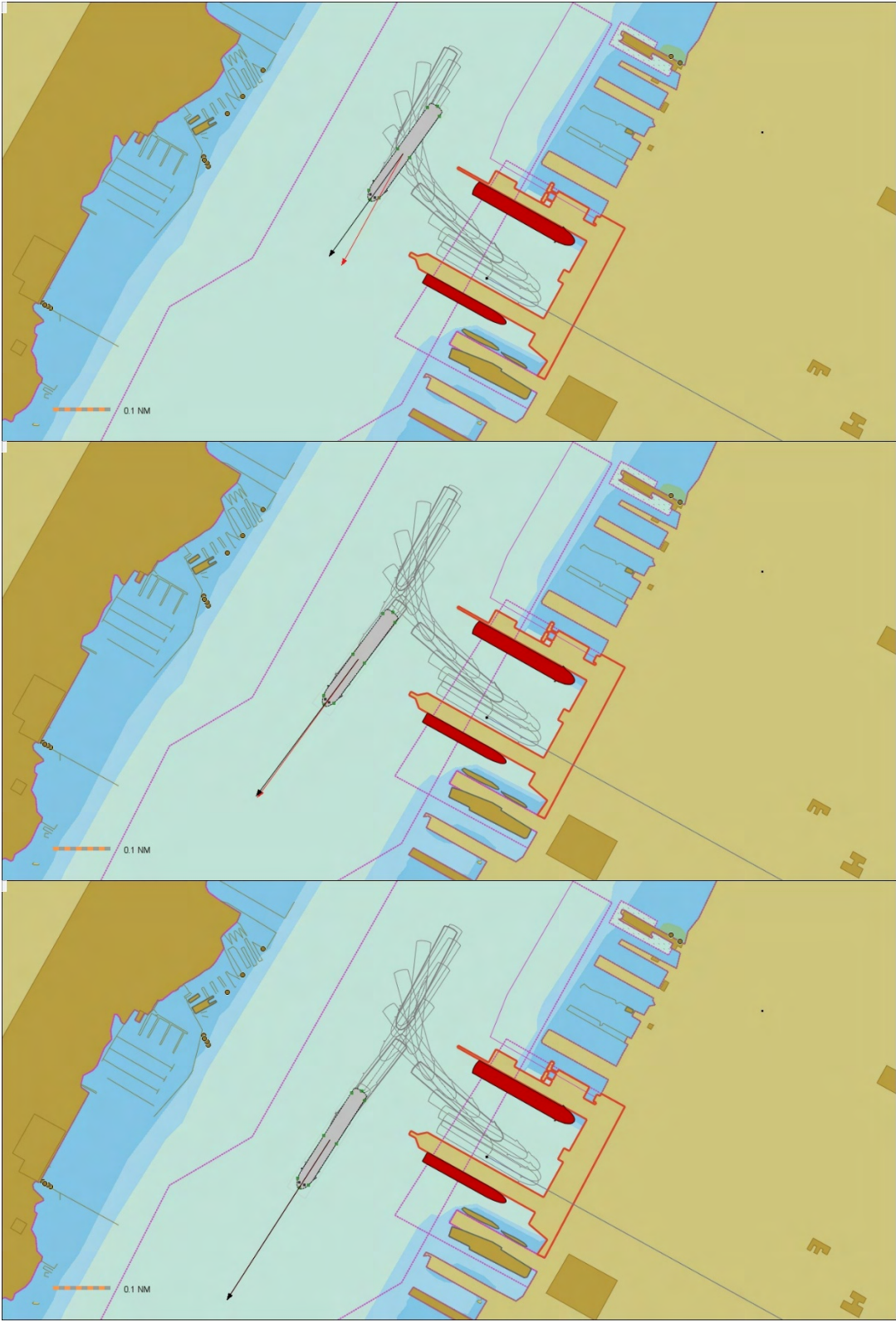
The ship-handling maneuver was graded as EASY.

The completion status of the simulation run was graded as SUCCESSFUL.

Select snapshots of the run simulation are provided in the images below at key points through the maneuver.







## Run 11

Berth	92S	Route/Duration	Arrival / 42 mins
Maneuver	IN Bow First	Alongside	Port
Current	Ebb x 2.5 kts.	Wind	NW x 25 kts. + 35kts gust
Maneuver Grade	Difficult	Completion Status	Marginal
AziPod 0 (Stbd)	100%	Bow Tr.Pair No.1	100%
AziPod 1 (Port)	100%	Bow Tr.Pair No.2	100%

**Comment:**

The ship starts at approximately 0.4 nautical miles southwest of Pier 88, inbound for Pier 92S with a bow-in, port-side-alongside approach. One tug was secured to the starboard shoulder near the bow. Wind speed was 25 knots blow from Northwest.

Initially, the ship was making a heading of 019° at 3.5 knots. Speed was gradually reduced to about 2 knots while monitoring the ship's heading and the increasing drift angle.

A starboard swing was initiated when the ship's bow was in line with Pier 92S. At this time the wind picks up to 35 knots. The bow and stern swing were controlled to steer the ship into the MCT pier basin. Both forward speed and the rate of turn were continuously checked.

As the ship swung and its heading neared perpendicular to the ebb current, the 35-knot north-westerly wind blew broadside on the same side. This force combination required 100% power on the bow thrusters and 100% power on the Azipod stern thrusters for control, together with additional assistance from the forward tug (which reached a maximum use of 75% power).

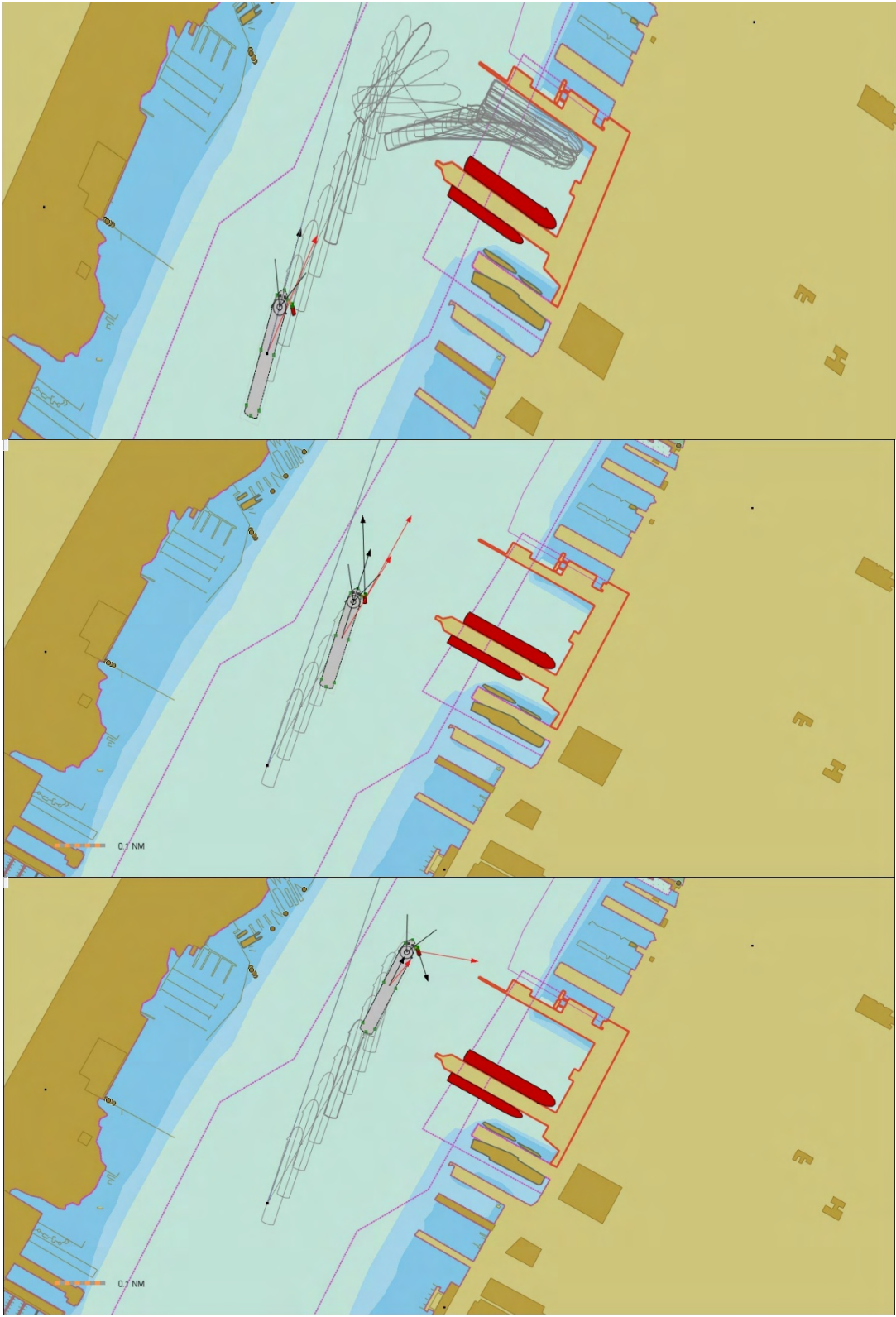
The ship's forward speed and the rate of turn were continuously checked. Control improved as the ship moved further into the MCT pier basin and away from the influence of the ebb current.

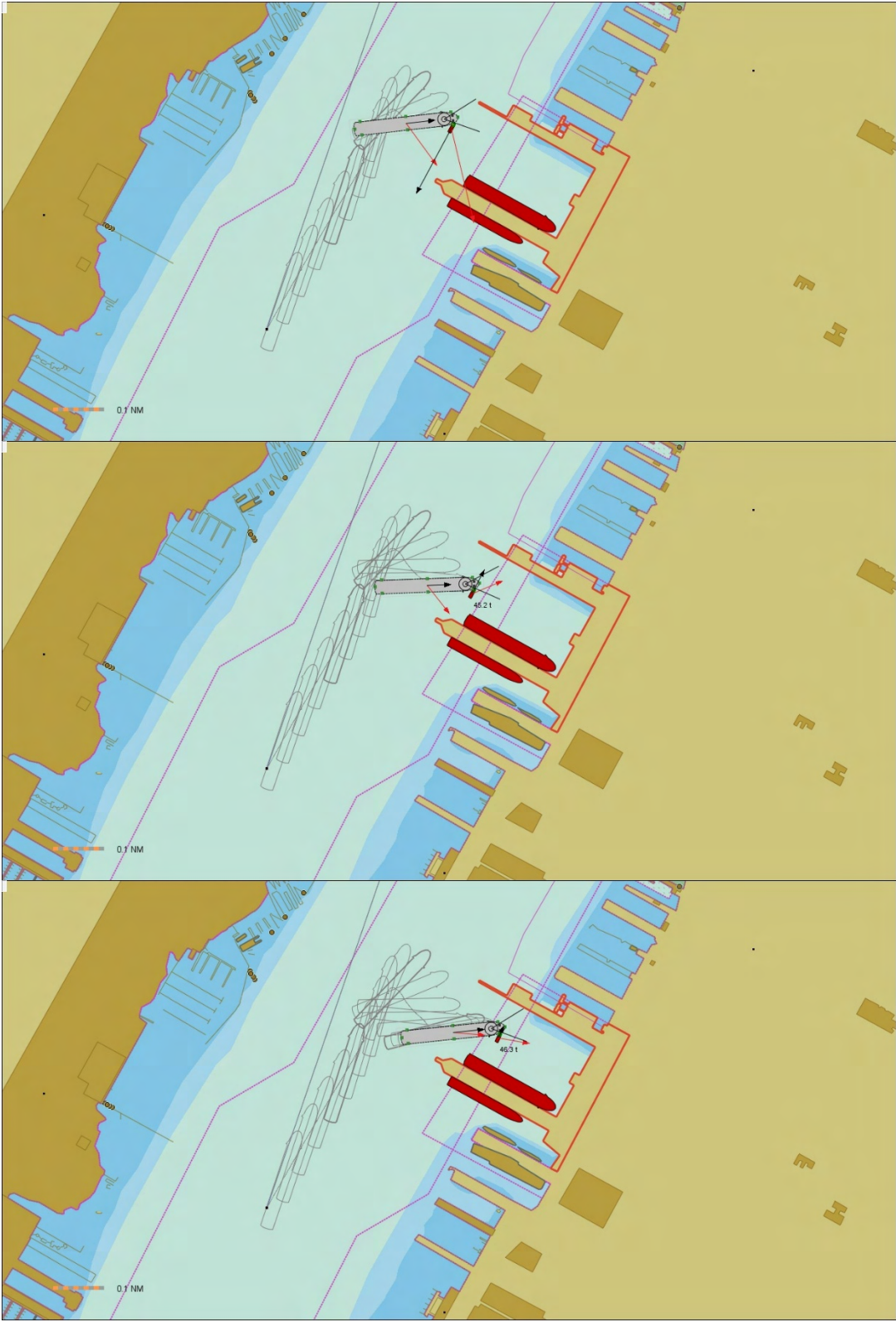
Inside the MCT pier basin, with the wind speed still at 35 knots, the ship had sufficient resources to berth successfully in a controlled manner. The entire berthing operation took 42 minutes until the ship was in a safe position to send out mooring lines.

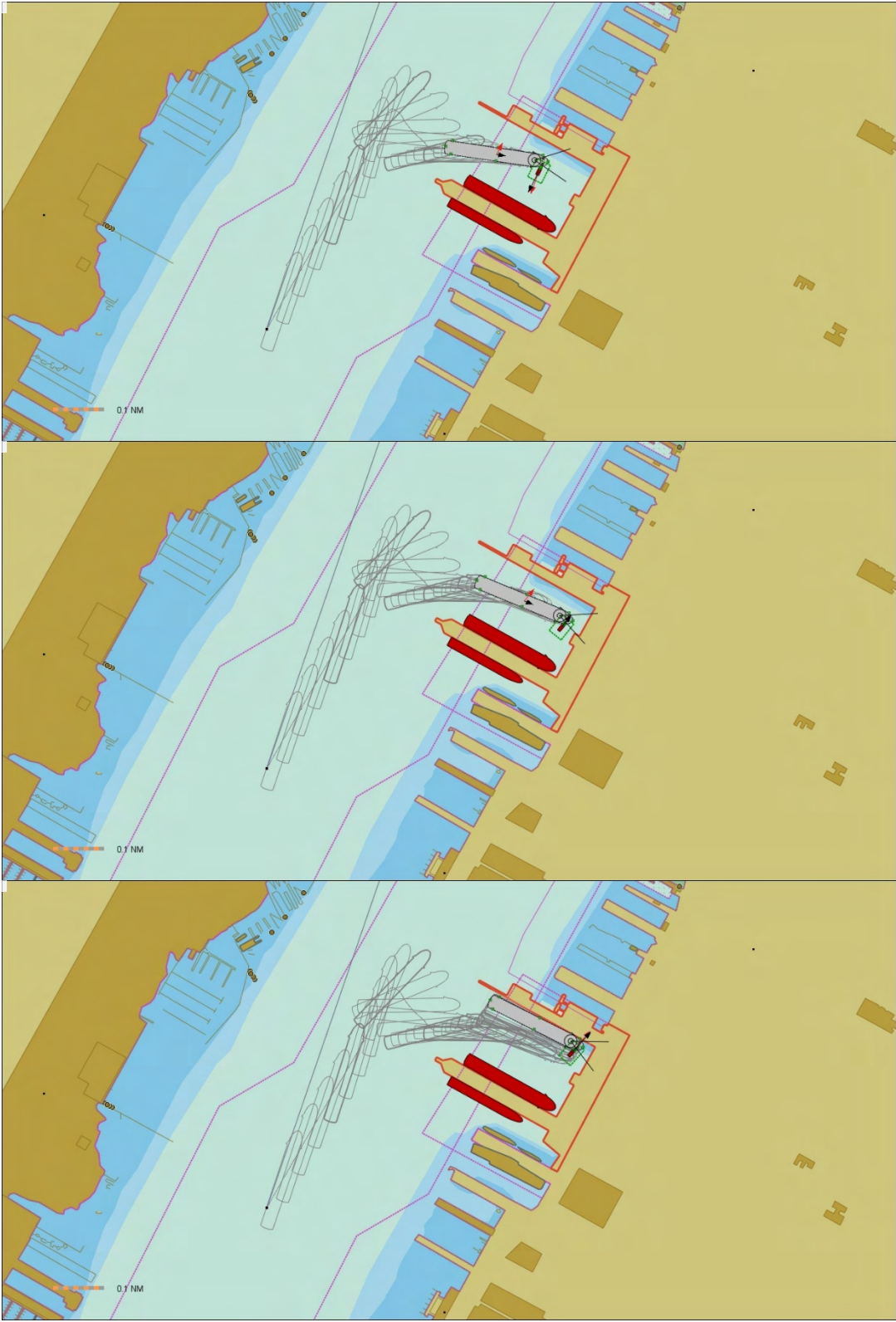
The maneuver required constant attention and alertness to control the ship's transverse and lateral speed. The ship-handling maneuver was graded as DIFFICULT.

The completion status of the simulation run was graded as MARGINAL because maximum power on the Azipod stern thruster and bow thrusters was needed for control, together with additional assistance from the forward tug.

Select snapshots of the run simulation are provided in the images below at key points through the maneuver.







## Run 12

Berth	92S	Route/Duration	Depart / 15 mins
Maneuver	Back out-Stern first	Alongside	Port
Current	Ebb x 2.5 kts.	Wind	NW x 25 kts. + 35kts gust
Maneuver Grade	Difficult	Completion Status	Marginal
AziPod 0 (Stbd)	100%	Bow Tr.Pair No.1	100%
AziPod 1 (Port)	100%	Bow Tr.Pair No.2	100%

**Comment:**

The ship started docked port side alongside Pier 92S.

Slow power on the AziPod stern thrusters and bow thrusters was used to pull the ship parallel off the pier. When the ship had cleared the berth by approximately half beam width, the north-westerly wind picks up speed from 25 knots to 35 knots.

Astern power was applied to back the ship out, stern first, at a controlled speed to exit the MCT pier basin as quickly as possible. As the ship's stern enters the Hudson River, the ebb current and wind pushes the stern southward.

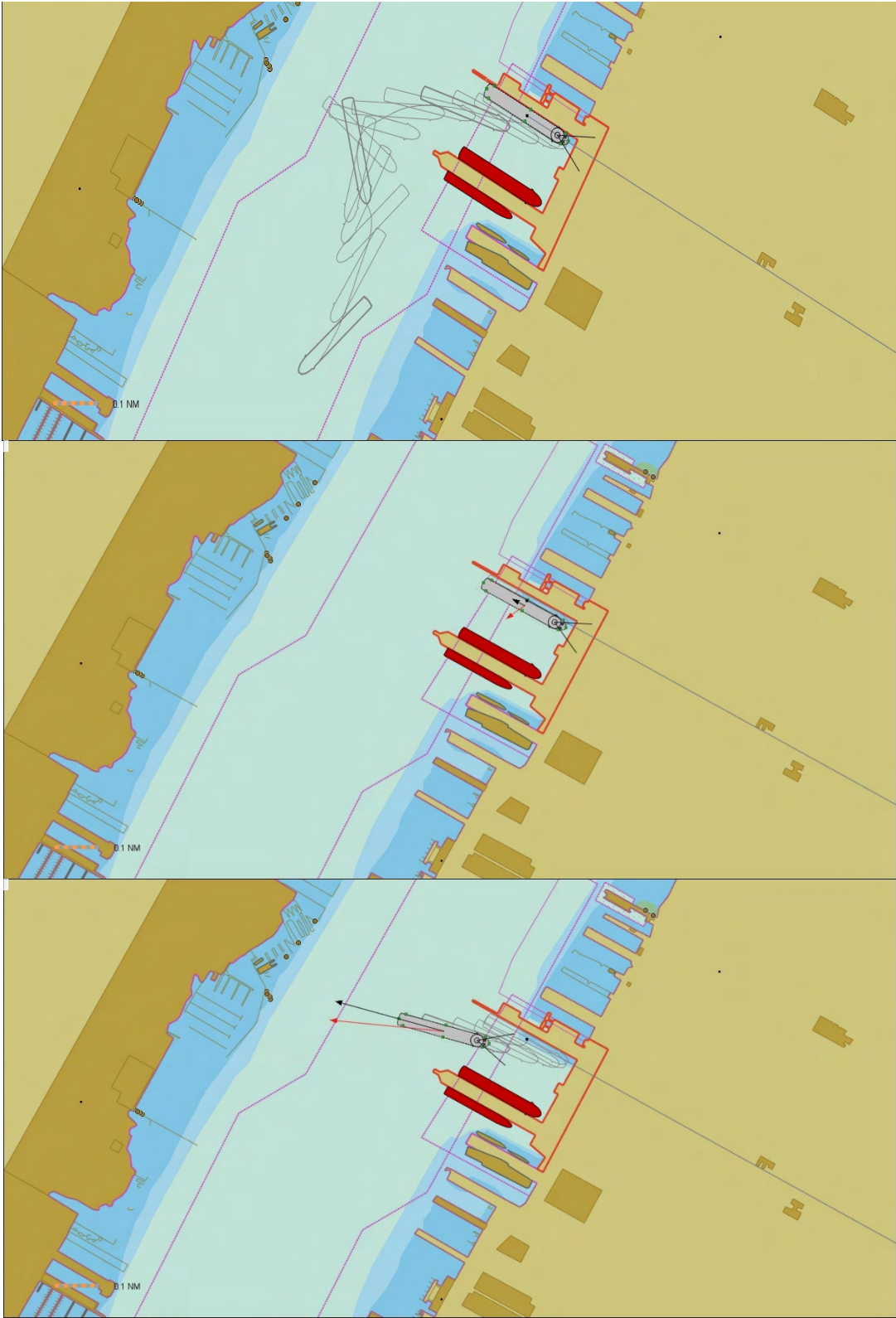
When the ship's bow cleared the end tip of Pier 88, the bow thrusters and stern thrusters were used to swing the ship to starboard and start going ahead. The ship's rate of turn and speed were monitored to align the bow for an outbound heading toward the southwest.

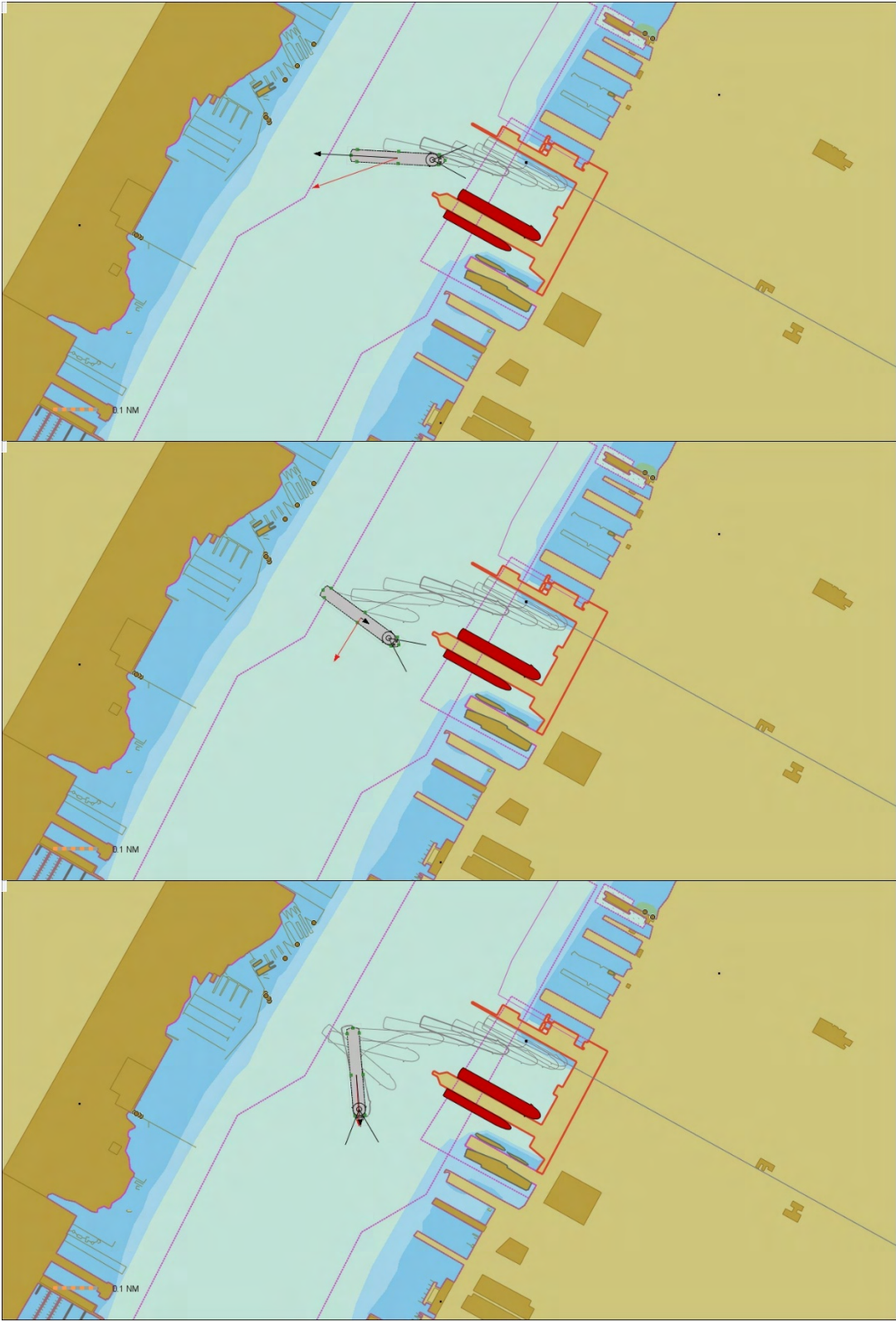
The ship erred and overswung, causing the ebb current to act on the starboard quarter while a 35-knot north-westerly wind blew broadside on the same side. This force combination required 100% power on the bow thrusters and 100% power on the AziPod stern thrusters to control the large drift angle to port. As the ship speed picks up, the drift angle was managed and the ship steered out on its own power. The entire run took 15 minutes until the ship reached a safe outbound position

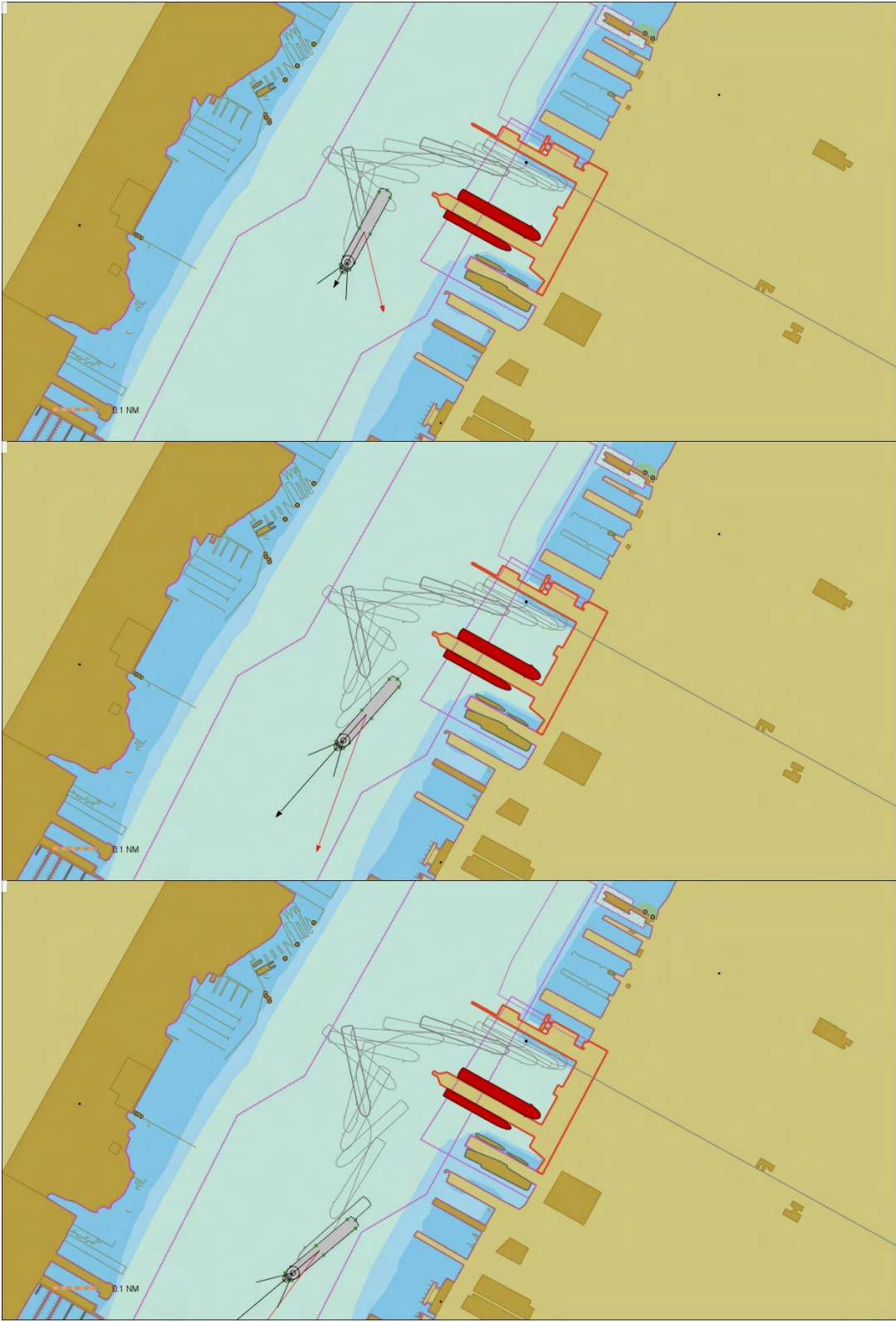
The maneuver required constant attention and alertness to control the ship's transverse and lateral speed and large drift angle. The ship-handling maneuver was graded as DIFFICULT.

The completion status of the simulation run was graded as MARGINAL because maximum power on the AziPod stern thruster and bow thrusters was required for a prolonged period during the maneuver.

Select snapshots of the run simulation are provided in the images below at key points through the maneuver.







# **Appendix K: DHI's SIREN Model**

## Overview

DHI's SIREN model is a navigational risk modelling framework that is built on-top of DHI's ABM Lab. This is a general-purpose agent-based modelling framework that has been customized and adapted to navigational risk. SIREN performs agent-based simulations to model vessel movements and behavior in realistic environmental and operational conditions. SIREN is fully and seamlessly integrated with the broader MIKE Powered by DHI modelling suite, which allows for high-resolution hydrodynamic and environmental inputs to be incorporated directly into the vessel movement and risk modelling.

The SIREN modelling approach simulates each vessel as individual agents that are following data driven movement patterns and statistics derived from underlying AIS data. As well, users can add traffic rules, alter historical patterns, generate synthetic data (e.g. future cruise ship traffic) and assess various "what-if" scenarios.

This system can also integrate high resolution, potentially dynamic, bathymetry for accurate grounding assessments and also incorporates both fixed and floating and/or drifting structures that may be influenced by environmental forcing (e.g. extended piers).

SIREN follows standard empirical risk calculation methodologies found in literature and has been benchmarked in idealized scenarios against literature and other common navigational risk modelling frameworks. However, the unique and inherent nature of the agent-based modelling approach leads to a detailed spatiotemporally varying risk assessment that can provide insight into risk patterns both spatially and over time that is not possible in other approaches.

Detailed information about location, timing, static and dynamic vessel characteristics of risk indices can be extracted from the model outputs providing detailed insight into navigational risk in the study area for mitigation measure development or planning purposes.

Furthermore, the unique unstructured graph approach (detailed below) allows for flexible, robust, and rapid model generation for both offshore areas and inland waterways, with traffic conditions ranging from random and sparse to well defined and regular. This ensures an accurate representation and assessment of all forms of vessel traffic that is not possible (or at least easily achieved) in other navigational risk modelling software, where sparse traffic is often omitted completely, or highly simplified for incorporation into risk estimates.

The SIREN model consists of 6 distinct steps:

- Data Pre-processing
- Model Generation
- Traffic Rules, Inputs, and Environmental Integration
- Model Execution
- Risk Calculation
- Post-Processing and Output Analysis

## Data Pre-processing

The general starting point of a SIREN model is taking historical AIS data and using it to generate a representative traffic model of the Study Area which can be used to assess risk and/or evaluate what-if scenarios. The first step of this process is to ingest, quality control, and pre-process the AIS data to prepare it for modelling and to extract key statistics that will be used to drive the model.

To do this, the SIREN model is integrated with DHI's free and open-source AIS processing framework *trackio* (available freely and public on GitHub). This framework is used to perform a standard battery of quality control operations on the AIS data such as:

- Detection, rectification, and removal of poor quality and anomalous data
- Rectification of missing vessel attributes (e.g. dimensions, type of vessel)
- Machine learning enhanced categorization of unknown vessel types (e.g. vessels with no AIS ship type code)
- Verification and re-computation of dynamic data field as necessary (e.g. speed, coursing, turning rate)
- Spatial and temporal re-interpolation, coordinate system re-projection
- Machine learning enhanced detection and possible rectification of coarse tracks crossing over land through inland waterways
- Simplification and/or decimation of high-resolution tracks to reduce data size and preserve detail
- Verification of navigational status (e.g. fishing, anchored, moored, underway, grounded, etc.) through machine learning enhanced activity detection techniques
- General data enrichment and feature engineering

Once the AIS data has been quality controlled and refined to the best quality reasonably possible for modelling, key statistics are then extracted which will be used to parameterize the movements of vessels and drive their behavior.

### Model Generation

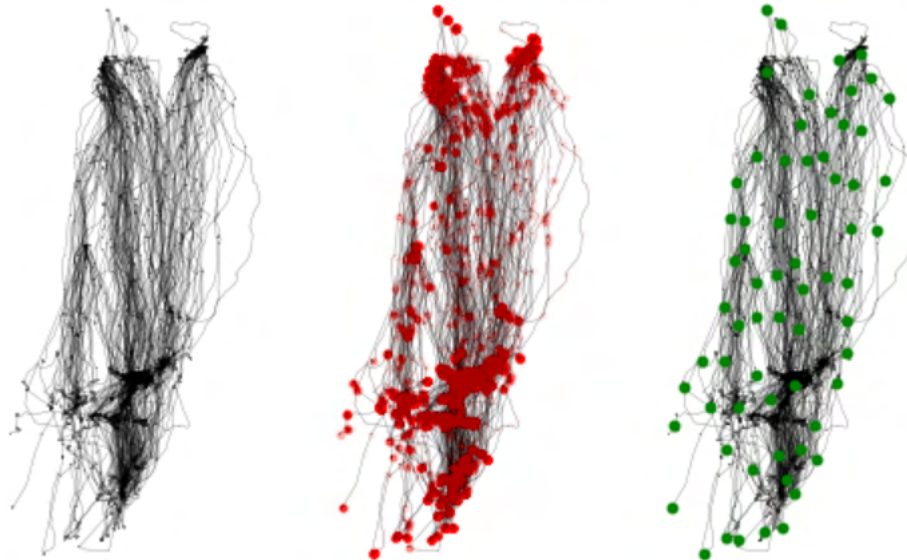
Using the pre-processed vessel tracks, a multi-step process is then completed to generate an unstructured graph representing the underlying traffic. First, the tracks are reduced down to their characteristic points; these consist of major changes in speed, direction, stops, and/or after a predefined constant spatial or temporal interval. This process is illustrated simply in the below figure.



**Figure K-1: Simplification of Raw AIS Tracks (left) to Characteristic Points (right)**

This is performed for all of the tracks in the dataset to make the data size more manageable while preserving the necessary level of detail, and to assist with further graph generation steps.

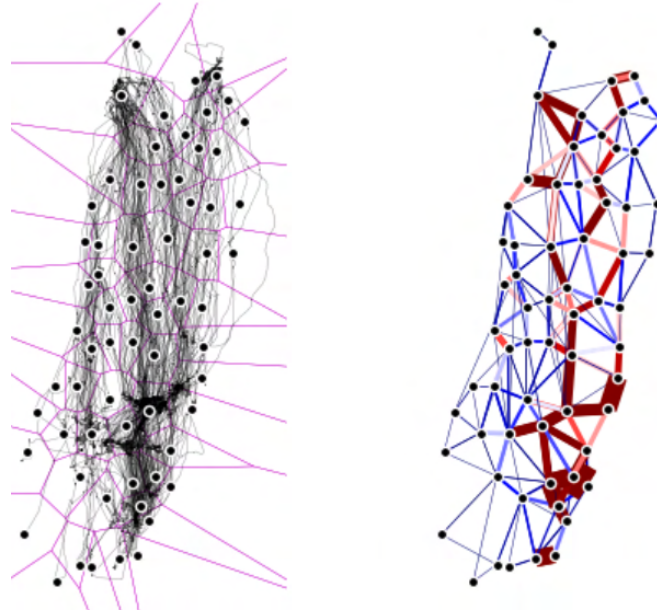
Next, the characteristic points of all of the tracks in the Study Area are considered together. An unsupervised machine learning technique (DBSCAN) is then used to generate an initial clustering of these centroids. This clustering is meant to group together nearby characteristic points with each other to define key locations in the traffic where changes (e.g. turns, accelerations, stops, straight sections) are occurring. The centroids of these clusters are then considered spatially representative of where these junctions are occurring in the traffic. This process is depicted simply in the figure below.



**Figure K-2: Extraction and Clustering of Characteristics Points - Raw AIS (left), Characteristic Points (middle), Cluster Centroids (right)**

Next, the cluster centroids are used to generate a Voronoi diagram, or a “mesh” of the underlying traffic junction points. The generation of a Voronoi diagram is the partitioning of a plane with  $N$  points into convex polygons such that each polygon contains exactly one point and every point in each polygon is closer to its edges than any other polygon. A Voronoi diagram is sometimes also known as a Dirichlet tessellation.

Finally, the raw AIS tracks are then routed through the Voronoi diagram, meaning the tracks are intersected with the cells to determine the chain of polygons that were passed through along the route. The result of this process is a chain of cells, which is then broken into segments, defining movements between cluster centroids or Voronoi cells. These segments are then used to count transits between centroids, and these segments and centroids are then used to form the nodes and edges of an unstructured graph of the traffic. The nodes of the graph are the cluster centroids, and the edges of the graph are segments that had at least one transit identified through the routing process. The Voronoi diagram and extracted unstructured graph representing the underlying traffic is depicted in the figure below.



**Figure K-3: Extraction of Representative Unstructured Graph of Vessel Traffic – Voronoi Diagram from Characteristic Point Cluster Centroids (left) and Routed Unstructured Graph (right)**

This process is repeated for all vessel types, or as necessary depending on the distinct and unique nature of traffic patterns in the AIS data. The outcome of this process is a representative graph of the traffic that is used as the basis of the navigational risk model execution. This process is automated but does allow for user intervention to finalize graph node locations for final routing. This ensures that fine, important, and local details are incorporated into the model, which can flexibly adapt to any model domain and can include adaptive resolution towards higher density areas.

Once the underlying traffic has been routed through the model graph, key statistics are then extracted from the model to drive the movements of the vessels in the SIREN model. This includes information such as:

- Statistics on start and end volume and frequency of tracks in at each node
- Statistics on vessel dimensions
- Speed distributions along graph edges
- Lateral offset distributions along graph edges

- Memory enhanced node-to-node routing probabilities
- Maneuvering behaviour and characteristics
- Mooring and/or anchoring locations and durations

Anchorage and mooring areas can be delineated from sources such as provided GIS files, international databases of port areas, or can be delineated programmatically from the AIS data itself.

From this graph generation and statistical data extraction process, a series of input files are created to be read by the SIREN model engine. These input files store the geometry of the graph, and all the inputs necessary to drive their movements in the ABM simulation.

#### Traffic Rules, Environmental Integration and Other Inputs

SIREN integrates a wide range of static, dynamic, and user defined inputs to realistically simulate vessel behavior and evaluate navigational risk under varying operational and environmental conditions. Among the most powerful features of the model is its ability to implement custom traffic rules and agent logic. These rules can be spatially defined and applied to specific vessel types or scenarios. Examples include slow-down zones, traffic separation schemes, and routing constraints, such as requiring tug escort support or modifying vessel speed and behavior when transiting through sensitive areas. In addition, custom operational logic can be embedded to reflect real-world practices, such as priority routing, restricted access during certain times or conditions, or rule-based behavior governing safe passage through narrow or congested waterways.

While it can incorporate environmental forcing from any formatted data source, SIREN is tightly integrated with the MIKE Powered by DHI modeling suite, enabling it to ingest and respond to high-resolution hydrodynamic datasets, including currents, wind fields, wave heights, tides, and visibility. Environmental thresholds (e.g., maximum safe wave height or minimum visibility for operations) can be defined, and the model will dynamically adjust vessel behavior, suspending, rerouting, or delaying operations accordingly.

Other environmental forcings, such as ice coverage, sediment dynamics, and bathymetric changes can be utilized as background forcings in the simulations to account for accurate real-world conditions. This flexibility allows the model to be applied beyond traditional traffic analysis to support broader environmental and operational planning. This background environmental forcing also provides the basis for the physics driven drifting and grounding calculation of vessels in simulations.

The model also supports the implementation of marine structures, both fixed and floating. These can include navigational aids, offshore terminals, mooring systems, FSRUs, or renewable energy platforms (e.g., offshore wind turbines). SIREN supports three-dimensional representation of structures, such as mooring lines, and can simulate how floating or drifting elements behave under environmental forcing.

In addition to data derived from AIS or other observational sources, SIREN allows users to define and inject synthetic data directly into the model. This includes the ability to manually modify the underlying traffic network, test “what-if” scenarios, or scale vessel activity in specific regions. Entirely new traffic layers can be introduced to simulate proposed vessel classes, such as future cruise ship operations. These synthetic traffic patterns can follow

predefined timetables, routes, or randomized behavior, and are particularly valuable when assessing the impact of future developments, infrastructure expansions, or modified operational regimes on navigational risk.

Together, these input mechanisms make SIREN a flexible, powerful, and customizable platform for simulating navigational risk under a wide range of scenarios, vessel behaviors, and environmental conditions.

### Model Execution

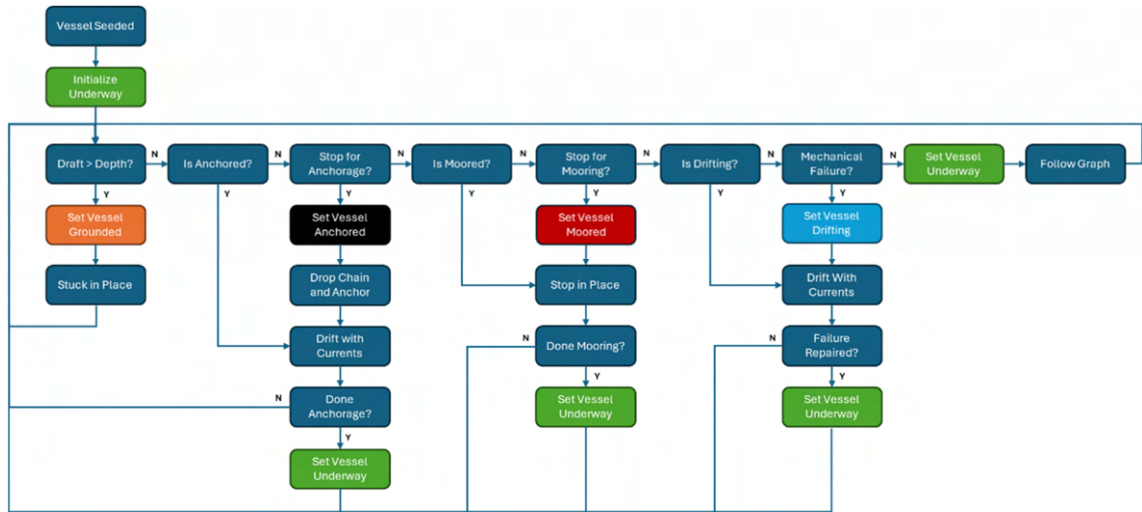
The SIREN model is executed in a Monte Carlo fashion, whereby a large number of simulations are run to approximate the underlying statistics of vessel traffic, and to avoid deterministic conclusions. For each simulation, the model engine steps through time for the defined study period (typically annual). As the model steps through time, vessels are seeded into the model domain according to the timings and statistics of the historical (or synthetic) data. From there, they enter a loop of decision making at each timestep to decide where they are going to go and at what speed and heading.

The decision-making logic driving the vessel movements is based a behavior model approach. In this approach, a series of distinct behaviors are defined for the agent in question, and the movements in each mode are parameterized from the underlying data. The SIREN model uses the following behavior modes:

- Underway: when a vessel is transiting (or maneuvering) under normal operational conditions
- Anchored: when a vessel is actively anchored
- Moored: when a vessel is actively moored (or stopped)
- Drifting: when a vessel has experienced mechanical failure and is drifting under environmental forcing
- Grounded: when a vessel's draft has exceeded water depth

The behavior patterns of underway, anchored and moored behavior modes are primarily driven by statistics extracted from the underlying data, as well as user defined custom logic or traffic rules. The behavior modes drifting and grounded are based on background environmental inputs.

At each timestep, vessels in the simulation are stepping through the decision process outlined in the logic diagram shown in the figure below. This is repeated until the end of the vessel's route, when the vessel is removed from the simulation.



**Figure K-4: Simplified Logic Diagram of Vessel Agents in SIREN Model for Each Behavior Mode**

Through time, these decisions accumulate into movements across the model domain closely approximating the input data and user defined rules or logic.

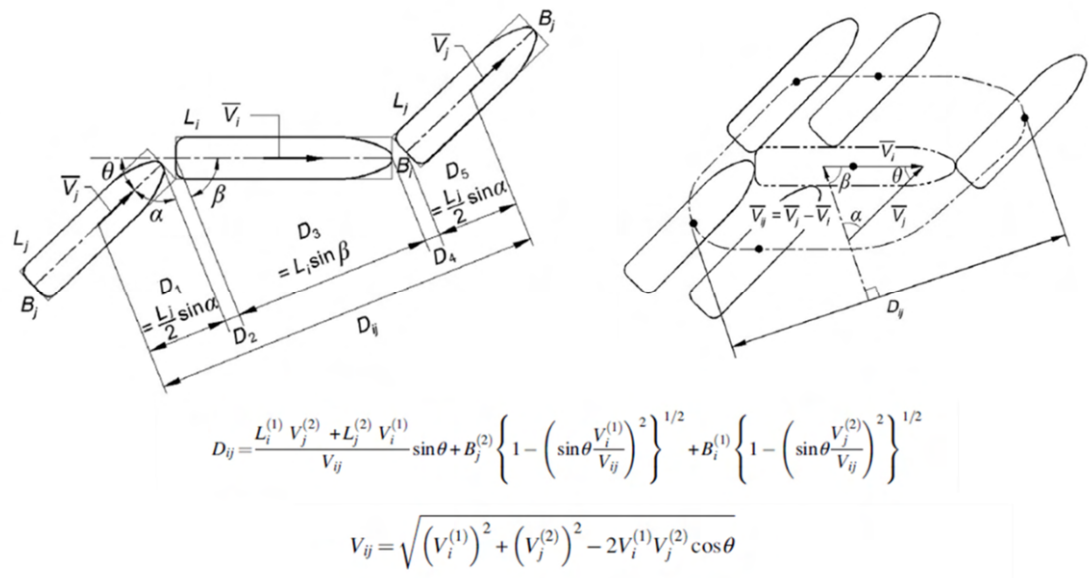
#### Risk Calculation

The final stage of the SIREN model involves the calculation of navigational risk, where simulated vessel behaviors and trajectories are analyzed to identify potential accidents, including collisions, allisions, and groundings. This is achieved through a combination of spatial detection algorithms, standard empirical methods, and probabilistic assessments, consistent with best practices in the literature.

At the core of the method is the collision diameter principle. Each vessel in the simulation is assigned a notional "collision diameter"— a dynamic buffer zone around its hull representing the space within which an encounter with another vessel or object may result in an accident. When two vessels pass close to one another and their collision diameters overlap, the model flags the interaction as a potential collision event.

Similarly, allisions are assessed by calculating when a vessel's collision diameter overlaps with the defined geometry of a structure or floating asset, such as a pier. Groundings are physically assessed as to when the hull of the vessel comes in contact with the bathymetry (accounting for both bathymetric levels and tides).

The collision diameter principle between a close encounter of two vessels is illustrated in the below figure.



**Figure K 5: Illustrative Example of Collision Diameter Principle During a Close Encounter Between Two Vessels (adapted from literature)**

Here, the i and j notation corresponds to the two distinct vessels, e.g. vessel i and vessel j. The constant L refers to the length of each vessel. The constant B refers to the beam (or width) of each vessel. The constant V corresponds to the speed of each vessel. And finally,  $\theta$  represents the relative angle between the two approaching vessels.

To evaluate these events, the model uses a Monte Carlo approach, in which many potential interactions are simulated over extended time periods. Each flagged encounter is logged in detail, storing information such as:

- Time and location of the event
- Vessel types and sizes involved
- Relative bearing and speed
- Whether either vessel was drifting or powered

This detailed record enables the model to evaluate not just whether a potential accident occurred, but how likely it was to result in an actual collision or allision. This likelihood is quantified using causation factors; empirically derived probabilities that reflect the chance of a potential encounter escalating into a real incident, depending on contextual factors.

Causation factors are applied to each potential event based on its recorded characteristics. A lookup table of causation factors, drawn from published literature and maritime safety studies, is used to assign the appropriate probability of accident occurrence. These probabilities are then used to generate final risk estimates for the simulation. The default causation factors for SIREN are listed in the below table.

**Table K-1: Default Causation Factors Used for Marine Accident Types in SIREN**

Accident Type	Causation Factor
Head-on	4.9 x 10 <sup>-5</sup>

Overtaking	1.1 x 10 <sup>-4</sup>
Crossing	1.29 x 10 <sup>-4</sup>
Grounding	1.59 x 10 <sup>-4</sup>
Allision	1.86 x 10 <sup>-4</sup>

### Post-Processing and Outputs

Once the simulations are complete, all potential and realized accidents are aggregated and categorized. Outputs are broken down by:

- Accident type (collision, allision, grounding)
- Vessel status (powered or drifting)
- Vessel type (cargo, passenger, tug, etc.)
- Time of occurrence (hour of day, season, operational window)
- Geographic location

These results are used to calculate accident frequencies, which are reported as the expected number of incidents per unit time (e.g., per year) under the simulated conditions. The model also generates a suite of visual outputs, including spatial density heatmaps, risk contours, and summary statistics tables. These outputs provide rich spatial and temporal insight into where and when the risk is greatest, and which vessel types or operational factors contribute most significantly to that risk.

Together, these findings form the basis for interpreting the navigational risk in the Study Area and are used to support the development and evaluation of mitigation strategies which can further be evaluated through additional SIREN model runs.